

DOCUMENT RESUME

ED 065 338

SE 014 403

AUTHOR Swanson, Mary T.; Taylor, June
TITLE Educational Multi-Media for Mathematics and Science Tutors.
INSTITUTION Des Moines Area Community Coll., Ankeny, Iowa.
PUB DATE Feb 72
NOTE 217p.
EDRS PRICE MF-\$0.65 HC-\$9.87
DESCRIPTORS Activities; *Audiovisual Aids; *Elementary School Mathematics; *Elementary School Science; Handicapped Students; Instruction; Instructional Materials; *Instructional Media; Learning Activities; *Tutoring

ABSTRACT

In the belief that uses of many different media will help motivate students, this book was compiled to assist tutors, particularly in science and mathematics, in using multi-media. Special emphasis was placed on increasing the tutor's understanding of mathematics and science. Following a chapter on the history and development of instructional technology, classroom media equipment (such as films, filmstrips, transparencies, pictures, tapes, etc.) is described with its advantages and disadvantages and instructions on determining appropriate usage. Some simple techniques for using media are outlined, including uses for easily obtained household items. Two chapters cover some elementary mathematics and science concepts and the applications of media to tutoring in these areas. A section on the handicapped child and adaptation of media to his situation is also included. The final chapter comments on the tutor's role, and sources of free and inexpensive materials are listed with the bibliographies. While the subject matter is generally from the elementary level, the discussions about the media are intended for all levels. (JM)

ED 065338

SCOPE OF INTEREST NOTICE

The ERIC Facility has assigned this document for processing to:

SE

EM

In our judgement, this document is also of interest to the clearinghouses noted to the right. Indexing should reflect their special points of view.

U.S. DEPARTMENT OF HEALTH,
EDUCATION & WELFARE
OFFICE OF EDUCATION
THIS DOCUMENT HAS BEEN REPRODUCED EXACTLY AS RECEIVED FROM THE PERSON OR ORGANIZATION ORIGINATING IT. POINTS OF VIEW OR OPINIONS STATED DO NOT NECESSARILY REPRESENT OFFICIAL OFFICE OF EDUCATION POSITION OR POLICY.

NCIES

Educational Multi-Media for Mathematics and Science Tutors



**Project MOTIVATE
des moines area
community college**

**Educational Multi-Media
for Mathematics
and Science Tutors**

by

Mary T. Swanson

June Taylor



Project MOTIVATE

**PROJECT DIRECTOR
Dr. Philip D. Langerman**

In cooperation with the U.S. Office of Education
as authorized by Education Professions
Development Act.

FEBRUARY 1972

**des moines area
community college**

2006 ANKENY BLVD., ANKENY IOWA 50021

INDEX

	Page	
ACKNOWLEDGEMENTS		
INTRODUCTION		
Chapter One	HISTORY AND DEVELOPMENT OF INSTRUCTIONAL TECHNOLOGY	1
Chapter Two	CLASSROOM MEDIA EQUIPMENT	7
Chapter Three	SIMPLIFIED MEDIA TECHNIQUES	55
Chapter Four	APPLICATION OF MEDIA TO MATH TUTORING	71
Chapter Five	APPLICATION OF MEDIA TO SCIENCE TUTORING	115
Chapter Six	VISUAL, AUDIO AND TACTILE MATERIALS FOR HANDICAPPED CHILDREN	154
Chapter Seven	THE TUTOR'S ROLE	178
	BIBLIOGRAPHY	200

ACKNOWLEDGEMENTS

We wish to express appreciation to those who contributed materials and counseling to aid in the preparation of this book:

Jo Barnes, Director, Des Moines School Volunteer Program

Winifred Beardsley, Teacher and Consultant for the Visually Handicapped, Des Moines Public Schools

Dr. Marvin S. Davis, Director, Regional Area XI Media Center, Des Moines, Iowa

Sarah A. Davis, Director, Volunteer and Tutorial Program, Los Angeles City Unified School District

Rolfe B. Karlsson, Executive Director, Camp Sunnyside, Des Moines, Iowa

Don Kurth, Hearing Consultant for the Polk County and Des Moines Schools

Ed Mann, Media Specialist, Des Moines Area Community College

Clarice Plager, former West Des Moines Science Teacher

Mrs. Betty Ronat, Science Instructor, Des Moines Area Community College

Gary Wilcox, Mathematics Instructor, Des Moines Area Community College

Dr. Richard Winter, Consultant for Emotionally Disturbed and Visually and Physically Handicapped, Pupil Personnel Services Branch, Division of Special Education, Iowa State Department of Public Instruction

INTRODUCTION

In 1918, the United States Office of Education stated that to understand the "life" of our society, we must establish goals to develop the idea that a person contributes something to our society, that a person needs to develop a vocation and know how to exist on his salary, and that people should be helped to realize their own potential as an individual.

To realize these goals, we must not rely so much on books, but must utilize the things in our communities that are resources for learning, right around us in every day life. Youngsters want to explore things, to be physically and mentally active and to be able to express themselves. To allow students to touch, hear, see, smell and taste, and to learn, multi media must be applied to the classroom situation.

At the Right to Read Workshop in Washington, D.C., March 30-31, 1970, Dr. Don Davies, now Deputy Commissioner for Development, U.S. Office of Education, said, "There is an important place for volunteers in schools--- for all kinds of volunteers---teenagers working with other youngsters, college students, middle class housewives, businessmen, people from disadvantaged communities working in the schools that serve those communities, retired people, people who are paid for their volunteer services, people who are not paid, people of all colors, people with all kinds of background. There is a place for all these kinds of people in volunteer programs if they are properly organized."

He further stated "---that the child's senses are bombarded by exciting new media constantly, almost from the time of birth. The child finds libraries and schools and conventional educational settings and activities sometimes dull and lifeless compared to the vitalities of the moon shots, professional football, or 'Sesame Street'. This is a very good point. I think it is true. I think some of our conventional educational approaches are in fact dull and lifeless.

"This is one of the reasons why we constantly talk about motivation of children. We want them to go to schools, want them to do the things we think are necessary for them to do. We do not talk about motivation at all. We have all seen youngsters with their portable radios listening endlessly to the Beatles without any teacher or tutor or volunteer motivating them. Now it seems to me there is a good deal to be learned from that. We need as educators and/or as volunteers to harness technology for our own purposes and to exploit that part of the life of the child which comes to him through the media. We need to use the machines of technology to enliven, enrich and make more powerful the work that we do with children. We need to harness the machine and harness technology for our own purposes rather than to assume, as humanists, the machine is our enemy, and that the humanizing aspect education will be destroyed by technology. I maintain that technology, properly utilized, can play a real part in humanizing education."

This book has been compiled to assist volunteers and instructors of volunteers in the educational setting to become knowledgeable about the advantages and techniques of using multi media in the educational setting, with particular emphasis on the preparation of materials for use in tutoring in the areas of mathematics and science.

An introduction to media, including history, and information about the copyright law provides the basic concept as to the value of visual aides.

So that a volunteer may be better trained to assist teachers in the operation of classroom media equipment and to utilize simplified media techniques, diagrams and instructions have been prepared. Special emphasis has been given to provide an understanding of mathematics and science, so the volunteer may prepare materials useful to enrich and tutor the child in these subjects.

Because handicapped children, in particular, need additional tangible educational tools, one chapter has been developed in this area.

Dr. Davies also said "---that participation and involvement of teachers, and of the community, and of the parents, as well as other interested parties, are essential keys to the success of any such program." To accomplish this, staff-volunteer relationships and job descriptions have been defined as suggested guidelines, to be adapted to each local and state situation. Because laws vary greatly in different states, each of these recommendations should be carefully explored as to what the role, responsibility and rights of volunteers may be in each locality.

CHAPTER ONE

HISTORY AND DEVELOPMENT OF INSTRUCTIONAL TECHNOLOGY

COMMUNICATIONS REVOLUTION

The influence of the mass media on students can hardly be estimated and certainly surpasses the influence of the schools. Media is probably best defined as the instruments or means of communication. The mass media, - books, newspapers, periodicals, radio and especially television are quite familiar and have made today's young people better informed and involved in the world and its problems than any other generation. Media encourages fads such as clothing, hair styles and slang to sweep the country. Media encourages the young to travel from coast to coast to participate in festivals or demonstrations. Media unites the young in movements to rectify what they believe to be injustices.

While the young are united by the mass media, the elders cling to their own ways, making only feeble attempts to understand either the young or the impact of the mass media.

As the influence of the mass media has grown, the influence of the schools has waned. It has been estimated that by the time most students graduate from high school they have watched 15,000 hours of television and have seen 500 feature length motion pictures and spent 11,000 hours in the classroom.

The standard teaching method has involved the teacher making a reading assignment, then talking, lecturing or perhaps questioning students on the reading assignment. This activity is usually followed by a teacher-made test. This traditional method keeps all students in a class working and learning at the same pace, and making little allowance for individual differences. Educational technology, by using educational media, can individualize learning for every student.

Educational media can be defined as the instruments of communication used in instructional settings. Books, chalkboards, films, records, tapes, slides, still pictures, etc., are all media used in the classroom.

HISTORY

Good teachers have probably used the instructional materials available to them since pre-historic man brought pieces of flint or obsidian into the cave to show his sons the proper way to form the tip of a spear.

Comenius's search for better methods of teaching led him to develop a picture textbook called Orbus Pictus. This early example of teacher produced instructional material was first published in Nuremberg in 1658. It was still being purchased as late as 1810 in the United States!

Present day instructional technology had its beginnings about the turn of the century in part due to the beginnings of using a scientific approach to solving educational problems and because of the invention of such things as the motion picture and recording devices.

Various approaches were made toward developing a technology for education. Progress was made slowly until World War II. The demands made on industry and the military to train millions of people in new skills led to the development of many audio-visual methods which has led directly to our modern instructional technology. The establishment of educational radio, the development of television and other electronic marvels have added to our modern instructional technology which holds so much promise for education.

A series of legislation passed by the Congress in the last decade or so has made funds available to purchase necessary material and equipment and also provided funds for training programs. It has been a long path from the first attempts in Davenport, Iowa (1878) to organize an instructional resource center which was a type of cooperative instructional museum to our modern Media Center. Many improvements are still to be made.

VALUE OF VISUAL AIDES

Modern educational media puts few limits on the educational experiences available in the school. It is possible to bring the world inside the classroom and visit the most remote corner of the earth or examine even microscopic organisms in great detail. Through media, each of us can cross the expanse that is space and walk upon the moon, visit Ancient Athens at its zenith, peer over the shoulder of Jefferson writing the Declaration of Independence, even crawl inside the heart to see the working of the valves.

Media allows us to participate in learning experiences that otherwise are too costly, time consuming or dangerous to be practical in a classroom. With media we can be exposed in a few minutes to the happenings of the past or those that occur over a period of time. There is almost no limit to the learning experiences students can have with media.

Media has the ability to provide all students with a common background for learning. Media provides useful information to everyone. A mediated lesson will lead to a variety of additional learning activities. An excellent way of overcoming physical and financial limitations is provided with use of media. Students, given the opportunity to participate in the planning and preparation of materials for a media presentation, often become deeply involved with the subject.

Education has existed very nicely all this time with a minimum of media. Why should more be needed now?

1. We have more students with a wider range of ability and background than ever before. We are no longer willing to ignore and discard students who do not fit the academic ideal.
2. The curriculum is changing rapidly because of the explosive growth of information. It has been estimated that there is one hundred times more to know now than in 1900, and that accumulated knowledge doubles about every ten years.
3. Students come to school versed in very sophisticated communications and are disappointed when they find the schools are not.

The large amount of commercial media materials available covers almost every subject of widespread interest. Perhaps this is their weakness, because to be profitable they must appeal to a wide audience and fit many teaching styles. The research, preparation and distribution time for these materials do not allow coverage of current topics.

Locally prepared instructional materials, on the other hand, may not be able to cover the remotest reaches of the earth, nor would they necessarily appeal to widespread use. They can, however, cover events as current as this morning's newspaper. Materials of local interest, that would not be profitable for a commercial producer, can be developed. Best of all, locally produced materials can be tailored to fit a particular teaching method.

The use of locally produced materials is perhaps more varied than the materials themselves. Moldstad and Faris¹ believe that teachers can use locally produced materials for (1) instruction in the regular classroom, (2) for instruction to large groups, and (3) for instructional television. Students can use material they have produced to solve various problems in communication (1) for science fair exhibits, (2) to illustrate the year book, (3) for posters to announce school events, (4) for classroom reports, and (5) for reports submitted to the instructor. School administrators can use locally produced media to present information (1) to school board and other school volunteer advisory committees; (2) to the public, such as Parent Teacher Associations and other citizen groups; (3) to school faculties at teachers meetings, workshops, seminars, in-service training programs, and (4) to volunteers for orientation and training.

¹John Moldstad, Gene Fair, "Local Production Programs Serve....," Audiovisual Instruction, VIII (May, 1963), p. 292, 293.

COPYRIGHT LAW

When producing local materials, we should all be aware of the copyright law. Because it was written some years ago, before modern technology, there has been some confusion. The schools tend to operate under the doctrine of fair-use which states: "In some circumstances where the use is reasonable and not harmful to the copyright owner's rights, copyrighted materials may be used to a limited extent without obtaining permission." This doctrine primarily applies to education and educational research although it is not limited to these.

It is necessary to understand the doctrine of fair-use, for without it we would be without many of the teaching materials that are used in our classes.

Our present copyright law is extremely hazy and there is very little agreement as to exactly what it means. It would be best to consult a lawyer, however, if we can answer "no" to the following questions, we will probably be on safe grounds if any publisher or educational material producer would wish to take us to court. The questions are as follows:

1. Would copying a chart, articles, book, etc., deprive somebody of his just profits, and
2. Would copying information be an attempt to save the institution money?

Even though the answers to these two questions are 'no', we might still be breaking the law in specific circumstances. Each instance must be decided by the court on its own specific merits.

On the basis of past rulings from the courts, we can make certain educated guesses as to what is allowable and what is not.

1. A teacher may make a transparency or chart, and if used in his classroom, it is considered legal. However, if the teacher's supervisor were to see a chart and make a copy of it and send it to the teacher for use in his classroom, this is considered to be illegal.
2. Taking the case where the teacher does prepare a transparency of the chart, he is not supposed to file the transparency among his lesson plans for future references. This type of activity could become an infringement because it might be argued that over a period of time he will copy other parts of the same works and hence, accumulate the major portion of that work.
3. Diagrams, charts, pictures, etc., from copyrighted works may be reproduced for distribution to a class. However, if the teacher were to ask the students to retain the information in their notebooks and study it for future reference, this may be illegal. There have been instances where courts have decided that fair-use

requires that all copies must be recalled and destroyed after temporary use. It should be noted here that we are talking about single pages and not copying large sections of a copyrighted work in order to save students or the institution money by not having to buy the book.

4. It is generally interpreted that multiple copies should be limited to the size of a class and that circulation should be limited to a single classroom. This would mean that if a science teacher found something that he wished to copy for his students, he should not make enough copies for all the science students in the institution.
5. Television programs are generally copyrighted and the above statements apply to them also. This would mean that it is definitely illegal to copy whole programs, but specific parts could be copied by video tape and played back for a class discussion with the tape being erased after the class has used it.

If in doubt, volunteers should check with the building principal or the classroom teacher for whom they are preparing media.



CHAPTER TWO

CLASSROOM MEDIA EQUIPMENT

The first motion picture film was made in 1894, but it was not until World War II that they proved their full value for educational purposes. In 1958, the launching of Sputnik resulted in the National Defense Educational Act, which provided funds to build libraries and furnish classroom media equipment, with emphasis on science and mathematics materials. The Elementary Secondary Education Act of the 1960's provided additional funds for films, libraries and special educational purposes.

At a ten day meeting called by the National Academy of Sciences in 1959, there was considerable discussion of the devices and apparatus of teaching that may be used in instruction. Some devices are designed to present material to students of a kind that would not be available to them in ordinary school experiences. Jerome S. Bruner¹ lists films, TV, micro-photographic film, film strips, sound recordings, books and the like as tools by which the student is given vicarious though "direct" experience of events. Since the enrichment provided is one of the principal objectives of education, he calls these "devices for vicarious experience". He categorizes devices as model, dramatizing and automatizing.

Just as devices can supplement and assist the teacher, so can a volunteer, who in operating a machine or preparing materials, can add another pair of hands, eyes and ears to the classroom. Proper instruction and supervision by the teacher will provide an enthusiastic and knowledgeable volunteer. During the 1960's, experience indicated that the key to learning is individualization, and services from a volunteer is one way to increase this individualization. All ages of persons, ranging from elementary, secondary and college students to senior citizens may contribute constructively to educational multi-media programs.

The following information is presented to enable a volunteer to have fundamental knowledge and convenient instructions to understand and operate classroom media equipment.

PROJECTORS

FILMS

Students may be trained with films for visual literacy, to see as well as read. Often they look but don't see. Teachers can find films for use in their classrooms on almost any subject, sometimes for an entire course in a particular subject. Eight millimeter films with sound are newer than 16 millimeter, and can be produced by teachers and students, or may be purchased commercially. Film strips are good media when motion is not essential.

¹Jerome S. Bruner, "The Process of Education", Harvard University Press, Page 81

There are several kinds of educational films available:

1. Factual film for information
2. Pictorial reports
3. Fictional drama (i.e., Hamlet)
4. True drama (story of Pilgrims)
5. Travelogue
6. Training
7. Documentary

Utilization of films may be for -

single concept
skill illustration
performance record
problem situation
research
record of events
local community participation
public relations



MOTION PICTURE

Advantages of motion pictures are -

meanings involving motion can be presented
past or present times can be shown
realism can be added to lesson
unique process and objects through specialized photography
attitude change influenced
few physical limitations
students with reading problems learn from film
film provides common experience
lesson can be open ended
skills can be learned from film
everyone has a front seat
entire film does not have to be used

To obtain films, write to the United States government or to distributors, or contact a media center or librarians at the school. Films can be misused and become entertainment, instead of learning. There is no educational advantage to color film, if color is not essential to the presentation of the subject. As students get more used to learning from films, they will learn more and more, and there is a proper time in the lesson schedule to show films. A repeat showing may help a student, particularly in learning a skill. Films may be shown for a maximum of one hour, depending upon age, but in a whole series of films, an hour a day for months may backfire and no longer reach or interest the students.

Before using a film, it should always be previewed by the person who will be discussing it with the children, to observe and plan to -

discuss general topic of film, and how it relates to subject, to prepare children
determine students' knowledge of subject
discuss new vocabulary or terminology in film

ask different students to watch for different things in the film
explain special photographic techniques, such as time lapses
allow students to participate in showing
be flexible and ready to discuss current and topical ideas of interest,
as they arise
use follow up, through a quiz, discussion, creating materials, bulletin
board display, essay or term paper, or inviting a resource volunteer
to implement presentation.

Notes should not be taken during initial screening of film, but a few may be
jotted down afterwards; film may be stopped at intervals for questions or
note taking.

In planning for use of film, volunteer may assist teacher to -

- identify learning problem
- select appropriate film
- order early
- preview film, and read film guide, if available
- make notes for question and answer period, or quiz
- schedule equipment
- set up equipment before class begins
- use film when related to unit of study
- relate subject to other materials available, such as reference books,
pictures, specimens, publications, models and realia.

To instruct volunteers and others to operate projection equipment in your
school, a diagram of each type of projector should be made and given to them,
or be available in the classroom. Diagrams of two 16 mm projectors
(Figures 1 and 2) are illustrated, and overlay masters may be made from
these for distribution in training sessions. Because 8 mm projectors vary
greatly in detail, each school should provide a diagram of operation of the
equipment, which usually is in the instruction booklet. To make a presenta-
tion, thread film correctly, with sound track on inside and sprocket holes
toward you. Test to see if film is synchronized, in focus and if sound is
at a good level. Rewind to where title starts and turn off machine until
ready for viewing. After film has been shown, turn lamp off and let fan run
to cool machine.

Film is projected by means of a lamp for light, condenser lens to concentrate
light to a beam, shutter, aperture, the film which goes through upside down,
lens, and the image on the screen.

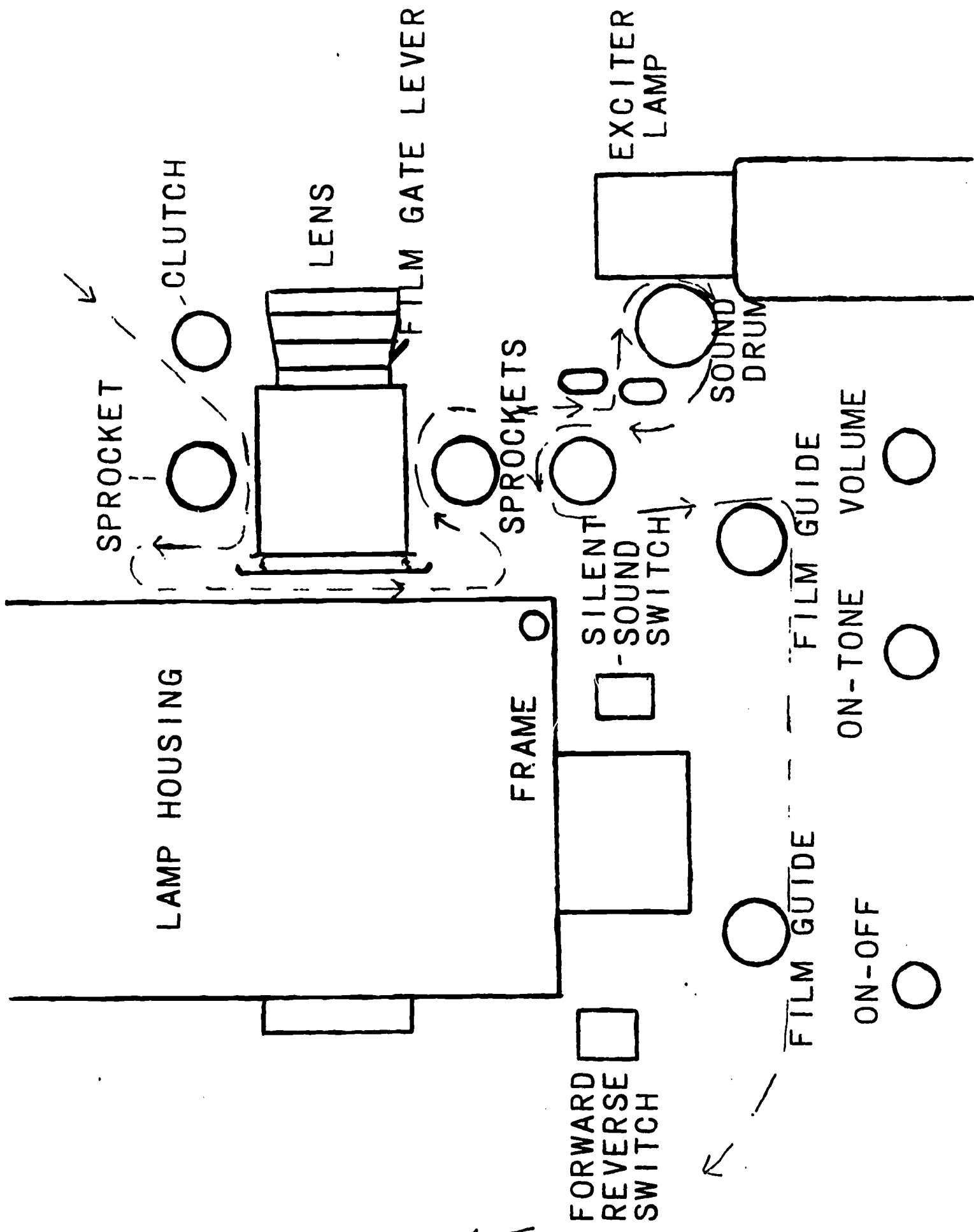

BELL & HOWELL 16 MM PROJECTOR

Figure 1

-11-
16/17

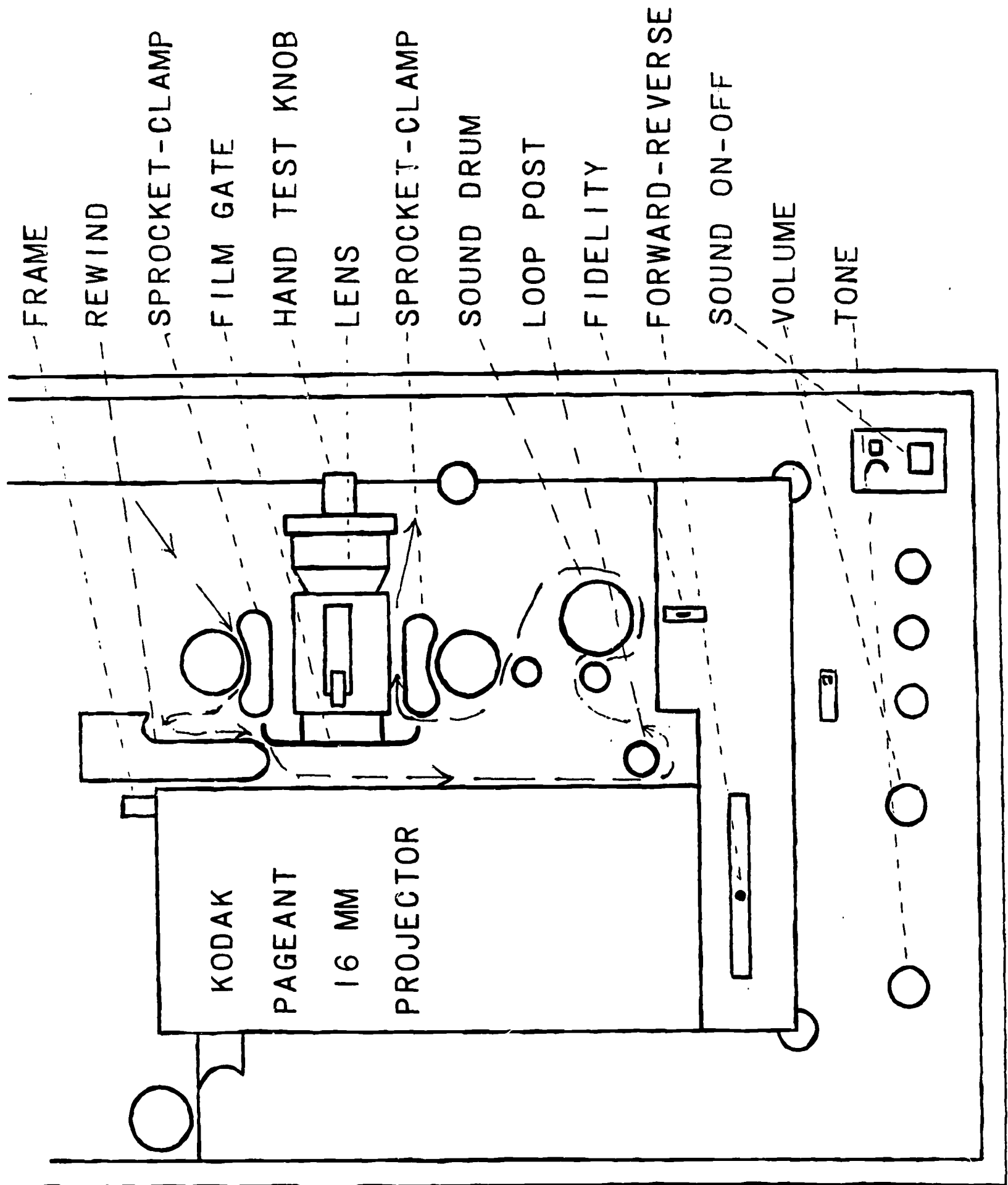

Figure 2

STILL PROJECTION

FILM STRIPS

The cost of film strips average from \$12 to \$20; some are superb and some are really terrible. Quantities of film strips can be purchased on any one subject, and they are best used when combined with other media. The picture should be of good quality if learning is to take place, and often too many details are put on one film. Filmstrip projectors (Figure 3) are easily operated by adults or students. Film strips are useful for -

- understanding symbols
- teaching "how-to-do" skills
- providing information and factual data
- art exhibits
- introduction or summary of a unit
- supplemental information for other materials
- individualized instruction, under direction of teacher; assisted by volunteers (not same as self instruction)

In choosing film strips, to be sure it is really applicable, determine -

- is it accurate?
- is it up to date?
- does subject lend itself well to film strips?
- is it on the right level for student?
- is it technically well done?
- can captions be read well?
- do captions explain picture?
- is color good?
- does it get educational message across?
- is it passive?
- can students participate or will they just sit and look?

• The advantages of film strips are -

- show planned sequence of ideas
- encourage discussion
- permit pacing of material
- availability in many subjects
- inexpensive and easily stored



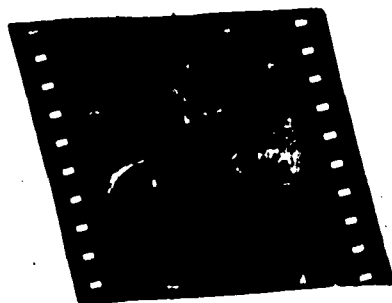

GRAFLEX FILMSTRIP PROJECTOR

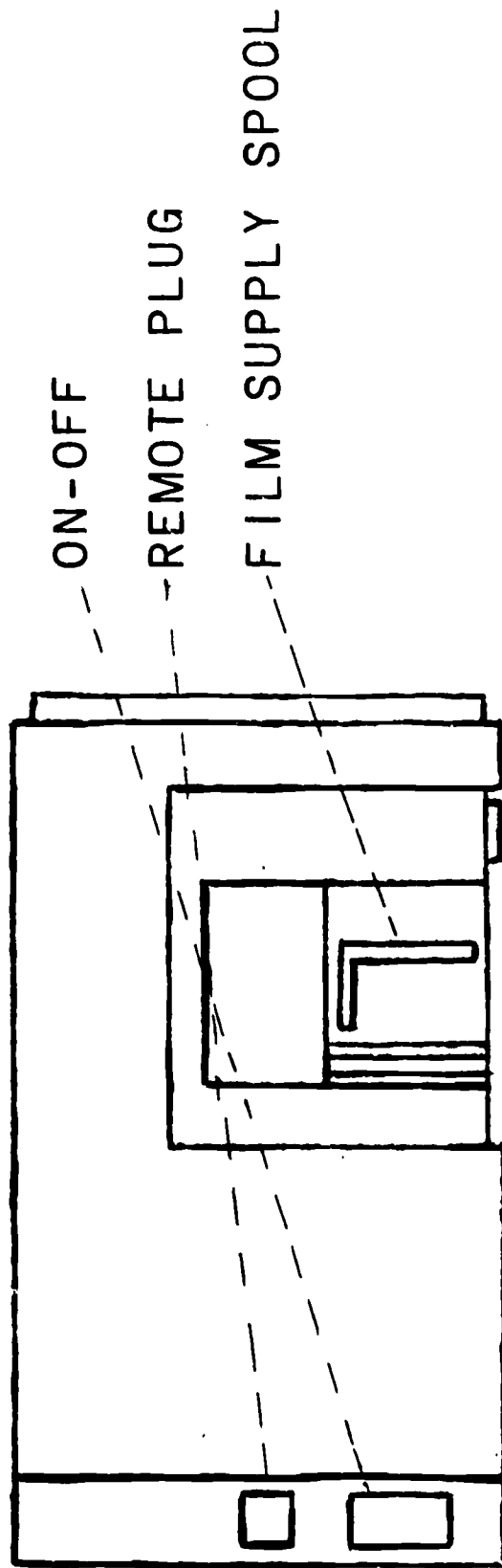
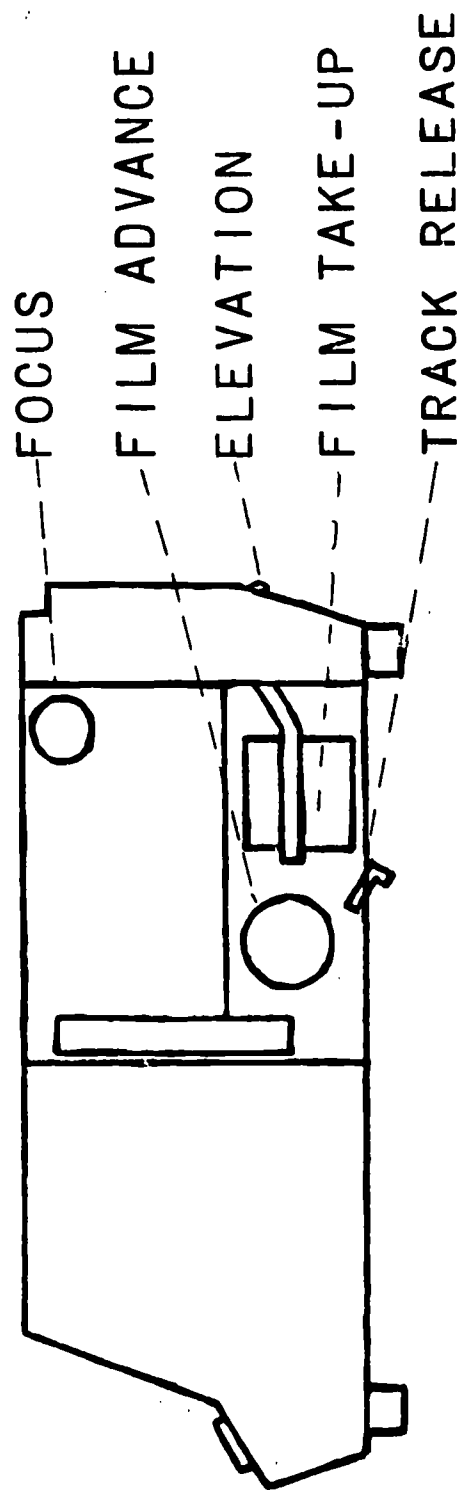

-17- / 18
21

Figure 3

SLIDE PROJECTOR

Slides are available on many subjects, and children may have their own from trips or may take slides during a project or on a field trip. Resource volunteers may have many sets of slides from trips, hobbies or special projects in which they are involved, and often are most willing to show these to classes. One of the easiest slide projectors (Figure 4) to operate is the Kodak Carousel. Slides are inserted in the holder, upside down, beginning with #1 and progressing numerically. A small ring turns to lock or remove the slides.

Slides may be made from library books and other resources, and thus permanently kept for classes, and are particularly useful to present reproductions of art, drama, history and current events. Care should be exercised concerning the copyright law. Advantages to slides are -

- easy to produce locally
- made to specific needs
- can be arranged in any order, and revised
- easy to revise and update presentation
- combine effectively with taped narration
- inexpensively produced

FILM LOOP PROJECTOR

Cassette films, or film loops up to 5 minutes in time, are available, often with a separately printed text and wide variety of titles. The projector (Figure 5) is lightweight, small, very portable, and easy to operate. Cassette films with sound are also available. In comparison to 16 mm films, cassette films are relatively inexpensive. They may be obtained in series in certain subjects and particularly in many areas of science.

KODAK CAROUSEL SLIDE PROJECTOR

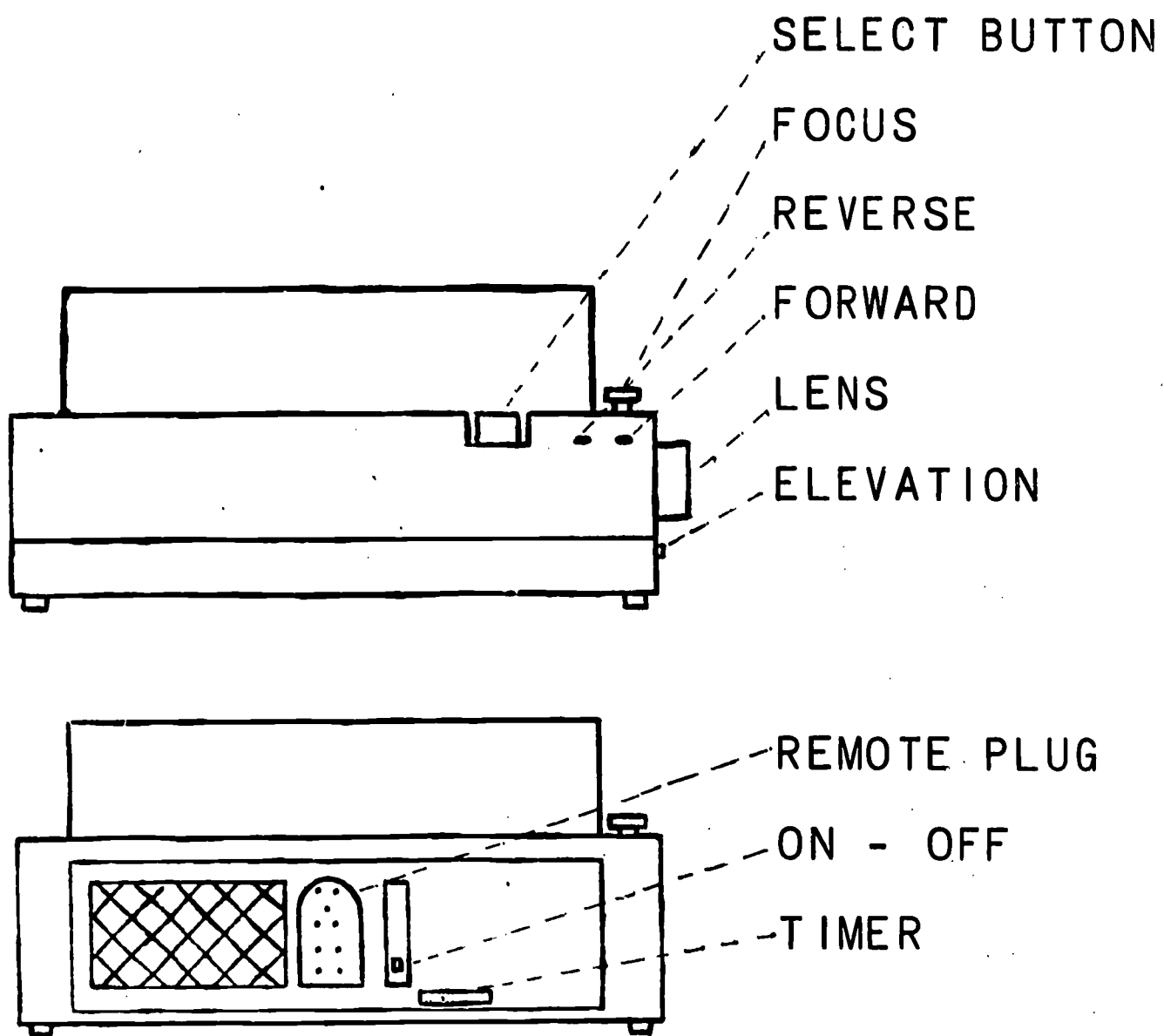

TECHNICOLOR 8 MM FILM LOOP PROJECTOR

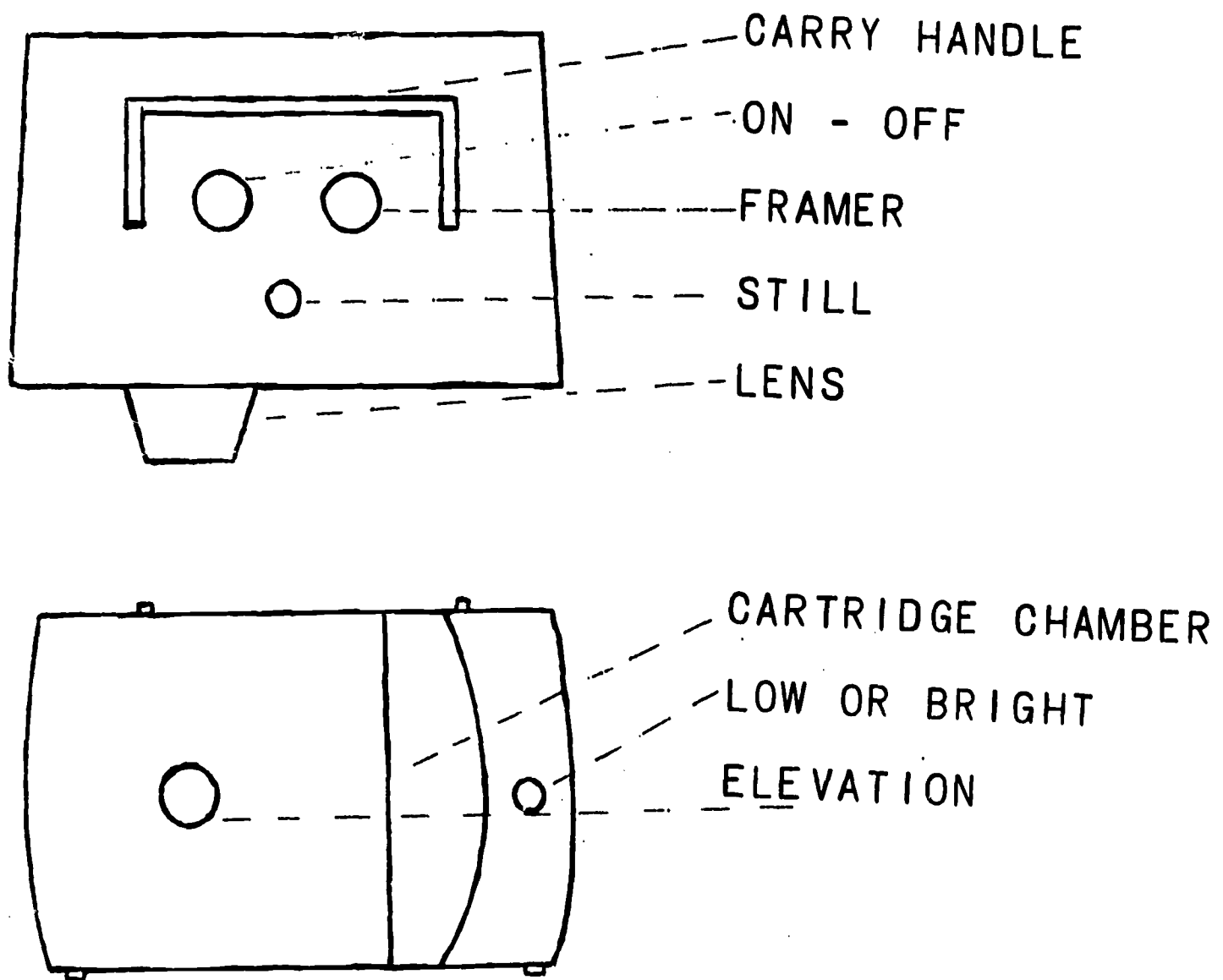

-23- / 24
24

Figure 5

TELEVISION

Through the combination of motion pictures and the best of television programs, a well planned course may materialize. With the availability of a television set, economical and easy lessons may be planned. The three categories of television are commercial, educational, and instructional, which may be closed circuit or video tape. Television can bring about mass social changes and easily capitalize on the here and now. Reasons why instructional television has not been very successful is that the quality of instruction usually has been very poor and classroom use has not been effectively presented. The teacher must prepare herself in advance through guides available. Too often the same old show is repeated. Television has been most successful in grades 3 through 9. The role of the volunteer is most valuable, in the resources added to programs and through utilization of other media combined with television programs.

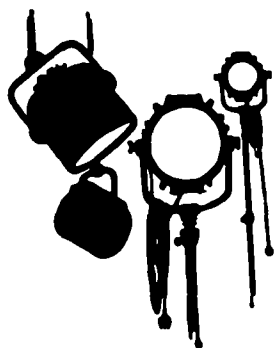

OPAQUE PROJECTOR

Many materials may be projected with an opaque projector, as it is the only machine that does not have to have light go through the material to project the image. The result is produced with mirrors. Any pictures, from magazines, text books, or other printed resources may be projected on a screen, and without removing the material from the bound copy.

OVERHEAD PROJECTOR

An overhead projector presents much flexibility for presentations and the following advantages for the instructor, who can -

- face the class
- see transparency while speaking
- write on transparency for illustration
- leave lights on for note taking

There is a wide variety of transparencies available to purchase, but they should be carefully examined, as some are not very usable. Teachers and volunteers easily can make them for specific uses, in a short period of time. Figure 6 illustrates the way that people "read" pictures.

TRANSPARENCY

PEOPLE LOOK AT PICTURES IN THE FOLLOWING WAY

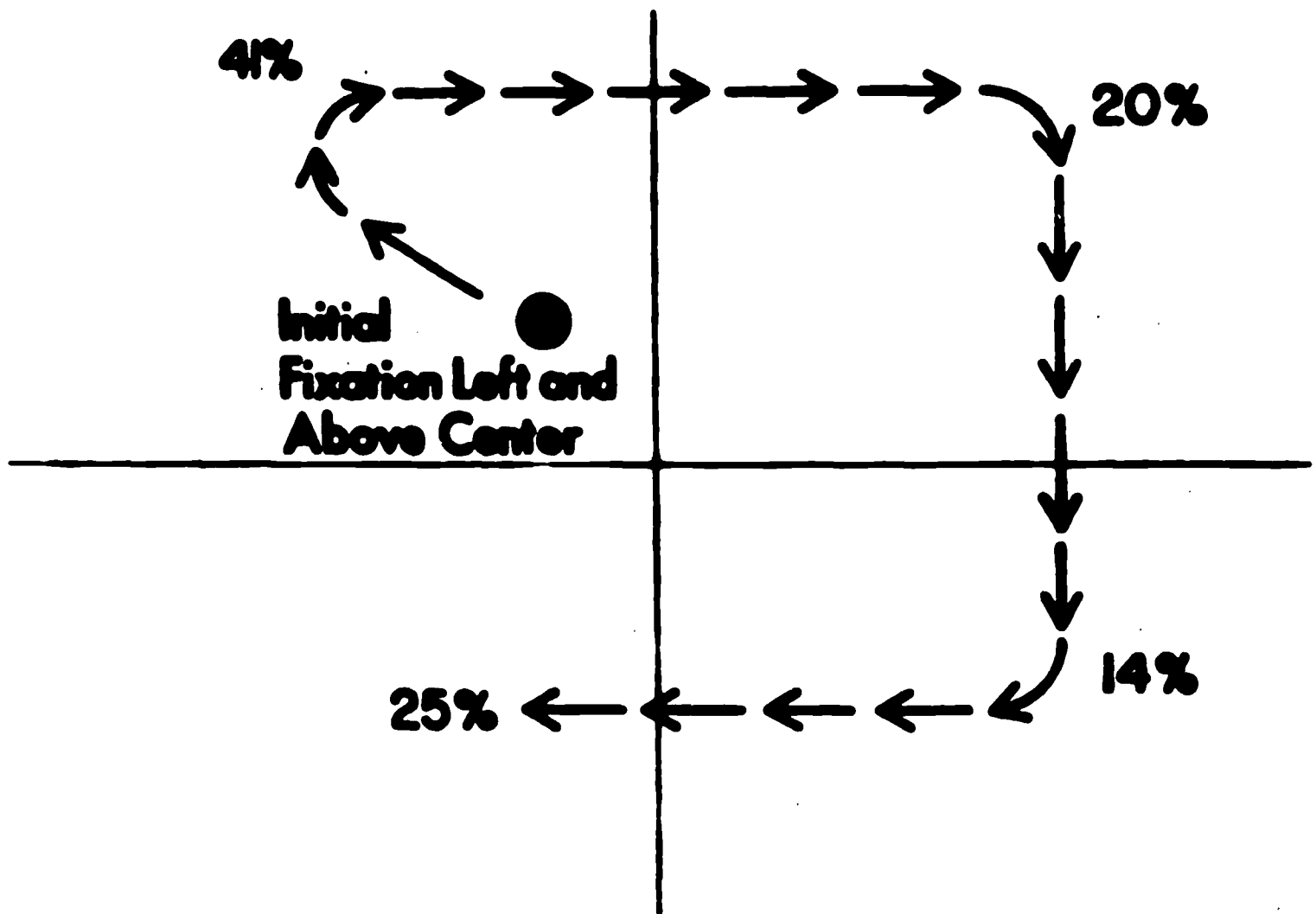

TRANSPARENCIES

As with any learning aid the usefulness of the transparency, from the learner's standpoint, is determined by its effectiveness.

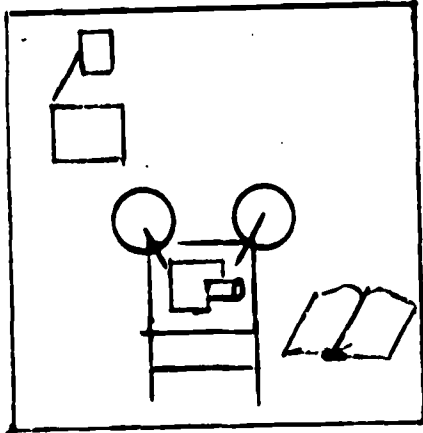

PLAN

Part of planning involves the selection of the proper medium for transporting the idea. Transparencies are best used for visual observation or reinforcement. If the completed visual contains a large amount of verbal material then another medium should be considered.

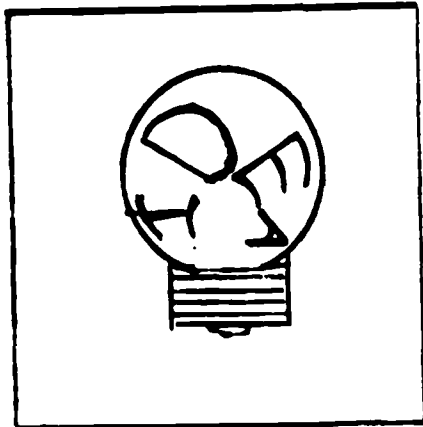

Zero in on a specified concept so that it is meaningful.

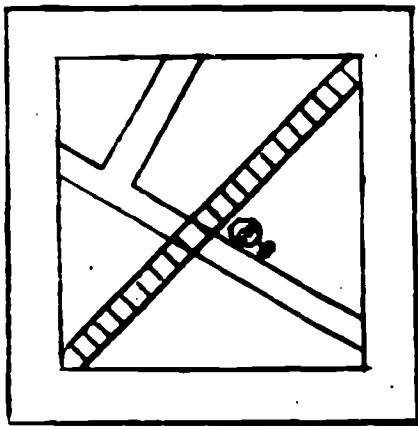

Keep it simple. Too much detail or information may detract from the learning situations. In general, limit each transparency to one concept.

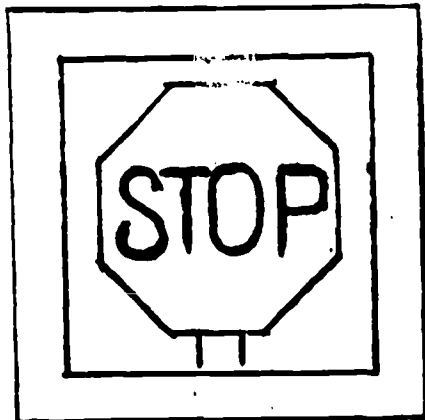

Letter not less than $\frac{3}{16}$ inch. Assume in the planning the learner in the back of the room has a seeing problem.

If color is used, have a specific purpose in mind -- accent, variety, contrast, separation, etc.

DESIGN

The visual appeal of the transparency may effect its usefulness as a learning aid.

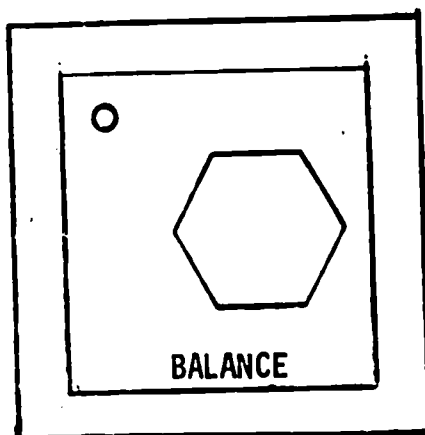
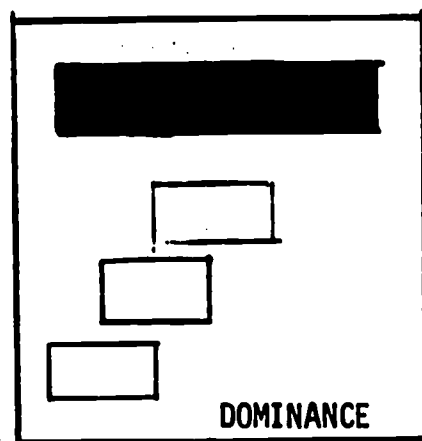
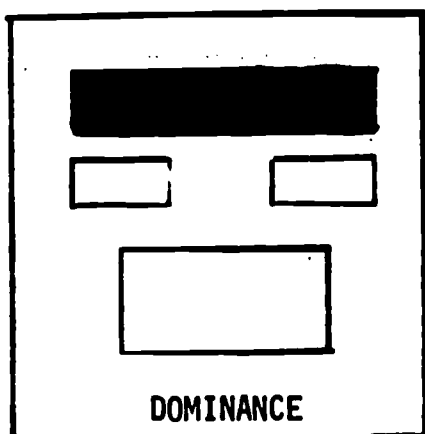
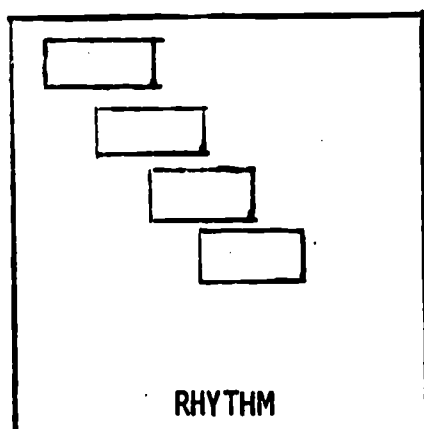

METHOD OF DISPLAY

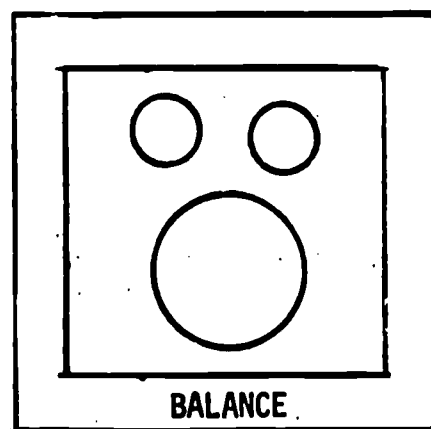

There are many methods of displaying parts of the transparency so as to give it continuity and to emphasize particular points.

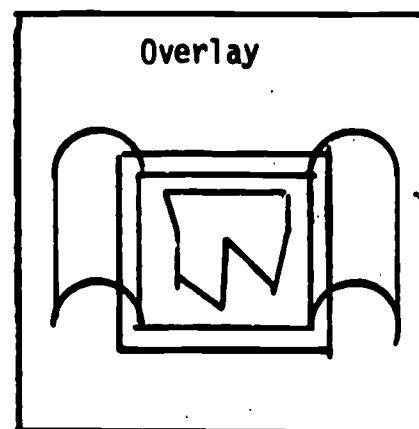
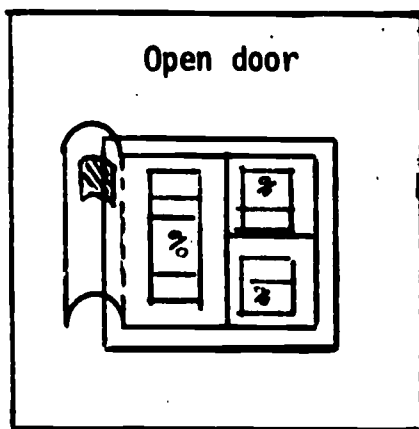
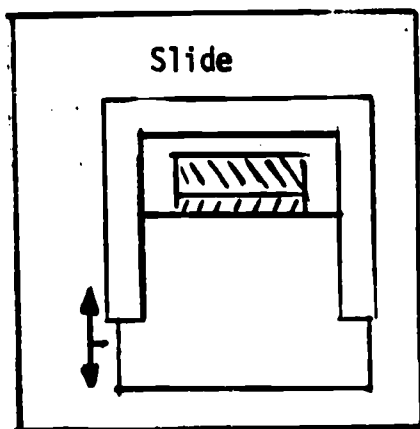

USES FOR TRANSPARENCIES

Material outline

Shadows of opaque material

Visual stimulus

Equipment

Prepared model

Test tube experiments

Self instruction

PRODUCTION

There is an almost unlimited variety of techniques, methods and processes available that can be used to produce transparencies. A few of the more popular methods will be outlined below.

Thermo-Fax

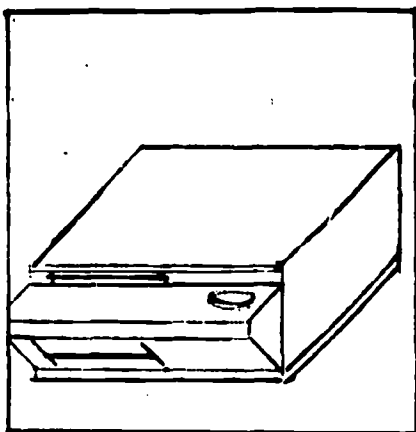

Heat Process

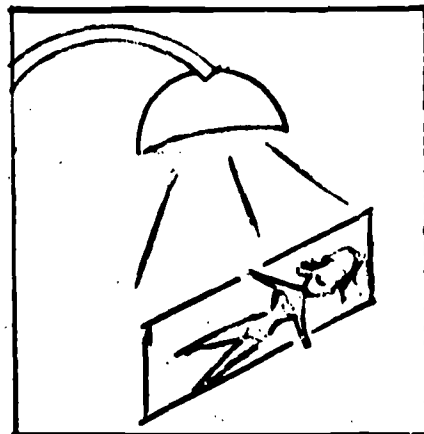

This produces the image on the transparent film by means of infrared heat. Therefore, the master must be made using lines which will conduct heat. Carbon base as are pencils, India ink, newspaper, zerox -- but not ball point, ditto copy, felt tip pens, grease pencils, etc.

Select transparency film type

(A)
Black image on clear
127,135,720

(B)
Color image on clear
infrared - 888

(C)
Color neg. image
on opaque - 128

(D)
Black image on
transparent color
129

Image Color - blue
orange
purple
green
red

Image color - clear
red
yellow
blue
green

Background color - yellow
red
blue
green

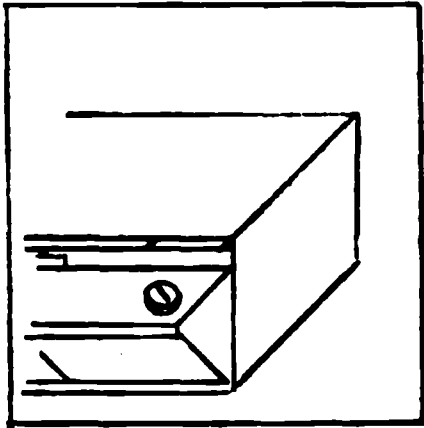

Adjust heat level

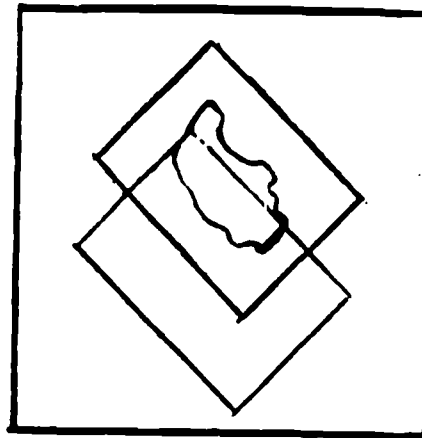

Place film over master with notch in upper right hand corner.

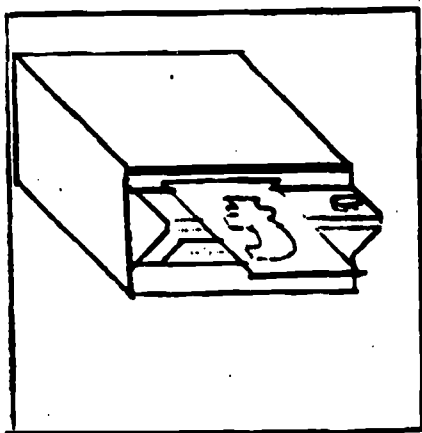

With transparency film on top start through machine.

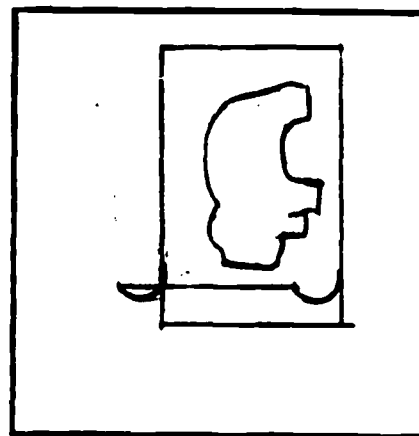

Separate transparency film from master.

DIAZO

As the name implies these are formed by chemical formation of nitrogen complexes. The translucent master allows ultraviolet light to pass through and expose the film which then is developed by ammonia vapor. (Do not inhale).

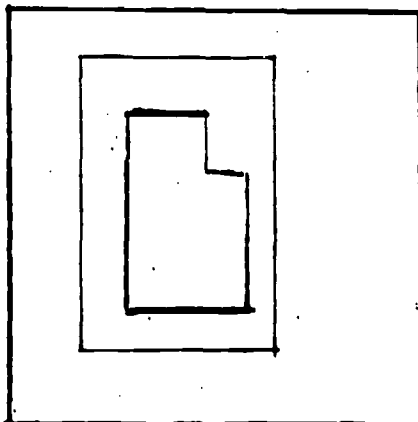

Prepare a transparency or translucent master

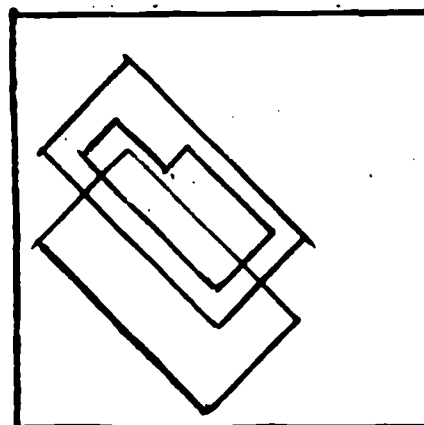

Place master over diazofilm

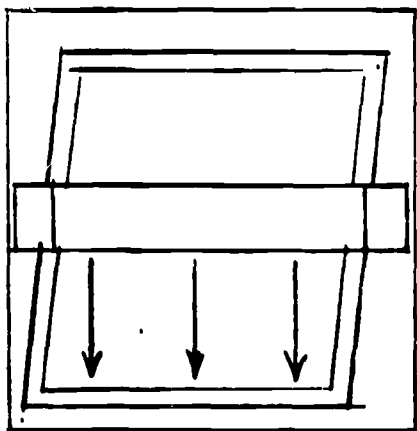

With master on top
expose to ultra violet
light.

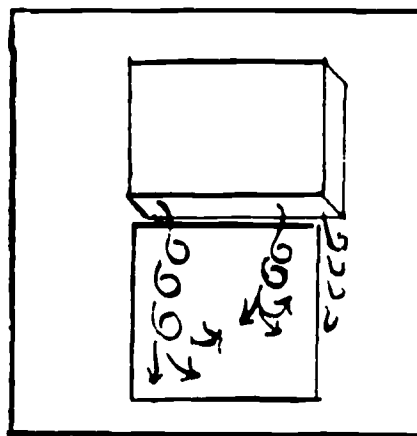

Develop film with
ammonia vapors.

COLOR LIFT

Utilizes the ink present in the original picture. The technique requires that the ink on the original picture has been applied to a layer of clay. Most magazine pictures are prepared this way and are therefore suitable for use in making color transparencies.

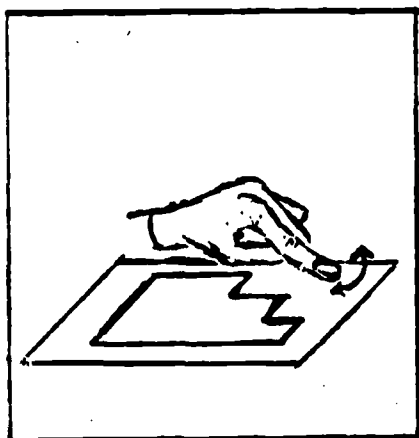

Determine if picture
is clay base.

Clay base principle

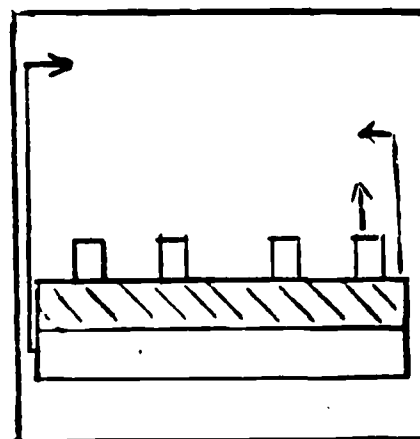

Ink
Clay
Paper

Moisten finger and rub corner of picture
with finger.

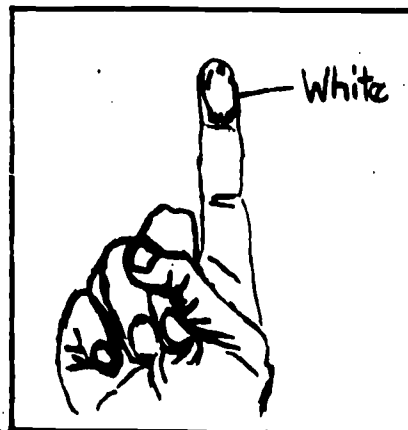

Clay base leaves
a white deposit.

Adhere plastic to surface of picture

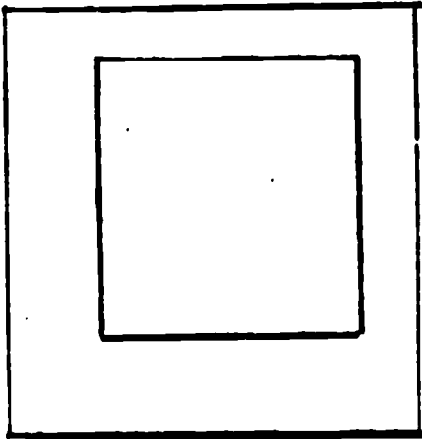

a. Clear contact plastic

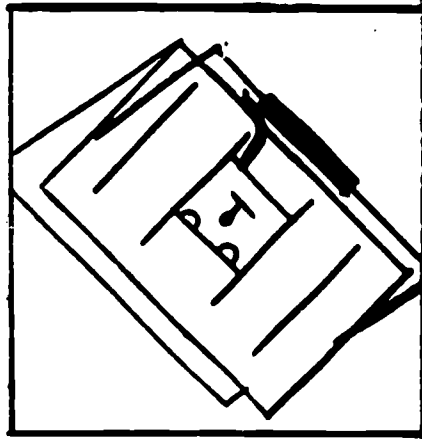

b. Dry mount press

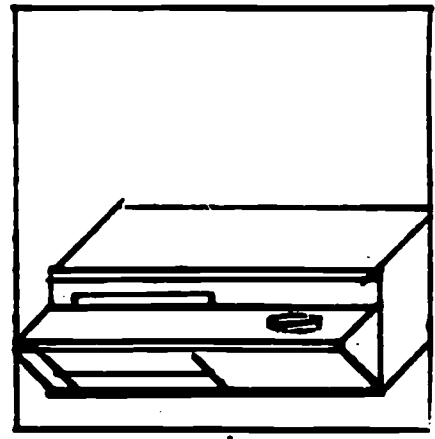

c. Thermofax

Separate clay from paper

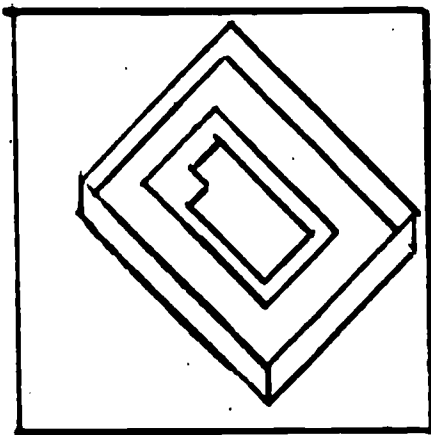

Place plastic coated picture in a tray or wash containing a small amount of detergent.

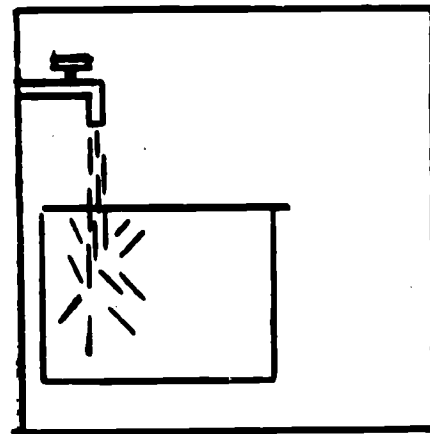

Wash excess clay from plastic using cotton or gauze, gently remove clay from plastic.

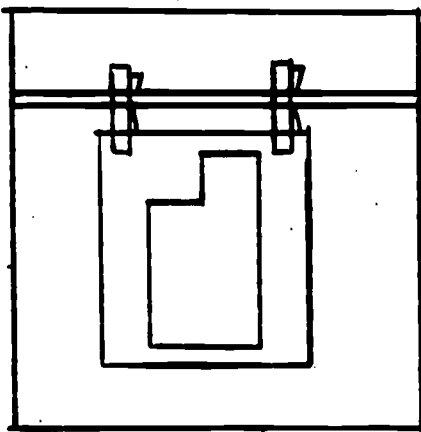

Let dry

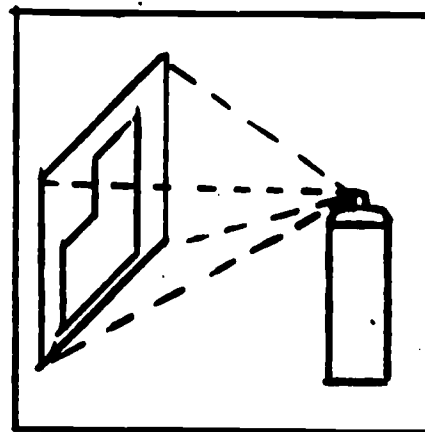

Make permanent by spraying ink side of transparency with lacquer or hair spray.

COLOR LIFT

A standard product is also available for color lift. Adhesive shelf covering, sold under various brand names, one of which is "Contact", can be purchased. Many colorful pictures from magazines and other resources may be prepared if the paper is clay-coated. To determine if paper is clay coated, wet a finger and rub on paper to see if a white chalky film comes off. Transparencies also may be made, as described on page 31.

1. Select a picture and the necessary materials.
2. Peel backing sheet from edge of contact.
3. Hold contact by two edges letting it form a "U" shape sticky side down.
4. Align contact with picture and lower until contact touches picture.
5. Continue lowering contact so it smoothly covers picture.
6. Rub contact until it is firmly bonded to the picture.
7. Soak in water several minutes then remove paper.
8. Gently wash remaining clay from picture.
9. When dry, spray with clear plastic or apply clear acetate to sticky side.
10. Mount in frame.

HANDMADE TRANSPARENCIES

Handmade transparencies may be made by using marking pens:

1. Make sample layout on paper.
2. Place clear acetate on top of layout.
3. Select marking pens with care to make sure permanent or temporary ink is used as desired. Colormaster transparent AV pencils may be erased if temporary product is desired.
4. With marking pens, ink in acetate following layout underneath.
5. When complete, mount acetate in frame, placing masking tape all the way around the back of the mount, with reading side toward front. Overlay should be fastened on front, at side or bottom, with masking tape.

THERMOFAX MACHINES

Volunteers can be very helpful to staff by making copies of original materials on thermofax machines, if original has black, carbon-base type ink.

TO PREPARE A THERMO SPIRIT MASTER

1. Make sure original material is a carbon base ink that will hold heat.
2. Remove slip sheet.
3. Use plastic carrier and place arranged material directly under carbon sheet.
4. Set correct heat setting on Thermofax dial indicator.
5. Run master and material through Thermofax.
6. Remove carbon and use master in duplicating machine.

MOUNTING PICTURES

Teachers often wish to mount pictures, because of flexibility of use, appearance, to protect the picture and ease of storage. Many flat pictures may be obtained from newspapers, magazines, photographs, calendars, posters and other sources. Any picture worth using is worth mounting, except pictures of current events. Advantages of a good picture file are to -

- translate abstract ideas into realistic context
- stimulate creative expression
- allow for group or individual study
- obtain materials from many inexpensive sources
- effectively combine with other media
- create for specific needs through photography.

Limitations of flat pictures -

- often too small
- lack dimensions, as size can be misleading
- lack motion.

Often students do not know what to look for in a picture. You need to have a real purpose for the picture and know why you are using it. Tell the students what you want them to look for through simple identification and interpreting the picture, describing what you see. Let students help you set up and pass pictures and be sure they are of interest to students. Pictures may imply movement. Do not use too many pictures, as a thoughtful, slow-paced examination of a few pictures is better than rapid-pace viewing of a lot. Ask questions to tell the story of a picture. The "Three C's" of using pictures are Content, Comparison, and Continuity. Some children are not orderly in sequence. Pictures may be used to identify important people for test questions.

Volunteers may be resourceful both in finding relevant pictures and in mounting pictures for school. Several methods will be described, both temporary and permanent. Mounting may be done in a formal or informal manner, but a margin will improve the final result. Railroad board is inexpensive, but construction paper should not be used, as it fades in color during processing.

RUBBER CEMENT MOUNTING

For temporary mounting, use a single coat of rubber cement. For permanency, follow these instructions:

1. Select picture and other materials.
2. Trim picture.
3. Align picture on cardboard, and make guide marks at each corner.
4. Coat the back of the picture, and the area marked on the cardboard with rubber cement (diluted about 2 or 3 to 1 with rubber cement thinner).
5. Let the cement dry.
6. Use two (2) pieces of wax paper, overlap them slightly (an inch or two) and cover the cemented area on the cardboard.
7. Align the picture on the cardboard using the corner guide marks.
8. Slide out one (1) sheet of wax paper, and smooth the picture. Remove the second sheet of wax paper, and smooth the picture.
9. Remove excess cement from cardboard.

LAMINATING A PICTURE - CONTACT

1. Select a mounted picture and the necessary material.
2. Peel backing sheet from the contact.
3. Hold contact by two edges letting it form a "U" shape sticky side down.
4. Align contact with picture and lower until contact touches picture.
5. Continue lowering contact so it smoothly covers picture.
6. Rub contact until it is firmly bonded to picture.
7. Trim excess contact.

THE DRY MOUNT PRESS

The dry mount press is essentially a large stationary iron. It can be used for:

1. dry mounting – adhering two pieces of material together by means of a sheet of adhering material.
2. sealaminating – adhering a clear plastic sheet over other material.
3. chartexing – adhering a cloth backing to other materials.

EXAMPLES OF USE

DRY MOUNT

Artwork
Exhibits
Instructions

SEALAMIN

Maps
Documents
Photographs

CHARTEX

Charts
Scrolls
Folders

The following are a few good rules for the use of the dry mount press.

Precautions

1. Keep press away from flammable materials when it is hot.
2. Protect the heating surface and pad by placing the material to be used in the press between two layers of newspaper.
3. Be sure the electrical wiring is adequate for heating equipment.

THE DRY MOUNT PRESS

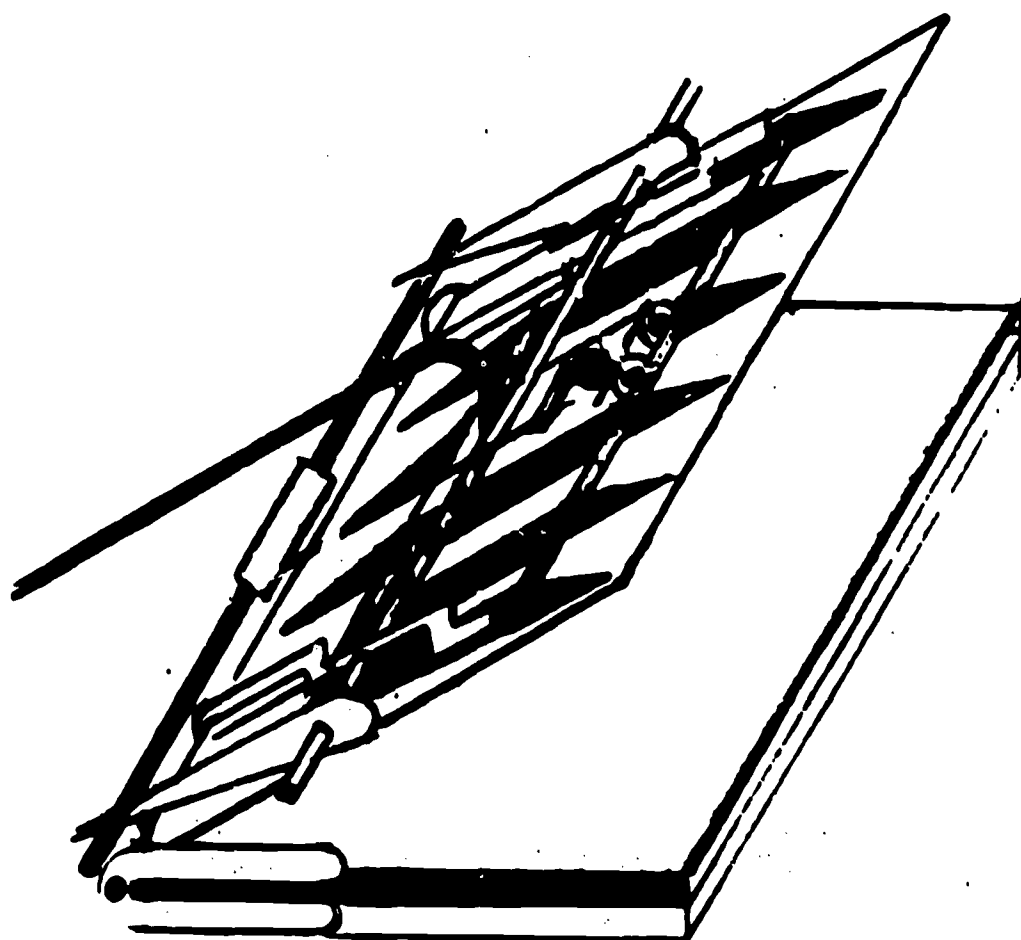

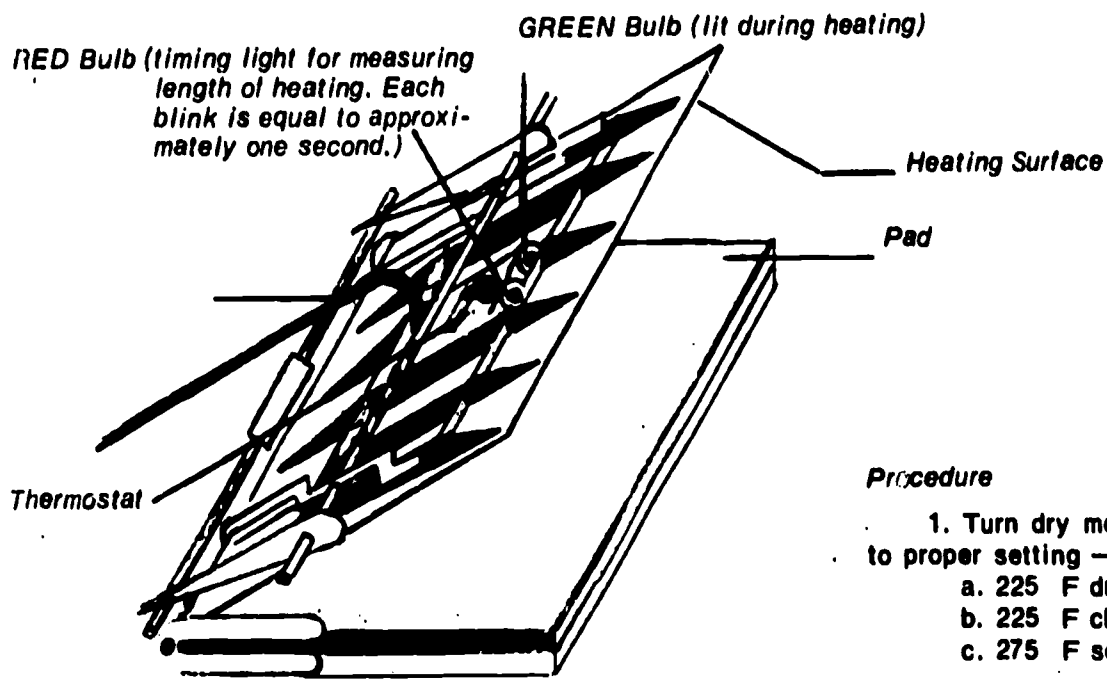

Procedure

1. Turn dry mount press on and adjust heat to proper setting –
 - a. 225 F dry mount tissue
 - b. 225 F chartex
 - c. 275 F sealaminate

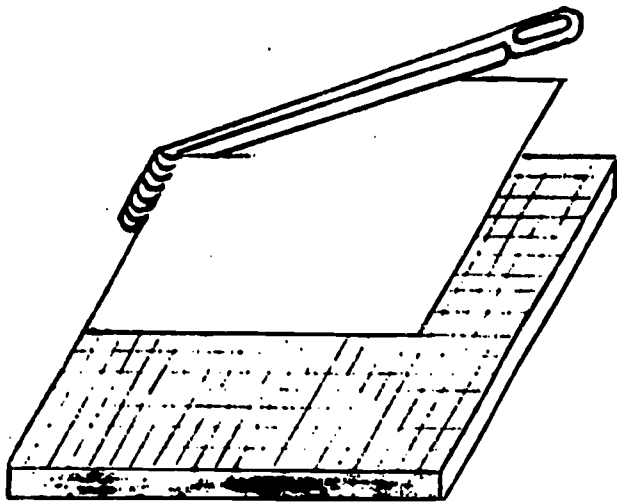

2. Cut material to be used, dry mount tissue, sealaminate, chartex, and project, to the correct size.

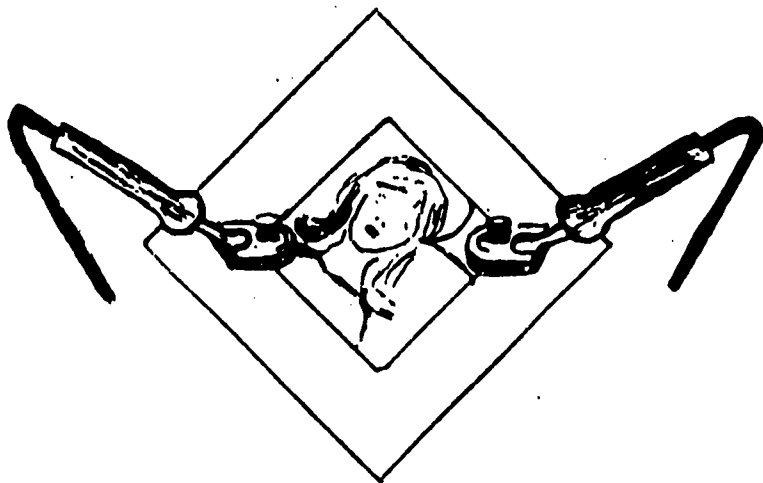

3. Tack material to the project with a tacking iron. This will prevent movement while the project and material are being placed into the dry mount press –
 - a. dry mount tissue-both sides will stick.
 - b. chartex-smooth side against project.
 - c. sealaminate-dull side against project.

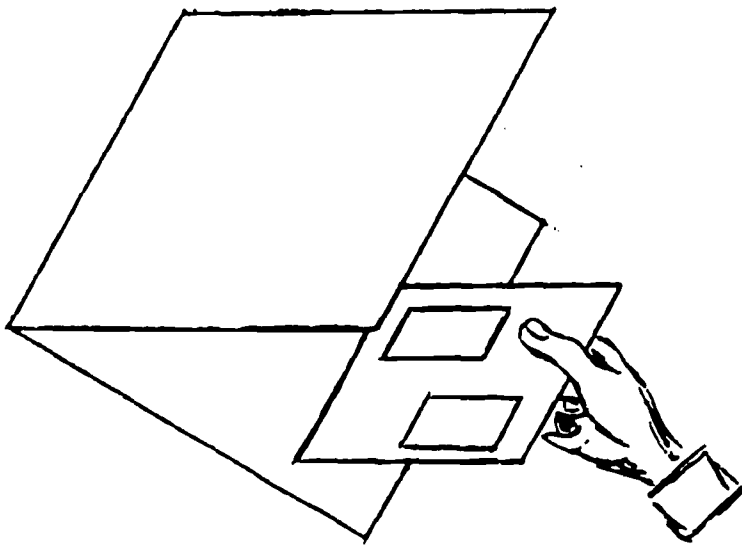

4. Place the project between two pieces of newspaper.

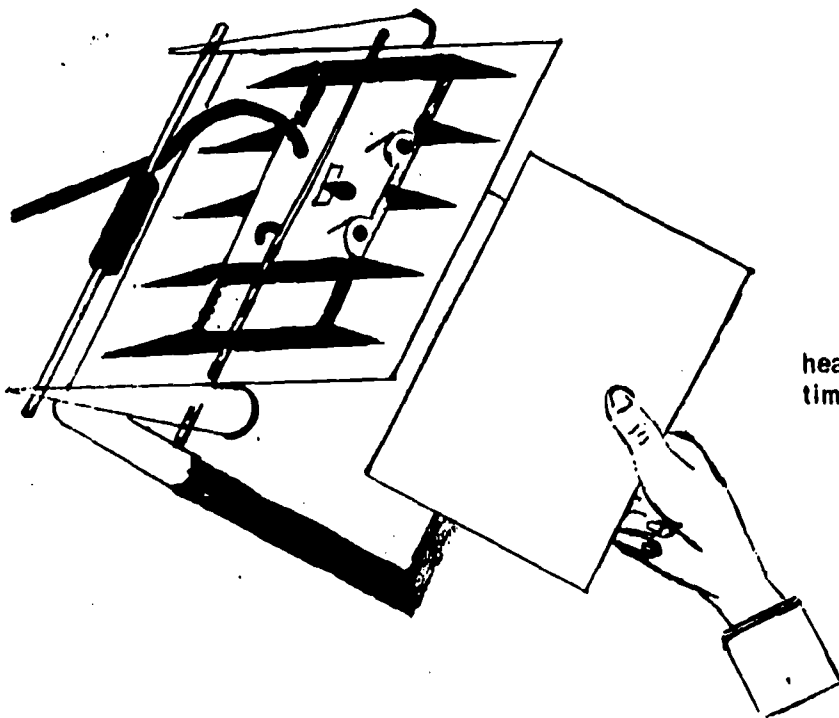

5. Place the newspaper and project into the heated press, close press for indicated length of time -

- a. dry mount tissue - 10 seconds.
- b. chartex - 5 seconds.
- c. sealaminate - 15 seconds.

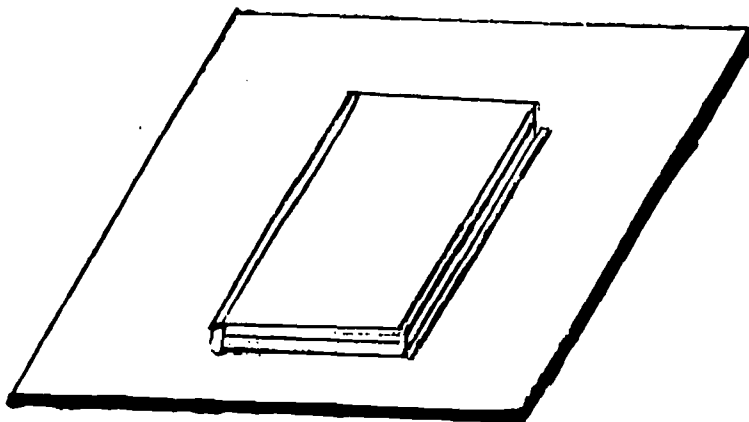

6. Remove project and newspapers from press and place under weights for 10 seconds or until cool.

RECORDERS

AUDIO TAPE RECORDINGS

Tape recordings are an excellent media for volunteers and children to utilize in reinforcing learning and to challenge a child in special interest areas. They may be utilized in quiet corners, such as carrels, or corners of the classrooms. A helpful tool in education, tapes are easily made, are available for immediate playback, may be edited for special use, are easily scheduled and duplicated, can be used with other media, such as slides and students like to use them.

Students, teachers and volunteers together can plan and prepare a tape:

1. Prepare a synopsis or outline of your script. Establish such things as characters, music, sequence, what voices, etc.
2. Write a first draft of your script, and read it over silently. If visuals are to be used, examine them as you read.
3. Read the script aloud and examine it for smooth reasonable flow. (If possible, make a trial tape.)
4. Rewrite the script as appropriate. Do not hesitate to rewrite at least parts of it when needed.
5. When ready to make the tape, check your equipment. Place microphone conveniently, establish correct recording volume. Make sure necessary materials, such as sound effects are at hand.
6. Record the script. If an error occurs, return to a convenient pause to start and re-record from there.
7. Listen to the tape for accepted quality. (If visuals are used, examine them while checking tape.)

Other than producing an original tape, there are many other possible uses of a tape recorder:

1. To provide a model of standard English and opportunities for improving listening skills for bilingual or disadvantaged students.
2. In Skill Areas
 - A. Reading
 - 1) To stimulate interest in reading through listening to teacher-recordings of stories.
 - 2) To stimulate interest through student's recording of stories.
 - 3) Use as "talking-textbook" by letting the student follow printed text as he listens.
 - 4) To encourage and stimulate favorable oral reading habits by the student.
 - 5) To increase skill in word attack skills with dictated lessons accompanied with printed matter.
 - B. Spelling and English
 - 1) To develop expanded spelling and English skills.
 - 2) To develop lessons and tests in easy steps to reinforce learning---will have self-checking features.

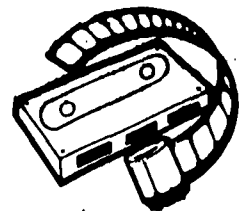

C. Math

- 1) Routine re-enforced learning and practice given on tape to sharpen skills with self-checking available.
- 2) Some math concepts might be explained on tape, particularly useful in individualized math.

D. Science and other areas

- 1) Some of the above ideas might be adapted such as "talking-textbooks" for material which a student may be able to understand but unable to read. A possible avenue for the below average reader to attain success. Direction for experiments can be put on tape.

3. Creative Student Participation

- A. To develop independent skills in use of electronic equipment. (Since students are growing up in a technological age of mass media, instant information, and computers they need at least an awareness and lack of awe for the various devices.
- B. To develop student cooperation in committee produced tapes.
- C. To encourage students to lead and develop lessons.

4. Tests may be on tape, with a volunteer as monitor.

5. Presentations by resource volunteer speakers may be taped for future reference.

OPERATION

Tape recorders are relatively simple machines to operate and instructions are often printed on the recorder platform or in the top of the case lid. Recorders are classified by the type of tape system they utilize.

- a. Reel -- the tape comes on a reel and is threaded on recorder to a take-up reel.
- b. Cassette -- the tape is permanently placed inside a plastic container, requires no threading into recorder and is transported from one reel to another.
- c. Cartridge -- the tape is permanently placed inside a plastic container that requires no threading and is usually endless (that is the ends connected and the recorded program will repeat automatically).

Since the reel to reel type is usually the most difficult to operate, it is used as an example for operation. Both portable recorders and larger classroom models are easily used. Diagrams of a Revere-Wollensak (Figure 8) and Sony (Figure 9) recorder are illustrated.

REVERE-WOLLENSAK TAPE RECORDER

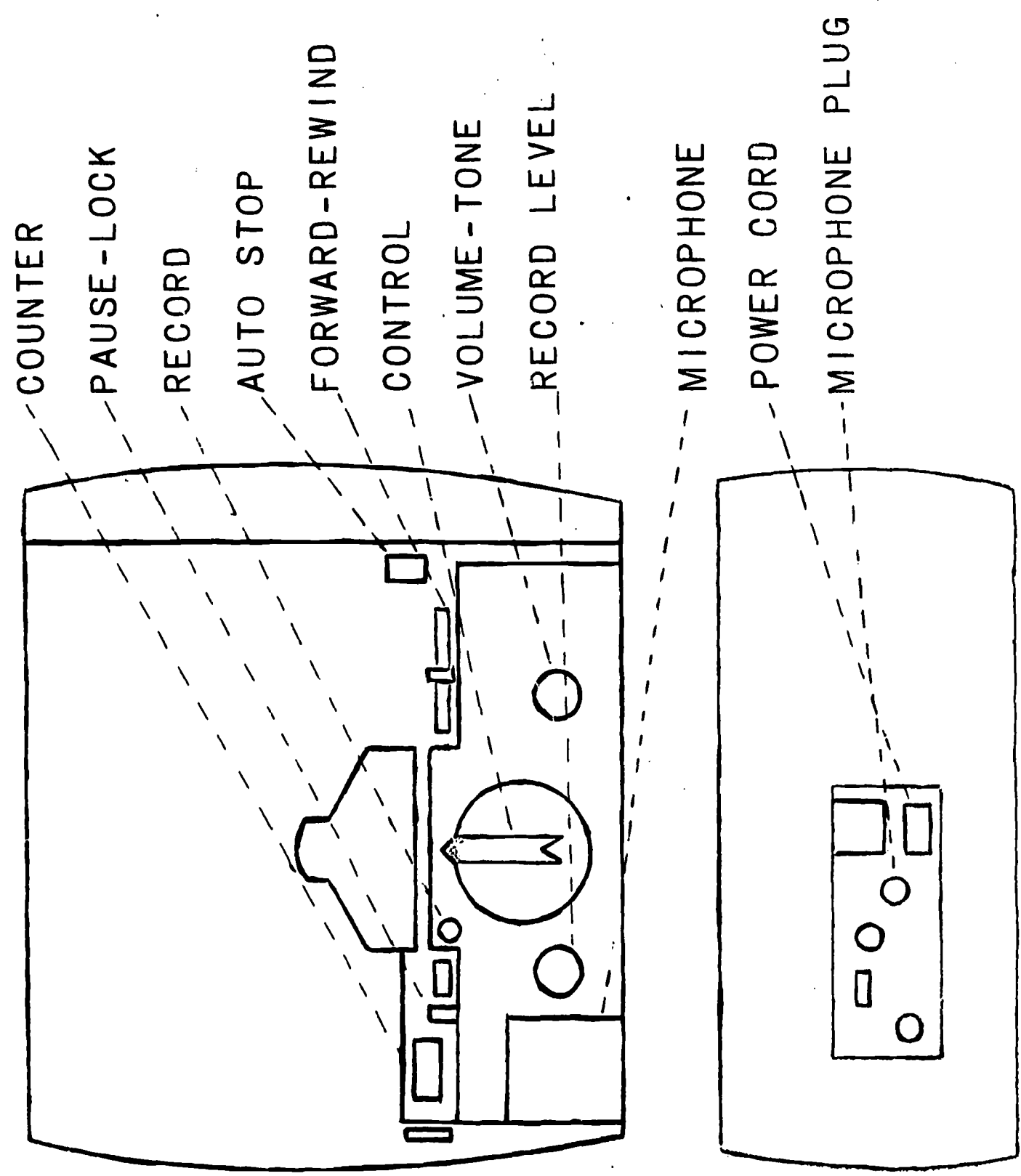
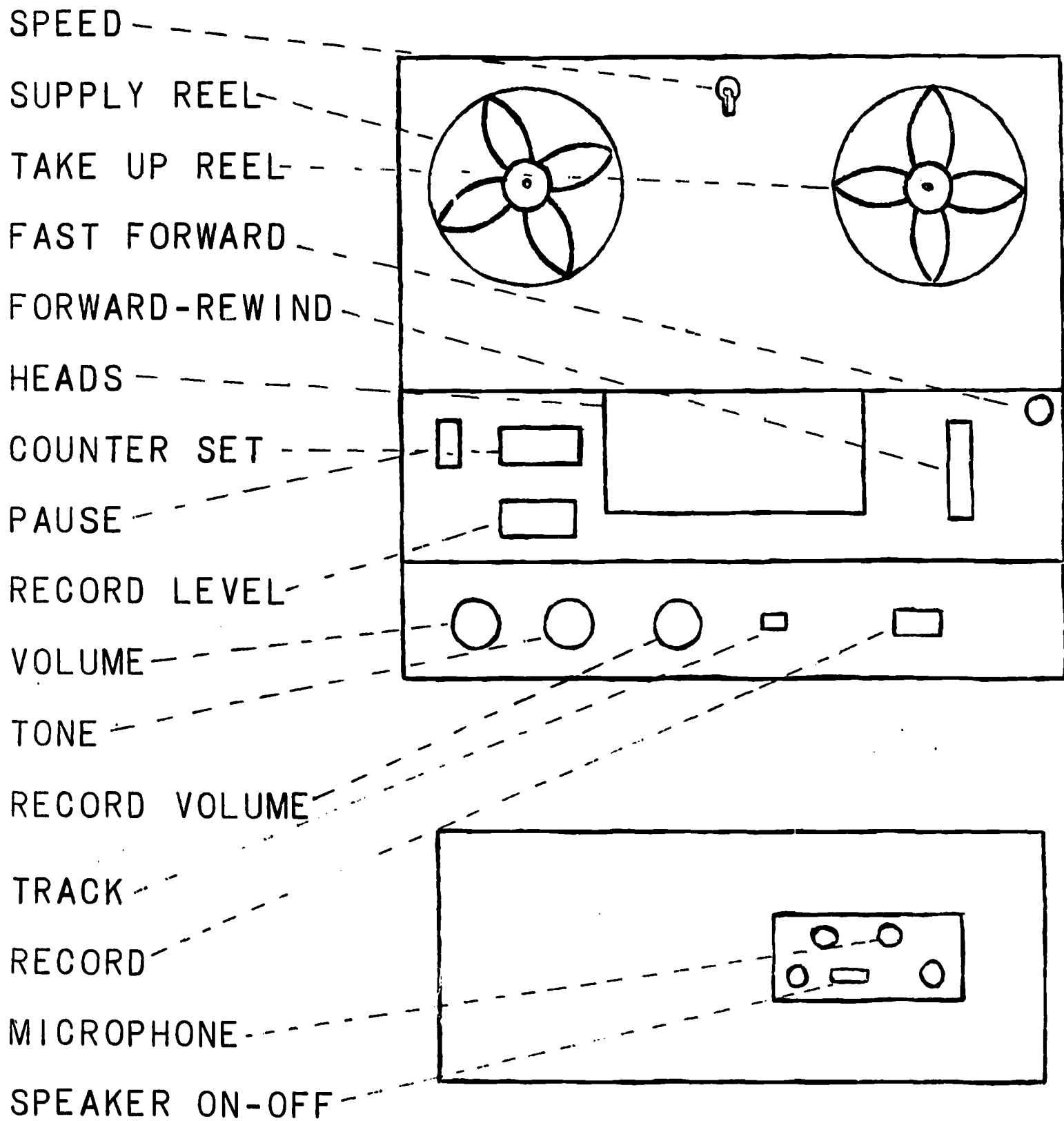

Figure 8

SONY TAPE RECORDER



43/41

-47-48

Figure 9

OPERATION OF TAPE RECORDERS

General instructions for operating are presented here but further information that may be needed is presented with the picture of each recorder.

A. Set up

1. Place the recorder on a sturdy table so that the tape reels will be in a horizontal position. Only a few recorders will operate also with the reels in a vertical position.
2. The power cord is usually attached to the recorder; plug it into an electric outlet, and into the recorder if necessary.
3. Locate the controls for PLAY, RECORD, REWIND, FAST FORWARD, and STOP. Note that the record control has a safety lock that must be operated before the recorder can be set to RECORD.
4. Locate the microphone input socket, external speaker socket, monitor switch, recording indicator, tape indicator, and threading path of the tape. Plug in the microphone and put the monitor switch on OFF.
5. Put the recorder switch on play and see that the spindle for the take-up reel turns. (Some recorders have an automatic stop and will turn themselves off unless threaded with tape.)
6. Put the recorder on RECORD, speak into the microphone, watch the record indicator, and adjust the volume control to obtain a proper recording volume on the record indicator. Do not blow into the microphone; to do so may damage some microphones.
7. Put the recorder on STOP.

B. Thread

1. Place an empty tape reel on the take-up spindle, and a reel of tape on the other spindle. Note that the tape should be wound with the dull (iron oxide) side toward the inside of the reel.
2. Thread the tape through the recording slot and through any tape guides along the path of the tape. Insert the tape in the hub of the take-up reel and turn the reel several rounds. Note that both reels turn in the same direction.

C. Operate

1. Put the recorder on RECORD or PLAY as desired. If you are recording, set the tone control on treble and the volume control so that the record indicator shows the proper volume. Speaking with a normal-to-strong voice makes better recordings as a lower volume control setting will give a good recording with less background noise. Any previous recording on the tape is automatically erased when the machine is set on record. The record safety lock is to prevent accidental erasure of a recording.
2. If you are playing a tape, set the volume control on LOW when starting the machine and then adjust the control to desired volume as the program starts playing. Set the tone control for a pleasing quality.
3. A tape must be rewound after it is recorded before it can be played. The second track on the tape can be recorded or played on the dual-track recorders by turning the tape reels over and running the tape through the recorder a second time. You should note that when both sides of a dual-track tape have just been recorded or played, the reel of tape is ready to play the first track.

D. Pack up

1. Rewind all the tape on the supply reel. If the tape has been broken, splice it. Splicing instructions are given in the last part of this chapter and on most tape boxes.
2. Unplug the microphone and place it in the proper place in the case.

3. Remove the reel of tape from the machine. On some recorders the reels must be removed before the recorder lid will close.
4. Unplug the power cord and place it in its place in the recorder case.

SPLICING

A good splice is never heard; it must be strong and lasting; it must not get gummy or sticky with age. These tips will assure noise free splices:

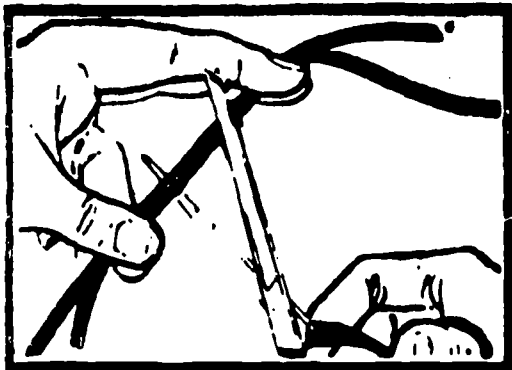

1. Overlap the ends of the magnetic tape to be spliced and hold securely between the fingers. Cut at a shallow angle - about 45 degrees - for maximum strength and flexibility of splice. Avoid a perpendicular cut (which may pop on replay) or an excessively long diagonal cut (which tends to peel at the splice).

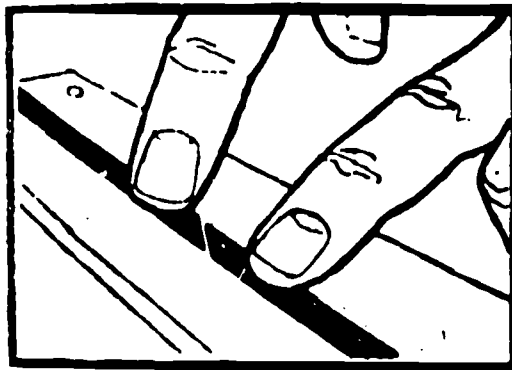

2. Butt the cut ends of the tape without overlapping them - shiny side up.

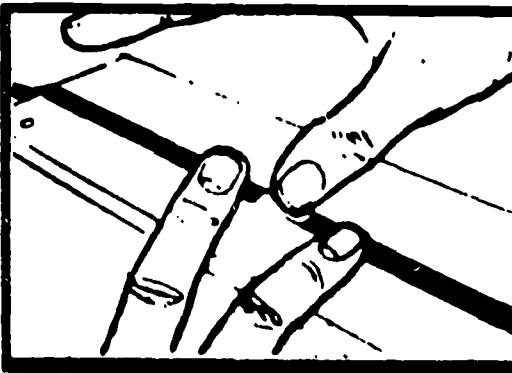

3. Apply a small section of splicing tape parallel with the magnetic tape. (APPLY ONLY TO SHINY SIDES.) Rub splicing tape firmly with fingernail to iron out air pockets for positive adhesion.

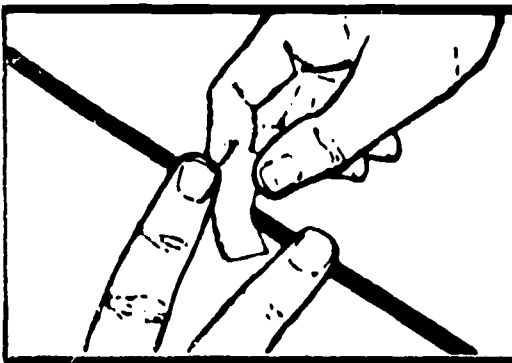

4. If splicing tape is wider than the magnetic tape used, trim off excess, cutting into magnetic tape very slightly. This eliminates danger of exposed adhesive gumming up the recording head or sticking to the adjacent layer of magnetic tape.

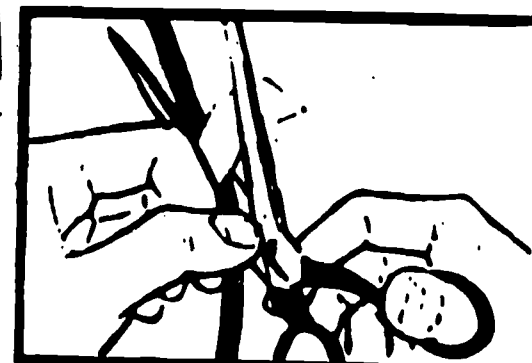

When splicing, always use pressure-sensitive tape designed expressly for use with magnetic tape. This tape is specially formulated so that it will not "bleed", harden or turn brittle and ruin the splice. Standard tapes were not designed for the particular requirements of splicing and, if used, may not hold, or may ooze adhesive onto the recorder head.

PREPARATION FOR RECORDING

The quality of a recording depends primarily on proper microphone use and on regulating volume level. Follow these practices:

If possible, attach the microphone to a stand so it cannot be handled or moved during recording.

If a stand is not available set the microphone on a table with a sound-absorbing towel or blanket under the microphone.

Determine by test the best distance from the narrator's mouth at which to place the microphone (about 10 or 12 inches) and have him speak across the front of it rather than directly into it.

Make a volume-level check for each voice to be used. Select a moderately high volume setting, but one below the distortion level. This setting permits greater flexibility for controlling volume during playback.

Be sure to turn off fans and other apparatus that make noises which may be picked up by the microphone.

Set the script on a music or other stand so the narrator will not have to handle the script too much or lower his head while talking.

Have a glass of water nearby for the narrator to "lubricate" his throat if necessary.

DUBBING WITH A PATCH CORD

The use of a patch cord to duplicate eliminates the possibility of recording unwanted background noises and permits the recording of the widest frequency response. The patch cord should be connected to an output of the source to be copied and connected to an input of the tape recorder. The source of the material to be copied should be played at its normal playback level, and the tape recorder adjusted to the proper recording level.

Output Sources

Auxiliary output jack
External speaker jack
Preamp output jack
Speaker terminals
Headphone jack

Input Sources

Auxiliary input jack
Microphone jack
Preamp input jack
Record/phono jack

TAPE TYPES AND TIMES

Length and Time
Uninterrupted Recordings

Feet Speed	150	300	600	900	1200	1800	2400	3600
1 7/8 ips	15 min	30 min	1 hr	1 1/2 hrs	2 hrs	3 hrs	4 hrs	6 hrs
3 3/4 ips	7 1/2 min	15 min	30 min	45 min	1 hr	1 1/2 hr	2 hrs	3 hrs
7 1/2 ips	3 3/4 min	7 1/2 min	15 min	22 1/2 min	30 min	45 min	1 hr	1 1/2 hrs
Reel size	3"	3"	3"&5"	5"	5"&7"	5"&7"	7"	7"

These are examples of one-direction recording. If recording in both directions, playing time is twice as long. If you have any questions ask your audio-visual specialist for his assistance.

Cassettes

- C-60 cassette recording time 1 hour (recorded two directions)
- C-90 cassette recording time 1 1/2 hours (recorded two directions)
- C-120 cassette recording time 2 hours (recorded two directions)

Backings

Acetate

- Economical
- Won't stretch
- Good life

Polyester

- Weatherproof
- Double strength
- Lifetime service

Don't be over-awed by the variety of tape names and types you may encounter. At most you probably will use only three or four kinds to do everything you want. It comes down to four basic considerations:

1. Reel size
2. Recording time
3. Relative strength and/or durability
4. All-purpose utility or the ultimate in sound quality.

CARD READER

A card reader, one brand name which is a "Language Master", is another good device used by students, to free them from the group-paced restricted instruction and allow them to proceed with individualized reinforcement as prescribed. Repetitive activities in speech correction, foreign language, mathematics, science, word structure and spelling all may be reinforcing. The reader is easy to operate and can give both visual and audio stimulus as pictures or verbal or numerical symbols may be attached to the card for pictorial association. There are facilities for the student to respond orally. Commercially prepared cards are available on many topics. For a few cents each, blank cards may be purchased to prepare your own materials. Cards are erasable and reusable. The card readers are a good media for teacher assignment to volunteers to use in tutoring on a one-to-one basis, where teachers may diagnose and prescribe for a student needing additional activities.

SUGGESTED VISUAL USE WITH DIFFERENT
AGE GROUPS

TYPE OF AID	PRESCHOOL	PRIMARY	JUNIOR	YOUTH	ADULT
MAPS		Limited	Simple	Vital	Vital
GRAPHS		Limited	W/Care	Yes	Yes
DIAGRAMS		Simple	W/Care	Vital	Vital
SINGLE CHARTS	Yes	Yes	Yes	Yes	Yes
FLIP CHARTS	Yes	Yes	Yes	Yes	Yes
FLASH CARDS		Yes	Yes	Yes	Yes
POSTERS	Yes	Yes	Yes	Yes	Yes
PICTURES	Yes	Yes	Yes	Yes	Yes
PHOTOGRAPHS OR HALFTONES	Yes	Yes	Yes	Yes	Yes
DRAWINGS OR SKETCHES	Yes	Yes	Yes	Yes	Yes
STICK FIGURES	Yes	Yes	Yes	Yes	Yes
BULLETIN BOARD DISPLAY	Yes	Yes	Yes	Yes	Yes
PEGBOARD DISPLAY	Yes	Yes	Yes	Yes	Yes
CHALKBOARD PRESENTATION & CHALK TALK	Simple	Yes	Yes	Yes	Yes
FLANNELBOARD PRESENTATION	Basically Stories	Stories & Applica- tion	Stories, Appli- cation, and Charts	Charts, & Lesson Outlines	Charts & Lesson Outlines
MAGNETIC BOARD	As above	As above	As above	As above	As above
STORYBOARD	Mainly stories	Stories, Memory work	Stories, Memory work	Memory work	Memory work
HOOP & LOOP BOARD	Yes	Yes	Yes	Yes	Yes
OBJECT LESSONS	Very simple	Not sym- bolic	W/Care	Yes	Yes
MODELS	Yes	Yes	Yes	Yes	Yes
TABLETOP DISPLAY	Yes	Yes	Yes	Yes	Yes
SLIDES	Use like pictures	Yes	Yes	Yes	Yes
FILMSTRIPS	Ones made for them	Yes	Yes	Yes	Yes
OPAQUE PROJECTOR	Limited	Yes	Yes	Yes	Yes
OVERHEAD PROJECTOR		Yes	Yes	Yes	Yes
3-D VIEWERS	Unlikely	Yes	Yes	Yes	Yes
MOTION PICTURES		Yes	Yes	Yes	Yes
PUPPETS, MARIONETTES	Yes	Yes	Yes	Limited	Limited
ROLE PLAYING	Yes	Yes	Yes	Yes	Yes
FIELD TRIPS	Limited	Yes	Yes	Yes	Yes

CHAPTER THREE

SIMPLIFIED MEDIA TECHNIQUES

BASIC GRAPHICS

Graphics are a kind of shorthand to assist students to understand communication, and to give information in a capsule form. Printing, photography, graphs, charts, posters, cartoons, etc. are all graphics, and some texts say maps and globes also are graphics. There are many good sources, some free from government, business and industry, and others are available at very low cost; they also are easily made.

Advantages of graphics are -

- information is summarized
- facts and processes are taught
- ideas are related
- attention is attracted
- students, teachers and volunteers can make them
- materials are easily obtained
- wide variety of materials can be used
- production may be done quickly

When making your own graphics, watch the fundamentals of design, which are pattern, harmony, balance and rhythm. Elements of design are line, shape, texture, value, color and volume.

When presenting visuals, keep the following in mind -

- present one idea with each visual
- keep it simple
- organize the layout
- be legible
- keep in balance

GRAPHS

A special kind of reading skill is needed to read or analyze graphs and students must be taught how. The four kinds of graphs are -

- line - continuing chart
- bar - compares
- circle - shows division of whole
- pictorial - symbols used

CHARTS

Three types of charts may be made to depict the message:

Flow Chart -

Stream
Tree
Organizational
Process (arrows from one step to next)

Data Chart -

Time lines
Tabular chart
Outline

Sequence Chart -

Strip
Flip
Experience

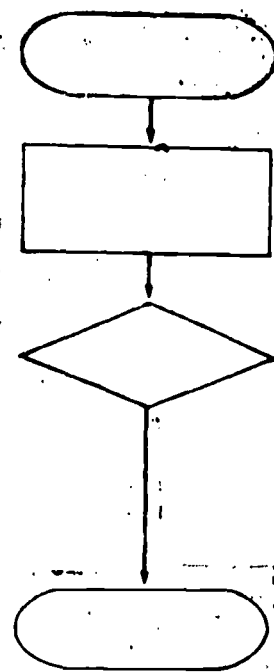

BULLETIN BOARD

Bulletin boards may be the focal point of a classroom, where seasonal or special event projects are featured. Students enjoy working on them, but skillful leadership is needed to supervise and create this task. Volunteers may supply the motivation for a shared and pleasant performance, or may assist teacher in planning and designing the board. Design may be formal or informal, with an informal placement of items at random being preferable. There are many advantages to be considered -

materials are easily obtained
expense is minimal
notices and announcements may be posted
study materials and student work is displayed
interest and discussion is stimulated
student can view materials at own pace
teaching environment is improved

In creating bulletin boards -

plan for effectiveness
make sketch of idea
organize materials
invite attention with captions
make it interesting, attractive, and innovative
change periodically

Materials used may include -

- attractive background material
- readable title - using 2 inch letters
- reproductions of pictures, obtainable at low cost
- drawings
- three dimensional objects

FLANNEL BOARD

Flannel boards are frequently used by elementary teachers, and are extremely versatile and useful in most subject areas. Children are fascinated to see items cling to the board, as if by magic. Best of all, flannel boards are easy to make, and volunteers may wish to have a small one of their own. A stiff backing material, such as vertex or cellox, 3/8" or 1/2" makes a sturdy but reasonably light weight frame. For smaller boards, corrugated or heavy pressed cardboard can be used. Felt or flannel is stretched over the backing materials so that items with nap or course texture will hold when placed on the surface. Some school supply catalogs carry a special material designed for making flannel boards, but felt or flannel can be purchased at most yardage shops. Inexpensive, lightweight cotton flannels should not be used, as they do not have good holding power.

The best way to fasten the material to the backing is with a dry mount press. Tack mounting tissue to the front of the board, stretch the cloth across the board and place in the press. Another method is to use upholstery cement, usually available in household and auto upholstery shops, and it will not bleed through the material. Fabric can be stapled or hand sewn on the board. A large envelope or pocket on the back of the board is a good place to hold scraps of flannel or felt so they are readily available to make needed items. Old books and magazines are good sources of words, pictures, shapes and figures to cut and use on the flannel board.

Light items backed with a material with nap or a course texture will adhere to the board. Items made from felt, styrofoam or pella interfacing from the yardage shop are good. Course sandpaper makes a good backing for drawings or pictures. Flannel boards can be used to illustrate stories or for students to tell about their own experiences or fantasies. Word building exercises, various math activities, diagramming, matching pictures with beginning, ending or vowel sound letters of word, prefixes or suffixes to words, all are good exercises for lower grades. In the upper grades, they may be used to compare fractional parts or do math drills. The flannel board should be tilted at an angle for best viewing.

POCKET CHART

The pocket chart is another very useful item in the classroom, and simple to make. A stiff backing material such as corrugated or pressed cardboard will work fine for small pocket charts. Fiber wall board, available at lumber yards under the trade names Vertex or Celotex, 3/8" or 1/2" thick, will work

better for the larger room size pocket chart. The pocket chart itself can be made from Kraft (butcher) paper, available in many schools, in a variety of colors. The paper should be marked for folding at 3" and 3/4" intervals. (See sketch).

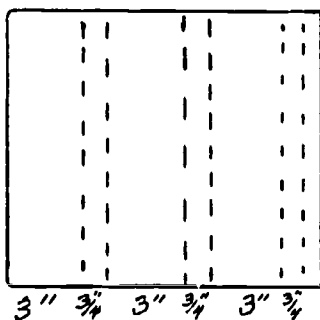

Lay the paper on the table and, starting at the left side, fold it up along the 3" marks, then back down along the 3/4" marks so it looks something like an accordion. The best method for fastening the folded paper to the backing material is with dry mount tissue. Cut the tissue in 3" strips, tack in place along the back. If a press is not available, various adhesive materials could be used. Many art stores have an adhesive available in spray cans that will not wrinkle paper or the double coated rubber cement method could be used. (See the directions on page 36).

The pocket chart can be used for word building, changing beginning or ending sounds, vowel sounds, prefixes or suffixes, spelling review (with wrong and right words), sentence building, outlining story sequence, building number sequence, and emphasis of particular points in any subject area. Older students can design steps in a science experiment or a recipe for home economics. New words in an experiment or story may be introduced.

CHALK BOARD

Chalk boards are the oldest media, and the most used and misused. The primary disadvantage is that your back has to be turned, if you are using it while talking. Many advantages are that material can be placed on chalk board ahead of time, presentations can be built in sequence from simple to complex, and students like to work on them. A volunteer may be helping one session while another group is at the blackboard, so those not involved will not watch those at board. Write large, at least 2 inch letters, and use a long piece of chalk with a pointer finger at top of chalk for firmness in writing. It often takes practice to write straight on the board.

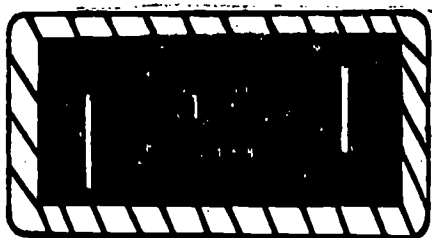

There are several ways a volunteer can use the blackboard to help the teacher:

1. Make a templet, which is a pattern of something that will be used a lot (such as your state), put on masonite, with a handle on it, to draw around with chalk.
2. Using an old window blind, making a drawing on it; punch holes in it at the outline, hang above chalk board and pat through holes with dirty chalk eraser to make outline of designs often used.
3. Project picture on board from opaque or overhead projector and then draw same, on board, with white and/or colored chalk.

It is possible to see a sample of each student's work in just a moment if they are using individual chalk boards. When introducing a new arithmetic procedure, students can work a sample problem on individual chalk boards and hold it up for the teacher to view. A quick glance will indicate any students who have errors and do not understand the procedure. It is possible to work with them immediately and correct their misunderstanding before the incorrect procedure becomes a set pattern like it does when they work fifteen or twenty problems on paper before the teacher has a chance to check their work.

Individual chalk boards are not difficult to make. Start with 1/8" tempered hard board, available in 4' X 8' sheets at lumber yards. This can be cut into 12" squares which will give thirty-two individual boards. In the upper grades 12" X 16" may be a better size, and you will get twenty-four boards from a 4' X 8' sheet. It is much easier to cut masonite with a power saw. If one is not available to you, some lumber yards will cut it for a small fee. Perhaps the principal could arrange to have the masonite cut by the maintenance department or in the high school shop. Sand the edges enough to remove any rough spots. Chalk board paint, a good brush and some thinner can be obtained from most paint stores. If they do not have the paint, they can order it for you. It is available in different colors and often in spray cans.

Cover the masonite with a coat of paint, keep brush marks to a minimum and all going one way. Allow the paint to dry thoroughly and apply a second coat brushing at right angles to the first coat, again keeping brush marks to a minimum. After drying thoroughly, cover the board with chalk, using the piece on its side for the quickest way. This fills in the paint and makes erasing much easier.

Speak to your principal or custodian and see if some old used erasers are available. A small usable eraser can be made from these by sawing away the ends and sides that are worn. You can also use a piece of terry cloth or an old sock for an eraser.

Besides being used for math, the boards could be used for practice on spelling words, or dividing words into syllables. One primary teacher uses them for phonics and word building. For example, she says a word and the youngsters write the beginning or ending sound. Word building can be done in the lower grades by substituting beginning sounds, in the upper grades they can write a root word with different prefixes or suffixes. Some students

will write with less reluctance on their own chalk board than on paper, and there is less embarrassment if student is wrong, as only the teacher can see the answer.

PEGBOARD

Pegboards provide a good place to display objects, as well as being useful in teaching math and other subjects. Pegboards are usually made of hard board with holes evenly spaced across the board. Material can be obtained at hardware and discount stores or lumber yards in 4' X 8' sheets and 1/8" or 1/4" thickness; the quarter inch will probably last longer. Sometimes 2' X 4' X 4' sizes will be available, but the board can be cut in any size. A more finished appearance can be had by sanding any rough edges caused by sawing. If you do not care for the brown color, it is not difficult to paint the board.

There are a variety of metal pegs available in tool departments of stores. Shop around a little, as there is often quite a difference in price. Golf tees are relatively inexpensive, come in a variety of colors and will work well for many items on your board.

The round paper key identification tags that can be hung by a string on the pegs are useful with a pegboard, are inexpensive, and easy to write on. Primary students could arrange numbers in sequence. Other students could build place value columns for our regular numbers and in the upper grades for other bases. Language activities could include work with consonants, prefixes, suffixes or substitutions. Items could be classified in the lower grades, pictures with the same beginning sounds could be hung on the same peg or in the same column. The upper grades could arrange parts of speech, decimals, fractions, scientific terms, agriculture or manufacturing products. Students usually like to manipulate things and learn well when doing so. A pegboard gives an excellent opportunity for an active learning experience.

MAGNETIC BOARD

A magnetic board is really not magnetic but a sheet of metal to which magnets will stick. Magnetic boards are available commercially in different sizes but you can easily make one, using a cookie sheet that is not aluminum. A local sheet metal shop will cut sheet metal to any size you want, but be very careful with the edges. They may have razor sharp burrs that will need to be filed off. A couple of layers of plastic tape, available in various colors, may be placed along the edges to provide additional protection and a frame. You can use the metal the way it comes but it will eventually show rust spots. This can be prevented with paint of almost any color. Chalk board paint is good because then the board can serve double duty.

Sometimes it is difficult to get paint to stick to metal. You can help the paint adhere by washing the metal with soap and water and drying thoroughly. Generously cover the metal with regular kitchen vinegar and let it soak for twenty minutes or so. The vinegar will etch the metal ever so slightly and

provide a better surface for the paint. After the vinegar soaking, wash again in soap and water and dry thoroughly. Apply your paint. It is better to use two or three thin coats, especially if your paint is in aerosol cans. If you use chalk board paint, do not forget to chalk it in. (See the section on individual chalk boards). Holes can be drilled in the metal so the board can be hung up; however, the board is more functional if it is tilted slightly for use. A number of commercial materials are available to use with magnetic boards but it is easy to make your own and affix magnets to the back. A check through the catalog of most school or scientific supply houses will show magnets available individually, in flexible cords and tapes as well as in sheets. Most of these can be attached to the back of materials with an all purpose quick drying household glue.

Magnetic boards can be used on a reading readiness level by having students match letters or pictures. The lower grades could use magnetic boards in counting and other simple mathematic problems. In reading, words can be built by changing beginning, ending or vowel sounds. The upper grades will find magnetic boards useful when working with prefixes, suffixes, fractions and decimals.

REALIA AND MODELS

Real things (realia) can be put to excellent use as educational media. In a unit on Indians, pottery, blankets, baskets, jewelry or arrow heads could be brought to the classroom to enrich the learning task and make it more interesting. During a study of the earth, rock and mineral collections could be put on display. Teachers, students, parents and volunteers are excellent sources of realia for classroom use.

It would be nice if we could always use realia to make learning more interesting but various limitations such as time, size, distance, cost or hazard make this difficult. Many times models of dinosaurs, an atom, a mountain range or space capsule, can be used. When working with models, care should be taken to make sure students understand the size relationships. For example, the size of dinosaurs versus atoms, buildings versus mountains-- whatever the model, comparisons should be made to assure the understanding of correct size.

MAPS AND GLOBES

Perhaps never before in education has such a wide variety of maps and globes been available, including almost every conceivable type, from simple outline maps which can be reproduced on the spirit duplicator to complex political physical maps. Globes come in the long familiar classroom models or special globes showing special features. There are even globes to represent a satellite in orbit around the earth and others that can be written on with chalk or paint.

When working with maps and globes, care must be taken that students really understand what the symbols on the map or globe mean. Take particular care to help them understand the symbols used and where they can look to find what these symbols mean.

Maps and globes can provide economical, political, social, cultural and scientific information as well as surface features, boundaries and location of places. Volunteers who have traveled can utilize globes and maps when they visit the classroom to tell about their experiences.



FREE AND INEXPENSIVE MATERIALS

BIBLIOGRAPHY

Aubrey, Ruth H. Selected Free Materials for Classroom Teachers, Palo Alto, Fearon Publishers - 1965

Derer, Esther, Sources of Free and Inexpensive Educational Materials, Grafton, West Virginia - 1963

Educators Grade Guide to Free Teaching Aids, Randolph, Wisconsin Educators Progress Service - 1960-1968 (revised yearly)

Free Guidance Materials, Randolph, Wisconsin Educators Progress Service - 1964-1967

Educators Index of Free Materials, Randolph, Wisconsin Educators Progress Service 1966-1968

Free and Inexpensive Educational Materials, Chicago Quarrie Corp. - 1937

Free and Inexpensive Learning Materials, Nashville George Peabody College for Teachers - Current - \$1.50

Free and Inexpensive Reference Materials, Kurtztown, Pennsylvania Eastern Arts Association - 1956

Free Science Materials, Randolph, Wisconsin Educators Progress Service - 1961-1967

Free Social Studies Materials, Randolph, Wisconsin Educators Progress Service 1961-1967

Free Tapes, Scripts, Transcripts, Randolph, Wisconsin Educators Progress Service 1955-1968

Guide to Free Films, Randolph, Wisconsin Educators Progress Service - 1953-1968

Guide to Free Filmstrips, Randolph, Wisconsin Educators Progress Service 1964-1968

Kenworthy, Leonard S., Free and Inexpensive Material on World Affairs, New York Teachers College - 1965

List of Available Publications of United States Department of Agriculture, Washington, D.C., Government Printing Office - 1929-1968

Miller, Bruce Sources of Free and Inexpensive Materials, Riverside, California - 1967

Murphy, Robert W. How and Where to Lock It Up, New York McGraw-Hill - 1965

Osborn, Merton B. Sources of Free and Inexpensive Materials for Teaching Science 1966

Osborn, Merton B. Sources of Free Pictures, Riverside, California B. Miller Publications - No date

Pepe, Thomas J., Free and Inexpensive Teaching Aids, New York Dower Publications 1962

Salisbury, Gordon, and Sheridan, Robert Catalog of Free Teaching Aids Riverside, California - 1967

Selected United States Government Publications, Washington, D.C., Government Printing Office - Current - \$1.00

Sources of Free and Inexpensive Educational Materials, Chicago Field Enterprises Educational Corp. - 1958

Sources of Free and Inexpensive Materials, Champaign, Illinois National Council of Teachers of English - 1961

REUSABLE (RECYCLED) MATERIALS

ACOUSTICAL TILE		Many have interesting textures, some with pattern of small holes into which golf tees or other small sticks fit, for counting in math, or wrapping yarn or colored string to make geometric designs.
ALUMINUM FOIL	Margarine tubs Pie pans, large and small TV trays Wrapping paper Muffin tins	Crayon holders Water and paint containers Puppets Holder for paint, paste and tools Displays, letters, numbers Storage for numbers and counting pieces
BAGS	Burlap Paper Plastic mesh Plastic	Wall hangings, stitchery Carrying books and work home Weaving or stitchery Storing and carrying Keeping clay moist
BALLOONS		Numbered for math exercises Science experiment
BALLS	Cork, rubber, styrofoam, wooden	Counting
BALSA		Puppet heads
BARK	Pieces Sheets	Texture Feeling box
BEADS		Counting
BEANS		Counting Science
BLINDS	Bamboo Cloth Paper Plastic	Bulletin board or display Pull down chart Stitchery; charts Cut into geometric shapes Cut into squares and numbered
BONES	Wishbones Round steak	Feel box-shapes
BOTTLES		Experiments Storing materials
BOTTLE TOPS	Metal (pop, etc.) Cardboard (milk) Plastic	Number with tape Counting Planting

BOXES, CARDBOARD	Gift & Hosiery Match Shoe	Small theaters Miniature greenhouse Storage, frames Several stacked for filing cabinet, building sequences Cut outs
BOXES, PLASTIC	Berry Cheese Fruit and vegetable trays	Shapes and numbers Circles Geometric designs
BOXES, WOODEN		Storage
BULBS, LIGHT		Puppet heads
BUTTER TUBS	Plastic	Models
BUTTONS		Counting Designs
CARDBOARD CIRCLES	Pie discs Milk bottle caps	Charts, designs
CARDBOARD CONES	String core Paper cups	Designs
CARDBOARD CYLINDERS AND TUBES		Shapes Repeat designs (3-D)
CARDBOARD SHEETS		Drawing boards Chalk boards Designs
CARDBOARD SPOOLS		Wheels Circles
CANDLES		Experiments
CARTONS	Cottage cheese Milk Ice cream	Plaster molds Cut for shapes Building blocks Individual waste basket Circles and pie shapes
CANS, TIN	Juice, tuna, and assorted	Numbered for counting and building Science experiments

CARPETING	Samples, scraps	Feel box, texture Sound experiment
CATALOGS		Cut out pictures, numbers, items
CLOTH	Burlap Braid Cheese cloth Scraps Cotton Felt Hardware cloth Oil cloth	Bulletin board Texture Shadow boxes Miniature stages Puppets Numbers, designs Stitchery Designs
CLOTHES PINS	Plastic or wooden Wooden	Holding and clamping Counting dolls
COMB		Line designs in fingerpainting
CORN		Designs Counting Games
CORN COB	Whole or sliced	Texture Designs
CORN HUSKS		Soaked and dyed; shaped into figures
CORK	Balls Stoppers Sheets	Design Printing Numbers
COTTON	Balls Batting Swabs	Texture Sound experiment Painting
CUPS	Paper, flat bottom Paper, cone shaped Styrofoam	Designs and Molds Circles Storage Planting
DIVIDERS	Apple & orange boxes Candy & cookies	Texture and assemblage
DOMINOES		Assemblage and counting

ENVELOPES	All sizes	Keeping numbers, game parts, and letters
EGG CARTONS		Counting squares (may be numbered) Make animal models
EGG SHELLS		Mosaics
FEATHERS		Texture Design Weight comparison
FELT		Flannel board Numbers and shapes
FILTERS; FURNACE		Backing Design
FLOWERS	Artificial Real	Design Science
FOOD CONTAINERS OR TRAYS		Mold Frames Cut into numbers
FORKS	Plastic Metal	Repeat designs
FRAMES		For students' designs
FUR		Texture Sound experiment
GAMES	Parts, pawns, pieces, tokens Checkers Dominoes Tinker toys	Counting Math games Designs
GLASS JARS		Storage
GLASSES		Science experiments
GLOVES	Cloth Knit Leather	Puppets Unravel for yarn Cut into designs
INNERTUBES		Rubber shapes

JEWELRY	Beads	Counting
LEATHER		Texture Design
LIDS		Drawing circles Design projects
LINOLEUM	Scraps Squares	Linoleum block Printing
MAGAZINES		Cut outs Resource articles
MARBLES		Counting
MASONITE		Displays
NAILS		Design Measuring sizes
NATURE	Weeds Flowers Fruits Seeds	Science
NEWSPRINT		Displays
NEWSPAPERS	Advertisements	Math Design Resource articles
NUTS	Shells	Games
NYLON		Stitchery
OIL CLOTH		Shapes and numbers
PAPER	All kinds Shredded	Scratch paper Cut, paste, fold Write and draw Paper maiche
PAPER CLIPS		Assemblage Counting
PAPER BAGS AND SACKS		Capes, cut out for head, with numbers or symbols

PEBBLES		Paint numbers on each
PIPE CLEANERS		Figures, shapes Feel box
PLASTIC BOTTLES		Cut out letters, numbers, and shapes
PLASTIC PACKING	Styrofoam Polyfoam	Carving shapes
PLASTIC SHEETING	Garment bags	Put under work
RAFFIA		Weaving (Counting)
RIBBON		Bulletin board lettering
RINGS	Rubber jar Plastic Wooden	Games Counting
ROPE		Design
SAND		Writing in it Numbers
SANDPAPER		Tactile numbers and letters
SAWDUST		Texture
SCREEN		Spatter painting
SHELLS		Texture Mosaics Science
SHINGLES		Painting
SOAP		Carving
SOCKS		Puppets
SPONGES		Clean-up

SPOOLS		Assemblage Counting
STAMPS	Used postage Mounted	Computing postage adding and subtracting
STICKS	Coffee stirrers Ice cream spoons Toothpicks Tongue depressors Twigs	Designs Counting Letters and numbers
STRAWS	Cellophane Paper Plastic	Designs Counting
STRING & THREAD		Designs Mobiles
TAPE		Assemblage
TILE	Ceiling Ceramic	Texture panels Carving Display
TOYS		Games
WALLPAPER		Designs Bulletin board Letters and numbers
WOOD		Carving Display
YARN		Weaving Knitting (counting) Pictures

CHAPTER FOUR

APPLICATION OF MEDIA TO MATH TUTORING

TUTORING TIPS AND TECHNIQUES

The type of student to be tutored will undoubtedly have a negative image of himself in varying degrees. If he is in the early primary grades (2nd-3rd), he knows that his teachers think he has low ability but the student is not yet sure what his ability is. If he is in his later elementary years and still is continuously having trouble in school, then you can be sure that both he and his teachers have very low expectations of his abilities. He cannot concentrate for any length of time and with just the least bit of freedom he quits. Whenever he does his classwork, it is invariably poor. Continual failing only teaches a child how to fail.

These certainly are not unreasonable conclusions and behaviors when you look closely at what has happened. In early primary grades the student wants to think well of himself but everything points in the opposite direction. His teachers have seen only poor work so they certainly cannot think highly of him. His parents have seen only bad report cards. His peers know that he still uses last year's books, so they call him dumb.

These opinions are even more pronounced in the later elementary years, for they have been ingrained with years of failures. Classwork is consistently below standards of other classmates. Even more important is that he has found that he can eliminate failures by not even doing the work at all, for then no one can make a judgment as to whether he can or cannot do the assignments correctly.

A tutor must come in with a positive attitude and high expectations. You must concentrate on raising the child's self-esteem, his prestige and even his pride. If he can be surrounded with definitely positive self-influences for one hour a day, then maybe he will continue to think positively of himself. The effect of tutoring often is difficult to measure, and often there are not spectacular successes. The tutor must have faith in the child, be honest in his commitment to the program and his enthusiasm will rub off on the child. Liking a child means accepting him as he is, and working patiently for improvement.

The teacher who diagnoses the student's problems may wish to complete a Student Referral form found at the end of this chapter. The tutor is only strengthening an area of math which has already been taught. There are two areas in which children usually need help, either in learning their facts or understanding concepts. If some idea is not clear to you, consult the teacher who can give you some helpful advice for reinforcement. The volunteer gives the best help when he is comfortable and happy in offering services. Children are quick to sense uneasiness or insincerity. Often educationally disadvantaged

students find they can learn better from more advantaged peers than from conventional classroom instruction; student-tutoring-student programs have many advantages, both to tutor and tutee.

The following suggestions are recommended to accomplish the above esteem traits which you have been given the responsibility to improve, and to make math have meaning.

- 1) Make the session enjoyable. To do this, you must not make your session just like the classroom, where he is failing. The first few sessions are very important. Here are some suggestions:

First session - Definitely do not do any math on the first day, but just get to know your student. Discuss something he likes, such as baseball, collections, or his friends. An interest inventory may be helpful at this stage. You might even try a game of NIM (explained under "Things To Do") or any other game that doesn't involve the manipulations of numbers, and let him have the successes. Try not to discuss yourself; you are not the object of attention. When you have completed your first session, write down everything you remember about it, everything he did right, and review it before the second session so he will know you have been thinking of him.

Second session - Start the day with something good that happened last time (such as his beating you at NIM). Make sure that you carefully praise him. Don't overdo the praise, however, for he won't trust you if you are not sincere. It is probably alright to discuss his math class here and for him to let you know of his problems. Of course you are aware of these already, from talking to his teacher, but the child will give you a different view. You might end the day on some type of novelty, such as "hubcap, wiggle, or cheerio", depending on his grade level. Again take avid notes after the session.

Third session - Start the session with something positive from last time. Emphasize this time the regular class problems as diagnosed by the teacher, but do not give him the same old lesson as in his class. Disguise it in some other exercise. For instance, suppose he needed work on his addition facts. "Cheerio" would be a suitable diversion from the regular classroom activities for it would make him add to get a result, but the addition is disguised. Again end the session with something he can do easily and something he likes, possibly a harder NIM game. Take notes of the good parts of the session so they can be enhanced next time.

- 2) Never say "no" to the student. There are other ways of answering without introducing negatives. Suppose for instance he claimed that $5 + 4 = 8$. It is not necessary to tell him it is wrong. Let him find out by himself by asking him another question such as what is $5 + 3$? If he answers this as 8 then show him that he has said that $3 = 4$. It is important that he find the error rather than you pointing it out. An incorrect answer can always be called "close", which is a positive reply. Minimize the negative approach. Instead, help him explore his answers so that he will have the satisfaction of finding the correct solution. The satisfaction of succeeding, no matter how small, will raise his self-esteem.

An approach that might be used to improve the child's self-esteem is to find something personally nice to say about him, no matter how small the compliment might be. Rudolph Dreikers, a Chicago psychiatrist, says, "Encouragement is to a child as water is to a plant".

- 3) Never do routine drill in the form of a big page of endless problems. This type of busy work is not very pleasant and will kill any interest the student has. Necessary number facts (or at least methods of computing) can be retained in better ways through gimmicks, such as sequences, Happy-Sad, True-False, etc., as explained in the activities. Vary your activities, using part of the period to play a game or discussing the use of math in everyday business and pleasure. Look around your surroundings and see how many places in the room have numerals on them, such as a calendar, ruler, clock, book, etc. Or what may he see on the way home, such as license numbers, street signs, billboards, or prices on store windows? Practical, everyday applications relating to our environment are meaningful. Many students never seem to master the use of fractions, but once they are working on an hourly basis, whether it is mowing lawns, baby sitting, or sacking groceries, they quickly learn how to compute 4 1/2 hours at \$1.65 per hour.

Children in need of tutoring have very short attention spans, therefore variety is important! A shy child is reluctant to talk, so games, puzzles and blackboard work are helpful to improve his skills and confidence, and they encourage communication and personal rapport. Be sure the game has a mathematical goal, that the rules are well understood before you begin, and that they are used to reinforce concepts, not to teach them. Many games may be adapted to different age levels.

- 4) Short attention spans will demand that you do not spend too much time on any one topic during a session. Go to another topic just when the student has really become interested. It will be easier to come back to at a later date if you leave it when the student has an eager attitude. It may take practice on your part to find out when it is best to change topics. Be sure to come back repeatedly to every topic that the student enjoys. You may feel you are developing him too much in one direction but that is alright, for he will have a positive feeling for something he can do well.
- 5) Make the material meaningful to the student's environment. Do not make inner city kids count cows. It just is not relevant to their everyday lives. Let them count billboards, or cracks in the sidewalks, or cars. Cars also have lights, hubcaps, windows, bumpers, doors, seats and dents, which are handy for addition and multiplication facts. How many cracks from here to home? How many tires on 35 cars?

Definitely do not discourage finger counting. It is better than not counting at all. Their fingers are always with them and you would be surprised how easy they make some problems. The student someday will decide for himself that it is a very inefficient method, but in order to get him started, let him do it his way.



Underachievers may not hear the difference between sounds or not hear sounds at all, because they come from homes that are very noisy, due to the presence of so many people in a small space. They lack experiences which helps them recognize many objects and may have few toys. In the early grades children lack understanding of time concepts, such as "before" and "after"; and they lack space concepts, such as "in front of" or "in back of".

- 6) A child's life is filled with manipulative things such as pencils, paper, clothes, etc. Math also can be made manipulative by the introduction of an abacus. All that is needed is a piece of wood with nails on each end, and wire stretched between the nails, and some washers for counters. Addition, subtraction, multiplication, (and even division), can be quickly accomplished on the abacus and place values of numbers is a sidelight. Balance scales are easily incorporated into the solutions of equations. Cuisinaire rods are great to bring the abstractness of math to reality. You can also add, subtract, and multiply with cuisinaire rods. Geoboards have a lot of geometric, plus arithmetic properties. Manipulative devices strengthen the student's comprehension. Ask the teacher or school chairman to help you find materials. Most classrooms have place value sticks and rubber bands, pocket charts, counters and abaci.
- 7) Reviewing periodically is very important. Try not just to go back over the same problems, but introduce a new problem that uses the concepts of the old lesson, as incidental. Try to review when the student is in a good mood, or when he just recently has had some successes, so he will retain his skills.

Reviewing may also benefit the tutor. In the case of a high school student tutoring in San Francisco, he was assigned as a math tutor and found this to be a lucky break. Math was not his strongest subject and in order to tutor, he was forced to relearn much of what he had forgotten. This review came in handy when he took his college entrance exam in math.

- 8) You must let him know that you do care about him. Take notes after each session and make sure you noticed the good things that he accomplished on the last lesson. Make sure his teacher knows of his successes. The student will feel good if he can do something that his teacher or classmates can't do (hubcap, wiggle, or cheerio are examples). If he can teach one of these games to another child, a group, or the class, this would place him in an important position, and would raise his self-esteem.

New Math

New math or "modern math" is not really as new as you may think. In new math the sum of two and two is still four and the product of two and three is still six. Yet, there is a difference. The difference is in the language which is used to express ideas about numbers and the relationships of numbers. New terms and symbols are introduced to help you understand math better; to help you understand "why" as well as "how". You may learn that a number is an idea about how many (three), and a numeral is a name used to express that idea (3). The concept of sets may help you to understand quantity and the relationships of quantities and what really happens when we add and subtract quantities of things. Much of the New Math is simply a new way of looking at arithmetic.

What follows is not a complete course in new math. It is a presentation of some of the basic ideas or concepts which are learned in the study of new math. It begins with an explanation of sets which is an important and basic idea in new math.

SETS:

A set is a well-defined collection or group of objects or ideas.

The expression "well defined" means that the objects or ideas can be identified as belonging to the set. A set of books about horses is well defined because we can identify specific books as belonging to that set (e.g. Black Beauty). A set of good books is not well defined because we cannot identify specific books as belonging to that set. We cannot say for sure that Black Beauty belongs to that set because we cannot all agree that Black Beauty is a good book.

Examples of Sets:

1. A set of all days of the week
2. A set of former United States Presidents
3. A set of all vowels
4. A set of whole numbers between 1 and 10

ELEMENTS

The things that are contained within a set are called the members, or elements of that set. In the sets mentioned above an element of each could be:

1. Days of the week: Tuesday
2. United States President: Truman
3. Vowels: e
4. Whole numbers between 1 and 10: 7

The symbol \in is used to express the idea "is an element of". Example three above could be written $e \in$ a set of all vowels or $e \in [a, e, i, o, u]$.

KINDS OF SETS

- A. Finite sets:** The sets in the practice exercise are examples of finite sets. Such sets have a finite or limited number of elements. (There are only two days of the week beginning with "S"). The number of elements may be small or very large but still "countable" (e.g. all the automobiles in the United States).
- B. Infinite sets:** Sets which contain an infinite or unlimited number of elements are called infinite sets. An example of an infinite set is a set of all positive odd numbers which would be written: $[1, 3, 5, \dots]$. The three dots mean "and so on", and show that the set continues or is infinite.
- C. Null set:** The set which contains no elements is called the null or empty set. This set is designated by empty brackets $[\]$ or by the symbol \emptyset . An example of the null set is the set of all the months beginning with "R".

RELATIONSHIPS OF SETS

When we begin to deal with two or more sets, we find that sets may be related to each other in several ways. Sets may be related as a part to a whole as in the case of subsets and universal sets. They may also be equal to each other or equivalent to each other.

A. Subsets

It is possible to regroup the elements of a set into subsets. A subset of a given set may contain:

1. Any of the elements or combination of elements of the given set.
2. All the elements of the given set. (Every set is considered to be a subset of itself.)
3. No elements at all. (The null set is a subset of every set.)

Examples:

1. $[1, 2]$ is a subset of $[1, 2, 3]$ as are $[3, 1]$ and $[2]$
2. $[1, 2, 3]$ is a subset of $[1, 2, 3]$
3. $[\]$ or \emptyset is a subset of $[1, 2, 3]$

The idea that a set is a subset of itself and that the null set is a subset of every set is difficult to grasp. The example which follows may help to clarify this. (Remember that new math is simply a new way of expressing old ideas about quantities and relationships of things.) If we begin with a set of the members of a family [father, mother, son] we can group the elements of this set into eight different subsets.

A = [father] B = [mother] C = [son]
D = [father, mother] E = [father, son] F = [mother, son]
G = [father, mother, son] H = []

The last two subsets (G and H) are necessary if we wish to introduce a new relationship or idea about the members of this family. If we wish to form a subset of all the members of the family with brown eyes and all the members have brown eyes, then we must include all the members in the subset (G). On the other hand, if we wish to express the idea that none of the members of the family have blue eyes we must use the null set. Subset H may then be the set of all the members of the family with blue eyes.

Remember that a subset can be made of any or all or none of the elements of a given set. Note that a subset cannot contain elements which are not in the original set. A set of family members which contains a mother-in-law as an element cannot be a subset of the example given on this page.

The symbol which is used to express the idea "is a subset of" is \subset . For example, $[2, 4, 6] \subset [1, 2, 3, 4, 5, 6]$ means that the set containing the numbers 2, 4, 6 is a subset of a set of whole numbers from 1 through 6.

B. Universe or Universal Set

A universe or universal set is a large set of all the things that could be used in the described condition. The universe of a set is defined by the problem or the set we are dealing with.

The universe for a set of Iowans with ingrown toenails might be all Iowans. It could also be all people with ingrown toenails if we are concerned with identifying the Iowans with ingrown toenails among all the people who have ingrown toenails. The universe for a given set of whole numbers might be all whole numbers.

It would not be logical to consider a set of all living animals to be the universe for a set of letters of the alphabet. It would be logical to define the universe for such a set as all symbols used for written communication.

The capital letter U is the symbol used to designate a universe.

The diagram below, called a Venn diagram, illustrates the relationships between a universe, a set, and a subset.

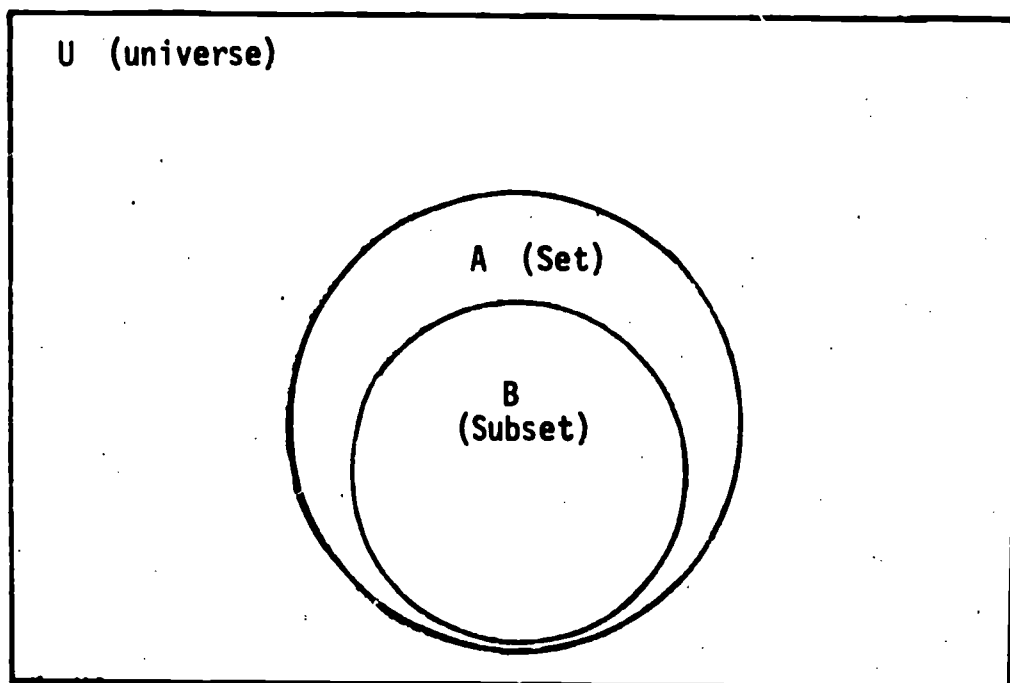

In the diagram:

1. The rectangle pictures the universe.
2. The larger circle pictures a set called A.
3. The smaller circle within the larger circle pictures a subset called B.

In this case an example might be:

1. U = all even whole numbers
2. Set $A = [2, 4, 6, 8, 10]$
3. Subset $B = [6, 8, 10]$

Another example:

1. U = all living United States citizens.
2. A = all living United States citizens over age 100.
3. B = all living United States citizens over age 100 who are residents of Iowa.

C. Equal sets

Equal sets are sets which contain exactly the same elements. The elements need not be in exactly the same order. For example, $[7, 8, 9] = [7, 8, 9]$ and $[x, y, z] = [y, z, x]$.

D. Equivalent sets (matching or one to one correspondence)

Sets are considered equivalent when they contain the same number of elements. The elements need not be exactly the same. For example, $[3, 6, 9] \longleftrightarrow [\text{cat, bat, hat}]$ (The sign \longleftrightarrow means is equivalent to). Such sets are also called matching or in one-to-one correspondence. Another example: $[1, 2, 3, 4, 5] \longleftrightarrow [E, D, C, B, A]$.

OPERATIONS WITH SETS

A. Union

A union of sets is an operation in which the elements of two or more sets are joined together to form a new set. If set $A = [a, b, c]$ and set $B = [x, y, z]$, the union of set A and B would be $[a, b, c, x, y, z]$.

The symbol for union is \cup . ($x \cup y$ would be read "x union y"). The above example can be written $A \cup B = [a, b, c, x, y, z]$.

It is important to remember that the elements of each set are used only once in the set formed by a union. For example, if set $A = [1, 2, 3]$ and set $B = [3, 4, 5]$ then $A \cup B = [1, 2, 3, 4, 5]$.

B. Intersection

An intersection of two sets is a set which contains elements which belong to both sets. If set $N = [8, 9, 10, 11, 12]$ and set $M = [10, 11, 12, 13, 14]$, the intersection of sets N and M would be $[10, 11, 12]$. The numbers 10, 11, 12 are the only numbers which belong to both sets.

The symbol for intersection is \cap . The above example can be written $N \cap M = [10, 11, 12]$.

SOLUTION SETS

A solution set is a set of all possible replacements for a variable in a true mathematical sentence.

A variable is a letter or symbol which stands for an unknown part of a mathematical sentence, and which can be replaced by a specific number.

A mathematical sentence is a statement in mathematical terms (numerals and symbols). For example, $3 + 16 - 6 = 13$ is a mathematical sentence which states "three plus sixteen minus six equals thirteen." It is a true statement.

In the mathematical sentence:

$$N + 4 - 2 = 5$$

1. The variable is N
2. The solution set would be all possible replacements for the variable N which make the sentence a true mathematical sentence. In this case only the number 3 can be considered a possible replacement. Therefore, the solution set is [3] .

A solution set may contain more than one element. This can be true, for example, when a mathematical sentence expresses the idea of inequality (greater than or less than). For instance, in the sentence 3 N is less than 16 the positive whole numbers which can be used to replace the variable N are 1,2,3,4 and 5. The solution set of positive whole number is [1,2,3,4,5] .

- 9) Get the student to try to express himself in both mathematical and spoken language. He will find it quite enjoyable to talk or write about something that he knows how to do in math. Encourage him to discuss his math with friends. This will get him to think about it more often. Many problems relate to the fact that the child is unable to read the written word of a number (seven) or symbol (plus), although he may know the figure (7) or symbol (+). Mathematics cannot be separated from oral language, writing, reading or spelling. Use vocabulary that the child can understand.

+ 7

MODERN MATH SYMBOLS AND TERMS

$+$	plus (add or find the sum)
$-$	minus (subtract or find the difference)
\times or \cdot	times (multiply or find the product)
\div	divided by (divide or find the quotient)
$=$	is equal to ($5 = 5$)
\neq	is not equal to ($5 \neq 7$)
$>$	is greater than ($7 > 5$)
$<$	is less than ($5 < 7$)
\triangle	triangle
\sphericalangle	angle
\in	is an element
\cup	union
\cap	intersect
\emptyset	no common elements (a "null" or empty set)
$\{ \}$	indicates a set, e.g. $[1,3,5,7]$

INTEGER: Any whole number, positive or negative, including 0 (zero)

POSITIVE INTEGER: A positive whole number

SET: A collection or group of elements such as numbers, letters, days, people in a family.
 $[1,3,5,7,]$ $[a,e,i,o,u,]$
 $[Monday, Wednesday, Friday]$ $[Jim, Joe, Betty]$

BRACES: $[]$ Indicates a set

ELEMENT: A member of a set. The number 7 is an element of the set $[1,5,7,]$. If we call this set B then we can state first that $B = [1,5,7,]$ and second that $7 \in B$ which means that 7 is an element of set B.

SUBSET: Elements of a set may be regrouped into subsets. A subset may contain one or all the elements of a set. The subsets of $R = [2,4,6,]$ are
 $A = [2,4,6,]$ $B = [2,4,]$ $C = [2,6]$
 $D = [4,6]$ $E = [2]$ $F = [4]$
 $G = [6]$ An empty set is a subset of every set. $H = []$.

UNION: A set of all the elements of two or more sets. For example: A union of $A = [1,3,5,]$ and $B = [2,4,6,]$ would be $C = [1,2,3,4,5,6]$ This can be expressed as $A \cup B$.

INTERSECT:

A set of all the elements common to two or more sets. For example: an intersection of $A = [a,b,c,d]$ and $B = [c,d,e,f]$ would be $C = [c,d]$. This can be expressed $A \cap B$. If there are no common elements the set is an empty or "null" set. The symbol for an empty set is \emptyset . For example: If $A = [1,6,8,]$ $B = [2,5,9]$ then $A \cap B = \emptyset$.

OPERATION:

An operation is a method of forming new sets. Union and Intersect are examples of operations.

RELATION:

A relation is a set which includes ordered pairs. An example is: $D = [(2,4) (Monday, Tuesday) (c,d)]$

DOMAIN:

A set of the first parts of the pairs. The domain of $D = [2, Monday, c]$

RANGE:

A set of the second parts of the pairs. The range of $D = [4, Tuesday, d]$

FUNCTION:

A relation with each element of the domain appearing as the first part of just one pair. For example: $E = [(a,b) (3,4) (x,y)]$

The following games and realia are useful stimulation media for tutoring math:

GAMES

1. Chess
2. Draughts
3. Backgammon
4. Dice Games
5. Checkers
6. Whist
7. Bridge
8. Cinch
9. Pinochle
10. Sixty-six
11. Hearts
12. Rummy
13. Casino
14. Solitaire
15. Cribbage
16. Poker
17. Bowling
18. On-Sets
19. Mahjong
20. Monopoly
21. Yahtze
22. Parchisi
23. Buzz
24. Simon Says
25. Shuffleboard
26. Follow the Dots
27. Lotto
28. Bingo
29. Hopscotch
30. Pencil Games
31. Darts
32. Twenty-One
33. Pick-Up Sticks
34. Baseball
35. Kickball
36. Dodgeball
37. Tennis
38. Badminton
39. Volleyball
40. Tetherball
41. Soccer
42. Field Hockey
43. Basketball
44. Golf
45. Croquet



46. Relay Games
47. Jumping Games
48. Track Events
49. Spud
50. Ice Skating
51. Swimming
52. Fishing
53. Hunting

ACTIVITIES AND SKILLS

1. Abacus
2. Map Making
3. Graphing
4. Mixing Chemical Solutions
5. Designing House Plans
6. Designing Games
7. Operating Cash Registers
8. Puzzles and "Fitting Games"
9. Stocks (Actual or Simulated Manipulation)
10. Slide Rule
11. Pedometer
12. Cooking (Measuring Cups)
13. Totaling and Estimating
14. Restaurant Tips

HOBBIES

1. Model Construction
2. Stamp Collecting
3. Erector Sets
4. Coin Collecting
5. Photography
6. Sports (Scoring, Record Keeping)
7. Number Painting
8. Collecting Historical Data
9. Collecting Match Covers, Baseball Cards, etc.

MATHEMATICS VOCABULARY DEVELOPMENT

VOCABULARY MEANINGS

1. same
2. plus
3. none
4. many
5. whole
6. part
7. minus
8. next
9. beneath
10. round
11. group
12. nickel
13. subtract
14. quarter
15. one-half
16. set
17. inch
18. feet
19. yard
20. union
21. corner
22. meter
23. centimeter
24. dozen
25. allowance
26. fare
27. one-fourth
28. high
29. wide
30. a.m. and p.m.
31. dollar
32. per
33. cash
34. C.O.D.
35. down payment
36. installment
37. annual
38. semiannual
39. depth
40. quarterly
41. tax
42. collection
43. greater than
44. less than
45. digit
46. exact
47. zero
48. add
49. circular
50. dime

51. buck
52. multiply
53. divide

DISCRIMINATIONS

1. up, down
2. in, out
3. on, off
4. big, little
5. front, back
6. right, left
7. slow, fast
8. thick, thin
9. most, least
10. light, heavy
11. first, last
12. above, below
13. short, long
14. forward, backward
15. diagonal, across
16. all, none
17. empty, full
18. narrow, wide
19. more, less
20. few, many
21. quickly, slowly
22. less than, more than
23. large, small
24. top, bottom
25. in front of, behind
26. same, different
27. expensive, cheap
28. uptown, downtown
29. higher, lower



RELATIONSHIPS

1. color of objects
2. number of objects
3. shape of objects
4. conserving numbers
5. conserving substance
6. comparing unequal sets
7. ordering size of objects
8. relating sets to sub-sets

RELATIONSHIPS
(continued)

9. "to" and "after"
(relating to time)
10. addition and multiplication
11. subtraction and division
12. hour and minute
13. second and minute
14. ounce and pound
15. inch to foot
16. pint to quart
17. nickel to dime



ABILITIES

1. add and subtract with objects
2. tell time
3. make change
4. count by rote
5. read number symbols
6. understand money values
7. use ruler for measuring
8. comprehend fractional concepts
9. add in columns
10. add two-place numbers
11. subtract
12. identify money using decimal notation
13. totaling and estimating restaurant bills
14. match time with daily activities
15. recognize number elements in a group without counting



ACTIVITIES AND GAMES

In working with children in mathematics, there are many materials and games available at your disposal that can be incorporated in with activities, such as a deck of cards, Bingo, or Bingo-type games, and checkers. Catalogs and newspaper ads can present activities that are fun. Give the child a set amount of money or a budget with which to work and have them go on a "shopping spree". This could also give them experience in filling an order blank. An activity that would be appealing, particularly to girls, would be to use recipes. This provides practical experience in fractions, in increasing and decreasing proportions of ingredients, and for science, the reactions of chemicals, heat and cold in cooking. This type of activity is a commonplace experience they will encounter in everyday living.

The application of math applies very creatively to bulletin board displays. Many nursery rhymes or seasonal displays can contain different numbers of different items or components of a figure, and children can assist in changing the designs and count as they assemble the components. A countdown at holiday times may be made on the bulletin board by having each letter of the greeting numbered from right to left, the opposite of the letters. Each day you turn one over until the holiday arrives. Flannel boards, pocket charts, posters and pictures are useful media for games and reinforcement.

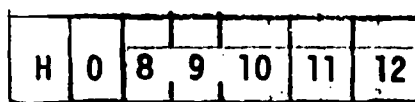

HAPPY HOLIDAYS

Buttons may be stored in decorated orange juice cans, to be used for counting and solving problems. A piece of adhesive may be attached to the top of bottle caps and numbered from 0 to 10 with a fine point felt pen, and another set made using mathematical symbols.

Large paper grocery sacks may have holes cut in the bottom and sides for child's head and arms, inverted and worn as a cape or smock. If large numbers or symbols are written on the back and front, children can be on teams and change around to make many games of the numbers.

Excellent resources for games are available in books listed in the bibliography of this manual.

The following ideas are not in any special order for grade level. Read through all of them and use the ones that you think will accomplish your goals. Each can be made more or less demanding than the form in which it is written, so they can be adapted to your particular situation.

Magic Squares

This is the basic 3 X 3 Magic square -

8	1	6
3	5	7
4	9	2

It's called Magic because no matter which way you add, up and down, across or even diagonally, you always get the same sum, namely 15.

One thing that can be done with the squares is to not fill them completely in such as -

9	2	
	6	
		3

This can be completed with just the numbers that are there. The $9 + 6 + 3$ tells you that everything adds to 18 and the 2 allows you to put a 7 in the righthand corner, etc.

Here are some more examples -

2		4
7		
6		

5		9
	6	
		7

	5	10
		3
		8

1		
6		2
5		

(need negative here)

4		2
	5	
8		

8		
13	9	
6		

18		16
		17
		12

	21	
	25	
	29	22

There is no need to stop at a 3 X 3 for we can consider -

16	3	2	13
5		11	
4	15	14	

The Magic squares can be made even more difficult by not giving as much information. Namely, if you say that this is an 18 square, see if the student can complete it.

9		
	6	
3		

Here are some variations -

16		12
	18	

30 square

3		1
-1		

zero square
(negatives needed)

		36
	30	
		12

90 square

$\frac{1}{5}$	$\frac{1}{3}$	
	$\frac{3}{5}$	

1 square
(fractions needed)

ARITHMETIC WITH ALGEBRA

A good way to accomplish some arithmetic drill is to hide it in some algebra. The way to do this is to first find a fact that the student knows. Suppose he knows that $2 + 3 = 5$. To start him off with some algebra ask him if he can put a number in the box to make the sentence $\square + 3 = 5$ true. When he puts in the 2 mark the sentence with a large T such as $\square + 3 = 5$ T. Give him a similar sentence such as $\square + 3 = 6$ or $\square + 2 = 5$. Let him mark them T. Now try a sentence such as $3 + \square = 5$ and let him both fill in the true answer and mark it true. Try some different sentences obtained by moving the box around such as $5 = 3 + \square$ etc., thereby also doing some subtraction.

In mathematics, there are generally two types of statements, true and false. Most students have only seen the true ones for they are the only statements that the teachers like to see. But false ones do exist and they have a connotation of being bad. They are not bad; they say just as much as a true statement.

False statements can sometimes be used to dispel fears of mathematics. Start with a sentence that you know the student knows the true answer for and ask him to put in a result to make it false, say

$$\boxed{3} + 1 = 2 \quad F$$

Praise the student highly for making it a correct false sentence and even let him make a large F after the sentence. See if he can make the same sentence even more false say,

$$\boxed{100} + 1 = 2 \quad F$$

That's really good. That's really false. Go through some more false statements that he knows how to do. He'll enjoy this.

You might argue that he is not learning anything by putting an incorrect answer down. But how does he know he is writing an incorrect result? He knows it is a false answer because he has eliminated the true answer.

See if he can find any sentences that are both true and false. (Are there any?)

MANY ADD

Many Add is an operation between two numbers. Although it is the same as multiplication, let the student make the connection.

Here is a way to introduce Many Add to your student. The symbol for Many Add is just \textcircled{M} . Start your student with the sequence,

$$\begin{array}{l} 2 \textcircled{M} 1 = 2 \\ 2 \textcircled{M} 2 = 2 + 2 \\ 2 \textcircled{M} 3 = 2 + 2 + 2 \\ 2 \textcircled{M} 4 = 2 + 2 + 2 + 2 \end{array}$$

Keep the sequence vertical so he can see what is happening with the left side and the right side. When you've gotten down to 4, the student should be able to take over and do even more. Let him do as many as he wants.

Go back now and add the right sides getting 2 , $2 + 2 = 4$, $2 + 2 + 2 = 6$, etc. He should also see a connection here.

Ask the student if he could do threes i.e., what is $3 \textcircled{M} 1 = \underline{\hspace{2cm}}$, $3 \textcircled{M} 2 = \underline{\hspace{2cm}}$. Again let him write some more.

When he has become adept at 2's, 3's and even perhaps 4's, ask him about $2 \textcircled{M} 3$ and $3 \textcircled{M} 2$. Are they equal? Have him try some others to see if they are equal.

Here is a difficult question. What is $\textcircled{X} \textcircled{M} 2$? Your student can perhaps answer it. What is $\textcircled{X} \textcircled{M} 3$, etc.? ($\textcircled{X} \textcircled{M} 2 = \textcircled{X} + \textcircled{X}$). ($\textcircled{X} = \text{Kiggleewig}$)

See if he can compute $(2 \textcircled{M} 3) \textcircled{M} 2 = 6 \textcircled{M} 2 = 12$

also

$$2 \textcircled{M} (3 \textcircled{M} 2) = 2 \textcircled{M} (6) = 12$$

TFHS (True False Happy Sad)

This is arithmetic through algebra and has many applications. Start with an open sentence such as:

$$\square + \square = 4$$

and ask your student to put numbers in the box to make the sentence true. Suppose he puts in a 1 and a 3. Then mark the sentence with a large "T" and also put a sad face like this:

$$\boxed{1} + \boxed{3} = 4 \quad (T, \text{☹})$$

He'll ask you what the sad face is but don't tell him. (The happy face means that both boxes have the same number in them and the sad face means that different numbers have been put in boxes.)

Ask him the same sentence again and tell him to try some other numbers. Say he puts 2 and 2. Mark it with a "T" and also a happy face like this:

$$\boxed{2} + \boxed{2} = 4 \quad (T, \text{☺})$$

Try some more sentences and get some good practice in on some skills that he needs. Let him start marking the sentence true or false. It is important that he figure out what the T, F, ☺ ☹ mean. Telling him will destroy his initiative to figure it out.

There are many variations that can be done with this. For instance:

$$\boxed{3} + \boxed{3} + \boxed{3} = 9 \quad (T, \text{☺})$$

It can even be used to a lesser degree in multiplication.

$$\boxed{1} \cdot \boxed{9} = 9 \quad (T, \text{☺})$$

$$\boxed{3} \cdot \boxed{3} = 9 \quad (T, \text{☺})$$

$$\boxed{3} + \boxed{3} = 7 \quad (F, \text{☺})$$

NUMBER SEQUENCES

Sequences can be used to practice addition, subtraction, and even multiplication. To introduce them, just give the student a few of the beginning numbers and let him find a few more. Here are some examples:

a)	2	4	6	8	10	12	14	16	...
b)	3	6	9	12	15	18	21	24	...
c)	1	1	2	3	5	8	13	21	...
d)	1	3	6	10	15	21	28	36	...
e)	1	2	4	8	16	32	64	128	...
f)	1	2	6	24	120	720	5040

RED GREEN SUBS

Many children have trouble with subtraction. The following is a flash card method of disguising it into some fun exercises. Take some blank flash cards and on the front put just red and green dots in any random order. On the back side put the difference. For example, if you had 3 red and 4 green on the front then on the back you would have one green dot. It's fun if you have more than one student for then they can hold them. By the way, 5 greens and 5 reds would yield nothing on the back.

A little variation can be had by putting colored numbers on the face rather than the back. For example, on the front put a red 4 and a green 5. On the back of course would be a green one.

Another variation is to put little arrows on each number. For example, on the front of the card put 3 \rightarrow and 5 \leftarrow . On the back is then a 2 \leftarrow .

HUBCAP, WIGGLE, AND CHEERIO

This is a fun exercise that can be used in any area of arithmetic where the student is having trouble. The whole idea behind it is to cook up some nutty operations (addition and multiplication are operations) and let the student figure out what the operation is. The nuttier the symbol is the better it will go over. Here is an example.

Introduce it like this. All of a sudden some day pop up with, "Did you know that $2 \otimes 3 = 8$?" (This reads 2 hubcap 3 equals 8). Your student will think you're a bit wierd. "Did you know that $3 \otimes 5 = 17$? Also $3 \otimes 4 = 14$? Can you tell me what $2 \otimes 5 = \underline{\quad}$?" At this point he will start wondering what you are doing and will try to find the result. Don't tell him how to do it but if he comes up with say $2 \otimes 5 = 10$ say "that's close" and correct it to 12. Keep giving him more problems until he knows how to compute them. It is important that he figure out how to compute it rather than you telling him. When he does, let him give you some extra hard problems.

Hubcap can be used quite well to explore popular concepts in the new math called commutativity, associativity and the distributive property. Ask your student if hubcap is commutative, i.e., does $X \otimes Y = Y \otimes X$? He will easily be able to draw a conclusion if he knows what hubcap does.

Another operation is wiggle, which is written as " \sim ". Here's what wiggle does. Did you know that $3 \sim 5 = 5$, $4 \sim 6 = 6$, $8 \sim 9 = 9$, $5 \sim 6 = 6$? What is $9 \sim 2 = \underline{\quad}$? Is wiggle commutative? Is wiggle associative? What is $X \sim Y = \underline{\quad}$?

Another possibility is cheerio. $5 \odot 3 = 10$, $9 \odot 2 = 13$, $10 \odot 5 = 17$, $10 \odot 16 = 28$. Ask the same questions as before.

Some other possibilities are \bigcirc apple, \star star, bottle top , etc.

Your student can undoubtedly come up with one of his own. Encourage him to think one up and let him give you some problems with his operation to see if you can figure it out.

NIM

This is an old game played by many people, with many variations. Start with a certain number of objects, such as 9 circles. Two people play and agree to cross out no more than a certain number, such as 3, at one time. The object of the game is to cross out the last circle.

For example, a game of (9,3) could go like this between two people A and B:

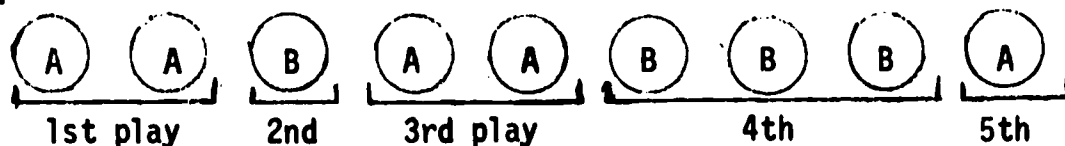

Thus A wins, since he took the last circle. Many possibilities exist, since any number of circles could be used, with the option of crossing out more or fewer than 3 circles at a time.

ALPHABET MATH GAME

List the letters of the alphabet and give a number to each letter. Give the child a word or a word list. The child determines the number for each letter and then adds up the total.

Example 4 15 7
 D 0 G 4 + 15 + 7 = 26

This could be done as a race, giving a list of words to each child. The one who completes their list first wins. This can be played with as few or as many as you wish. This also can be an exercise in spelling.

WHO AM I?

What ever number you put in one must also go in all the other 's.

is a 2 digit number.

is > 10

is < 21

is $< 2 \times 6$

is my name.

is a 1 digit number.

> 1

< 9

$> (3 \times 1) + 1$

is not an even number.

7 is not my name.

is my name.

is a 1 digit number.

> 1

< 6

is odd.

$\div 3$

is my name.

is not a multiple of 5.

< 30

is not a multiple of 4.

> 20

is an even number.

22 is not my name.

is my name.

< 10

is even number.

is a whole number.

\times =

is my name.

> 150

< 170

is a multiple of 7.

is an even number.

is not divisible by 4.

is my name.

PRIME NUMBERS

Find the prime numbers below by circling each prime:

1	②	③	4	5	6	7	8	9	10
11	12	13	14	15	16	17	18	19	20
21	22	23	24	25	26	27	28	29	30
31	32	33	34	35	36	37	38	39	40
41	42	43	44	45	46	47	48	49	50
51	52	53	54	55	56	57	58	59	60
61	62	63	64	65	66	67	68	69	70
71	72	73	74	75	76	77	78	79	80
81	82	83	84	85	86	87	88	89	90
91	92	93	94	95	96	97	98	99	100

How many primes are there less than 10?

Name the primes less than 25.

How many primes are there in the chart above?

A prime has how many factors?

Numbers that are not prime are called

Is 221 a prime number? Why?

From Los Angeles City School Volunteer Program

MULTIPLICATION

Complete each equation below:

$$3 \times 17 = 3 \times (10 + 7) = (3 \times 10) + (3 \times 7) = \square$$

$$4 \times 19 = 4 \times (10 + 9) = (4 \times 10) + (4 \times \square) = \square$$

$$5 \times 21 = 5 \times (20 + 1) = (5 \times 20) + (5 \times \square) = \square$$

$$7 \times 34 = 7 \times (30 + 4) = (7 \times 30) + (7 \times \square) = \square$$

$$6 \times 28 = 6 \times (20 + 8) = (6 \times 20) + (6 \times \square) = \square$$

$$7 \times 42 = 7 \times (40 + 2) = (\nabla \times \triangle) + (\nabla \times \square) = \square$$

$$8 \times 51 = 8 \times (50 + 1) = (\nabla \times \triangle) + (\nabla \times \square) = \square$$

$$7 \times 83 = 7 \times (80 + 3) = (\nabla \times \triangle) + (\nabla \times \square) = \square$$

$$6 \times 57 = 6 \times (50 + 7) = (\nabla \times \triangle) + (\nabla \times \square) = \square$$

$$4 \times 28 = \nabla \times (\triangle + \square) = (\nabla \times \triangle) + (\nabla \times \square) = \square$$

$$9 \times 56 = \nabla \times (\triangle + \square) = (\nabla \times \triangle) + (\nabla \times \square) = \square$$

$$8 \times 75 = \nabla \times (\triangle + \square) = (\nabla \times \triangle) + (\nabla \times \square) = \square$$

From Los Angeles City School Volunteer Program

MULTIPLICATION AND ADDITION

Do these the easy way:

$$(3 \cdot 3) + (2 \cdot 3) = \triangle \cdot 3$$

$$(4 \cdot 2) + (12 \cdot 2) = \square \cdot 2$$

$$(3 \cdot 4) + (\triangle \cdot 4) = 9 \cdot 4$$

$$(\square \cdot 5) + (10 \cdot 5) = 16 \cdot 5$$

$$(\square \cdot 7) + (24 \cdot 7) = 45 \cdot 7$$

$$(100 \cdot 3) + (200 \cdot 3) = \square \cdot 3$$

$$(111 \cdot 2) + (\square \cdot 2) = 113 \cdot 2$$

$$(149 \cdot 6) + (6 \cdot 6) = \triangle \cdot 6$$

$$(\triangle \cdot 8) + (251 \cdot 8) = 260 \cdot 8$$

$$(527 \cdot 4) + (639 \cdot 4) = \square \cdot 4$$

$$(\square \cdot 5) + (394 \cdot 5) = 412 \cdot 5$$

$$(580 \cdot 2) + (\triangle \cdot 2) = 612 \cdot 2$$

$$(6 \cdot 5) + (4 \cdot 5) = \square \cdot 5 = \triangle$$

$$(5 \cdot 7) + (14 \cdot 7) = \square \cdot 7 = \triangle$$

$$10 \cdot 8 = (\triangle \cdot 8) + (3 \cdot 8) = \triangle$$

$$\square \cdot 9 = (3 \cdot 9) + (\triangle \cdot 9) = \bigcirc$$

$$(6 \cdot 3) + (4 \cdot 3) = \triangle \cdot 3 = \square$$

$$(4 \cdot 8) + (2 \cdot 8) = \bigcirc \cdot 8 = \square$$

$$(4 \cdot 9) + (4 \cdot \square) = 4 \cdot 14 = \triangle$$

$$(7 \cdot \square) = (5 \cdot \square) + (2 \cdot \square) = \triangle$$

SUBTRACTION

	\ominus	
\downarrow $\rightarrow 8$	\downarrow 7	\downarrow 1
<hr/>		
$\rightarrow 3$	2	1
<hr/>		
$\rightarrow 5$	5	0

	\ominus	
9	2	
<hr/>		
7	1	
<hr/>		

	\ominus	
15	10	
<hr/>		
8	4	
<hr/>		

	\ominus	
25	6	
<hr/>		
10	4	
<hr/>		

	\ominus	
73	24	
<hr/>		
35	16	
<hr/>		

	\ominus	
16		6
<hr/>		
9		3
<hr/>		
	4	

	\ominus	
21		9
<hr/>		
	10	
<hr/>		
		3

	\ominus	
17	9	
<hr/>		
<hr/>		
	8	8

	\ominus	
<hr/>		
12	11	20
<hr/>		
19		10

	\ominus	
100		
<hr/>		
	25	
<hr/>		
25		25

	\ominus	
63		43
<hr/>		
20	6	
<hr/>		
	14	

	\ominus	
<hr/>		
50	50	
<hr/>		
	0	0

DIFFERENT WAYS TO ADD

⊕

3	4	7
7	6	13
10	10	20

⊕

8	3	
4	9	

⊕

10	12	
14	20	

⊕

9	15	
7	16	

⊕

6		9
	14	
20		

⊕

25		36
	12	
		63

⊕

18		25
14		
		96

⊕

19		38
	25	
47		91

⊕

	16	
20		89
90		

⊕

17		43
	16	
46		

⊕

	48	75
27	64	

⊕

	14	
19		76
		150

From Los Angeles City School Volunteer Program

FIND THE SUM

Find the sums in each of the following charts:

	0	1	3	2	9
6					
1					
2					
3					
7					

	6	4	5	8	7
6					
1					
2					
3					
7					

	0	1	3	2	9
4					
8					
9					
0					
5					

	6	4	5	8	7
4					
8					
9					
0					
5					

From Los Angeles City School Volunteer Program

ADDITION

Add in different directions:

			+		
→	9	6	7	2	4
→	3	2	1	8	7
→	12				

	↓	↓	↓	+	↓	↓
	5	9	7	8	3	
	2	1	6	4	11	

					+
	7	3	15	29	145
	5	10	16	17	13
					206

					+
	59	76	89	78	57
	41	39	19	28	52

	↓	↓	+	↓	↓
→	0	4	8		
→	9	8	7		
→	6	3	1		

				+
	3		9	27
	15		16	
	16	19		44
		43		111

				+
	21	36	28	
		62		102
	37		54	203
	63			

From Los Angeles City School Volunteer Program

RENAMING

Complete each equation:

$$70 + 12 = \square + 2$$

$$30 + 17 = \square + 7$$

$$80 + 19 = \square + 9$$

$$70 + 11 = 80 + \square$$

$$20 + 18 = 30 + \square$$

$$50 + 14 = \square + 4$$

$$30 + 12 = \square + \triangle$$

$$40 + 17 = \square + \triangle$$

$$60 + 17 = \square + \triangle$$

$$40 + 13 = \square + \triangle$$

$$30 + 16 = \square + \triangle$$

$$50 + 13 = \square + \triangle$$

$$90 + 15 = \square + \triangle$$

$$80 + 11 = \square + \triangle$$

$$70 + 10 = \square + \triangle$$

$$60 + 18 = \square + \triangle$$

$$20 + 18 = \square + \triangle$$

$$10 + 13 = \square + \triangle$$

$$30 + 12 = \square + \triangle$$

$$50 + 17 = \square + \triangle$$

$$60 + 19 = \square + \triangle$$

$$70 + 11 = \square + \triangle$$

$$80 + 14 = \square + \triangle$$

$$20 + 13 = \square + \triangle$$

NUMBER LINES

Use the number line to work out each equation:

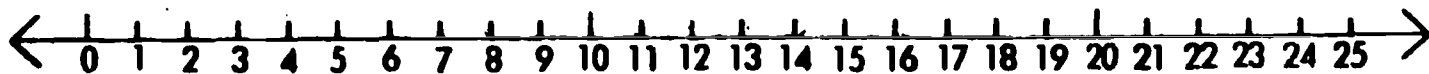

$$7 + 9 = \square$$

$$5 + \square = 21$$

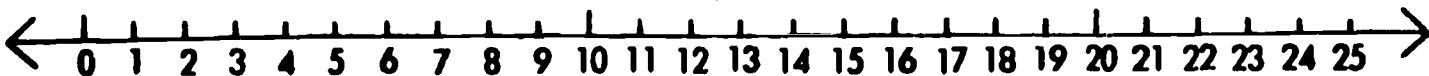

$$20 - \square = 9$$

$$\square + 13 = 24$$

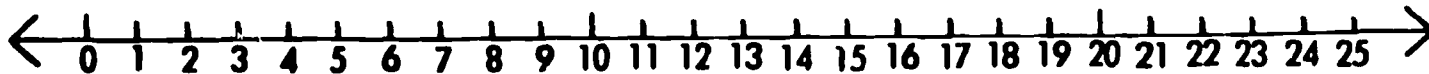

$$\square + 13 = 24$$

$$\square - 9 = 13$$

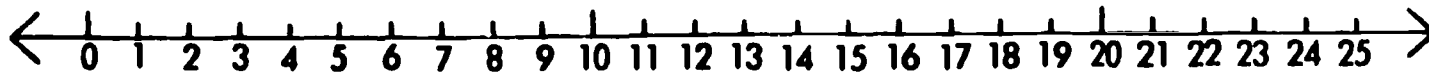

$$9 + \square = 21$$

$$12 + 15 = \square$$



$$27 + 21 = \square$$

$$\square + 19 = 47$$

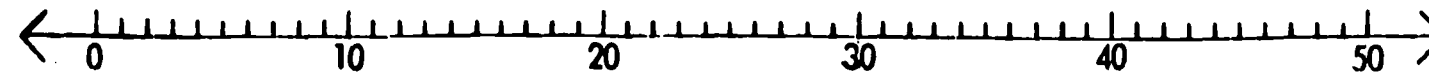

$$\square - 17 = 36$$

$$37 - \square = 37$$



$$25 + \square = 49$$

$$26 + \square = 52$$

From Los Angeles City School Volunteer Program

EXPANDED NOTATION

Write in the correct answer in the spaces provided:

$$35 = (3 \times 10) + (5 \times 1) = 30 + 5$$

$$17 = (\quad) + (\quad) = \underline{\quad} + \underline{\quad}$$

$$43 = (\quad) + (\quad) = \underline{\quad} + \underline{\quad}$$

$$67 = (\quad) + (\quad) = \underline{\quad} + \underline{\quad}$$

$$93 = (\quad) + (\quad) = \underline{\quad} + \underline{\quad}$$

$$101 = (\quad) + (\quad) + (\quad) = \underline{\quad} + \underline{\quad} + \underline{\quad}$$

$$236 = (\quad) + (\quad) + (\quad) = \underline{\quad} + \underline{\quad} + \underline{\quad}$$

$$473 = (\quad) + (\quad) + (\quad) = \underline{\quad} + \underline{\quad} + \underline{\quad}$$

$$560 = (\quad) + (\quad) + (\quad) = \underline{\quad} + \underline{\quad} + \underline{\quad}$$

$$875 = (\quad) + (\quad) + (\quad) = \underline{\quad} + \underline{\quad} + \underline{\quad}$$

$$759 = (\quad) + (\quad) + (\quad) = \underline{\quad} + \underline{\quad} + \underline{\quad}$$

$$987 = (\quad) + (\quad) + (\quad) = \underline{\quad} + \underline{\quad} + \underline{\quad}$$

From Los Angeles City School Volunteer Program

FIND THE PRODUCTS

Find the products of the factors shown below:

	0	1	3	2	9
6					
1					
2					
3					
7					

	6	4	5	8	7
6					
1					
2					
3					
7					

	0	1	3	2	9
4					
8					
9					
0					
5					

	6	4	5	8	7
4					
8					
9					
0					
5					

From Los Angeles City School Volunteer Program

MATH COLORING GAME

DIRECTIONS: FIND THE PARTNER NUMBERS IN EACH BOX, AND COLOR THEM THE SAME COLOR. MAKE ONE 1 ONE COLOR, 2 TWO ANOTHER COLOR, ETC.

Visual Discrimination - Geometry

Attach to the easel a paper with the following diagram shown:

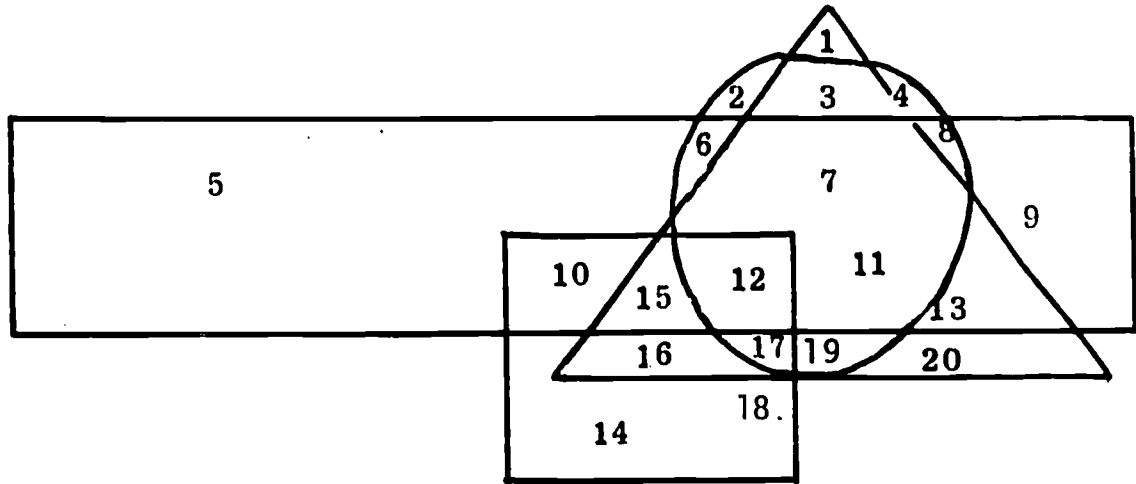

Have the following questions on a card:

What numerals are:

1. In the rectangle, but not in the circle, square, or triangle? (5,9)
2. In the triangle, but not in the rectangle or square? (20,19,3,1)
3. In the square, but not in the circle or triangle? (10,14)
4. In the circle, but not in the triangle or rectangle? (15,2,4)
5. In the rectangle, but not in the triangle or square? (5,6,8,9)
6. In the square, but not in the rectangle or circle? (14,16,18)
7. In the triangle, but not in the circle or square? (20,13,1)

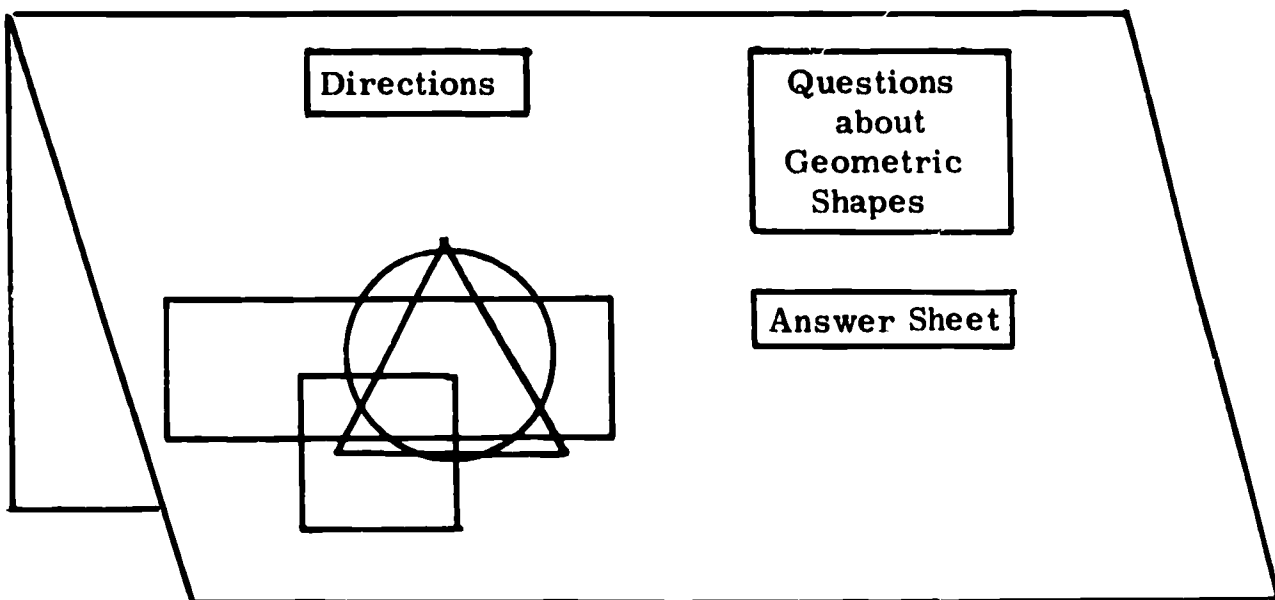

From Board of Education, Prince George's County, Upper Marlboro, Maryland

Visual Discrimination of Numerals

Directions:

1. Take the cards from the pocket. Notice that each card has a pair of numerals. On some cards the pairs are alike; on other cards they are different.
2. If the pair is alike, put the cards in the correct pocket. Do the same thing for the cards that have different pairs.
3. Check your work using the answer sheet.

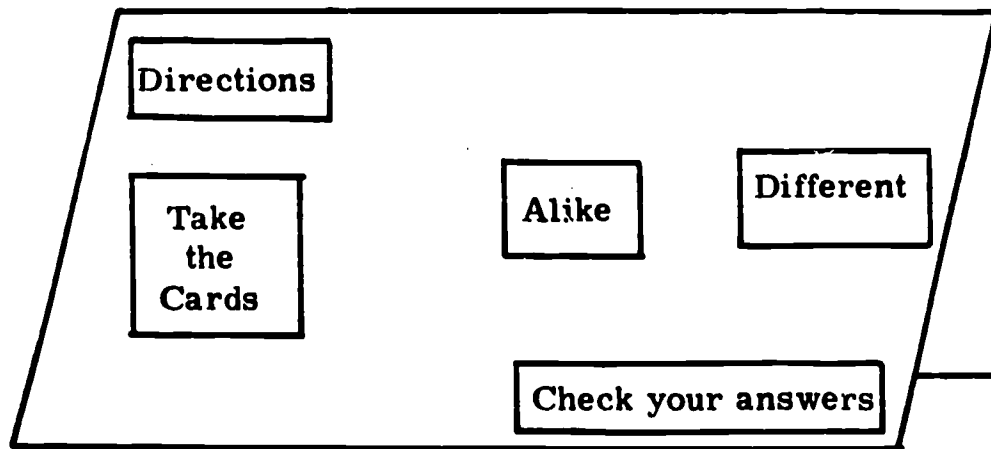

EXAMPLE: (Grades 2-3)

- | | | | | | | | |
|-----|-----|---|-----|-----|-------|---|-------|
| 1. | 43 | - | 43 | 11. | 101 | - | 110 |
| 2. | 39 | - | 93 | 12. | 231 | - | 231 |
| 3. | 66 | - | 66 | 13. | 456 | - | 465 |
| 4. | 583 | - | 538 | 14. | 8668 | - | 8668 |
| 5. | 36 | - | 63 | 15. | 4513 | - | 5413 |
| 6. | 502 | - | 502 | 16. | 279 | - | 279 |
| 7. | 97 | - | 97 | 17. | 1121 | - | 1211 |
| 8. | 522 | - | 532 | 18. | 3289 | - | 3289 |
| 9. | 988 | - | 898 | 19. | 1045 | - | 1405 |
| 10. | 45 | - | 44 | 20. | 65336 | - | 65336 |

EXAMPLE: (Grades 4-6)

- | | | | | | | | |
|-----|--------|---|--------|-----|------------|---|-----------|
| 1. | 245 | - | 245 | 11. | 2198447 | - | 2198447 |
| 2. | 869 | - | 896 | 12. | 3655543 | - | 365543 |
| 3. | 4486 | - | 4486 | 13. | 9712865 | - | 9713865 |
| 4. | 46894 | - | 46984 | 14. | 4281437 | - | 4821437 |
| 5. | 32815 | - | 32615 | 15. | 670413822 | - | 670143822 |
| 6. | 678543 | - | 678543 | 16. | 5868845 | - | 5968845 |
| 7. | 201859 | - | 201589 | 17. | 4580066392 | - | 458006392 |
| 8. | 831169 | - | 831169 | 18. | 768145 | - | 768145 |
| 9. | 187543 | - | 187543 | 19. | 418853321 | - | 41885321 |
| 10. | 853214 | - | 853414 | 20. | 98532 | - | 98532 |

From Board of Education, Prince George's County, Upper Marlboro, Maryland



Draw a line from number 1 to number 79, to complete this picture.

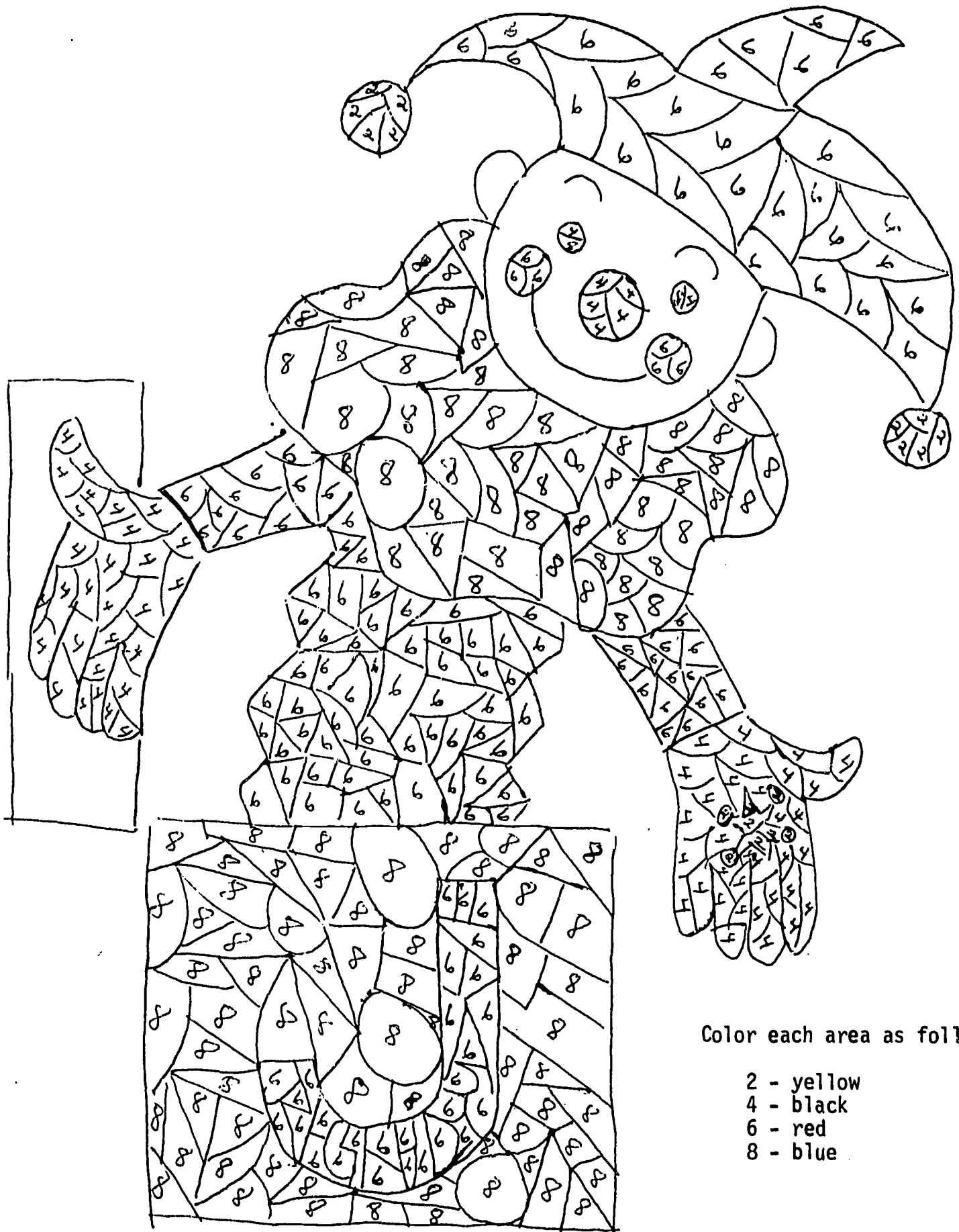

Color each area as follows:

- 2 - yellow
- 4 - black
- 6 - red
- 8 - blue

NUMBER PUZZLE

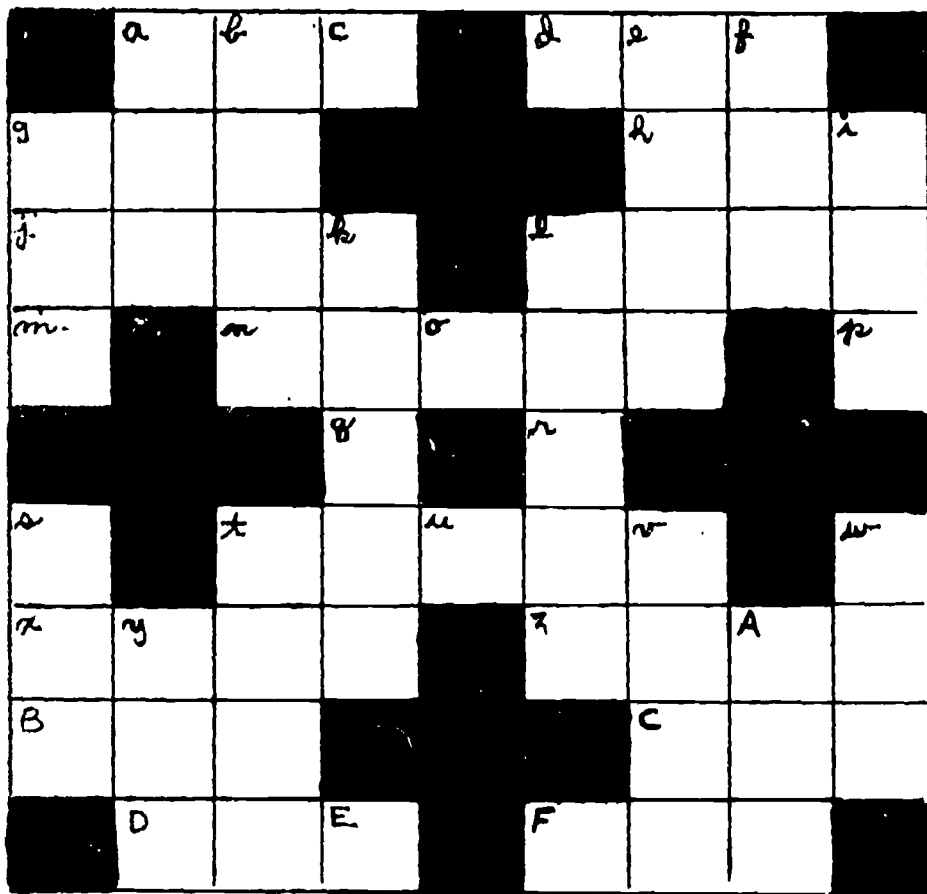

ACROSS

- a - first three odd numbers
- d - first three even numbers
- g - $248 \div 2 =$
- h - $147 \times 3 =$
- j - $511 \times 5 =$
- l - 1111 doubled =
- m - no number
- n - count backward from 6
- p - $12 - 10 =$
- q - square root of 9 =
- r - 2 squared =
- s - $10 - 3 =$
- t - $(100 \times 10) + 555 =$
- w - 3 squared =
- x - $44 \times 100 =$
- z - $(1,000 \times 6) + 666 =$
- B - number sequence starting with the number 1
- C - $111 \times 3 =$
- D - 10 squared + square root of 25 =
- F - 12 squared =

DOWN

- a - $100 + 25 =$
- b - number sequence starting with 3
- c - $3 + 2 =$
- d - square root of 4 =
- e - $1108 \times 4 =$
- f - starting with 6 - count backward by 2
- g - $95 + 25 =$
- i - $135 - 13 =$
- k - $553 \times 100 =$
- l - number sequence starting with 2
- o - square root of 16 =
- s - starting with 7, count backwards by 3
- t - 10 squared + 30 =
- u - square root of 25 =
- v - 75 squared + 9 =
- w - starting with 9, count backwards by 3
- y - $(75 \times 6) - 29 =$
- A - $550 + 84 =$
- E - $23 - 18 =$
- F - 1 squared =

INTEREST INVENTORY

After school I like to _____

My favorite television programs are _____

My favorite game is _____

The subject I like best in school is _____

My favorite sport is _____

My hobby is _____

I have _____ brothers and sisters. Their ages are _____

Circle the word that describes how much you like the activity.

	DON'T LIKE	LIKE A LITTLE	LIKE A LOT
grocery shop	_____	_____	_____
cut and paste	_____	_____	_____
an allowance	_____	_____	_____
tell time	_____	_____	_____
keep baseball scores	_____	_____	_____
paint by numbers	_____	_____	_____
cook	_____	_____	_____
read maps	_____	_____	_____
build models	_____	_____	_____
draw shapes and figures	_____	_____	_____
do puzzles	_____	_____	_____
count money	_____	_____	_____

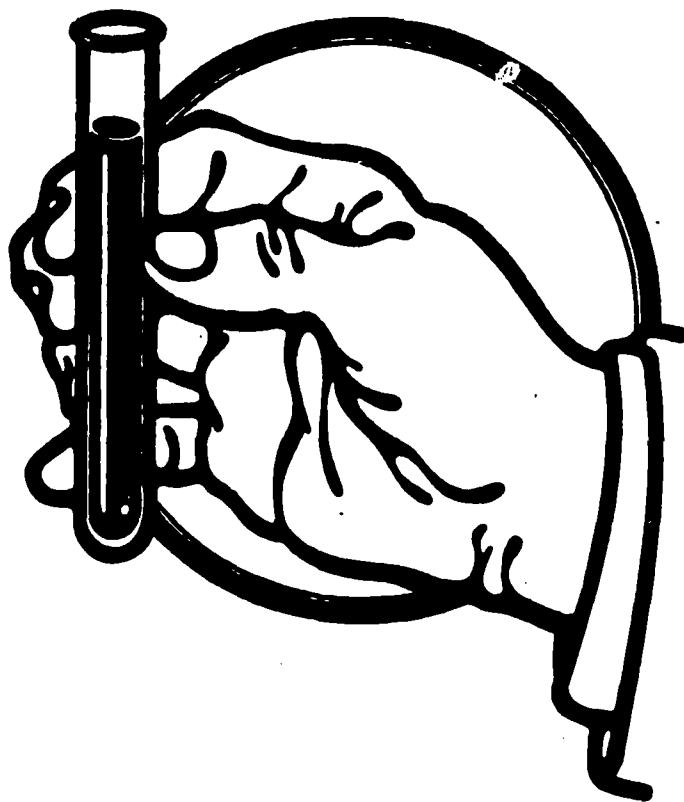

CHAPTER FIVE

APPLICATION OF MEDIA TO SCIENCE TUTORING

TUTORING TIPS AND TECHNIQUES

Science is of tremendous significance in this day and age; never has our world been more technological and complicated. It is of small wonder that our children are constantly inquiring into the "how" and "why" of the world about them. This, in essence, from their first simple questions, is the introduction to their lifelong encounter with the world of science.

As a child starts school, his experiences begin to mold his life, and hopefully add new dimensions. It is the responsibility of the teacher, with the assistance of volunteers and parents, to encourage and nurture the natural curiosity that will lead to the understanding and appreciation of the study of science.

Games and experiments in science can show children how the study subject actually works. Once the classroom teacher has presented the material, then the tutor can work on an individualized basis with the child. The use of experiments and games could bring about as the end result, a less frustrated child, and a more relaxed, happy classroom for both students and teachers.

No two children are alike. They learn in different ways and at different speeds. This is why an individualized experience with a tutor can be extremely beneficial. However, it should always be kept in mind that the teacher is of the utmost importance. The teacher is the person who helps the child to discover facts, to become resourceful, and develop the confidence needed to become inquisitive and self-reliant. The basis of science is investigation. The volunteer can be a guide to help the child find the answers, but a good volunteer will not give the child the answer he wants, but assist him in ways of finding solutions. It is in this method that the volunteer tutor becomes important as he can give the individualized attention to reinforce the basic work the teacher has previously laid.

Science is not a means unto itself. A student must understand mathematics and reading. There will be times that the tutor may also need to assist and reinforce in these areas, before the child can attempt to understand science. Often an experiment in science calls for the use of mathematical computation and reasoning. Since children must have the ability to read in any subject they study, good reading is self-explanatory as to its importance in science. Science in turn can be helpful to the child who has a problem in reading. If a child is interested in a specific science area, he should be encouraged to use books and materials that would enhance his interest, improve his reading skills, and also help him to acquire more knowledge in that particular subject area.

Safety must always be stressed. One small accident could completely undo all the work that has been done previously. This is especially true in the area of experimentation. As you can readily observe, the volunteer can be helpful in seeing that caution is taken, and good safety habits are enforced.

In the tutoring of science, there are three concepts to keep in mind. These are Principles, Inquiry, and Creativity. Let us examine each individually.

1. Principles - The discovery of principles comes about through experimentation and investigation, either in the laboratory periods in school or through field trips.
2. Inquiry - Inquiry is extremely important in the process of discovery. The study of science would be unsuccessful without this component, which is developed through study, investigation and problem solving activities.
3. Creativity - Each child needs to be encouraged to develop his own talents. Open ended activities permits the child to move at his own particular pace, and thus through study, exploration, observation, and experimentation, develop his ability to create. Each child's level of creativity is different, and the tutor should keep in mind that there will be a deviance which should be taken into consideration. It is important to motivate a child to create, and to bring out all the inherent talents. The volunteer should also be aware of the limitations of a child, and not attempt to push beyond these limitations, as this could only frustrate the child, and perhaps "turn him off" completely.

It could be helpful to the volunteer working on a one to one basis with a child, to find out his particular interest within the broad topic of science. In starting to work with a child, you will build up a greater rapport with him if you start with his special interests. An example of an interest finder can be found at the end of the chapter.

Several areas of learning in science have previously been mentioned. Let us now look, in more detail, at these particular areas. It is important that the volunteer know and understand these so he can be more effective as a tutor.

1. Experimentation - Experimentation is used to help find a solution to a problem. This should be accompanied by both reading and discussion. Experiments should never be considered as a means of entertainment. The primary purpose is to clarify an idea or concept, and to satisfy the child's curiosity. Careful planning must be done. It is wise that the teacher and the tutor work together in this phase. There are four major parts to an experiment -

question
experimental procedure
results
conclusion



Experimentation is undoubtedly the most important learning technique in science. This approach can give vitality, meaning, and reality to the program.

2. Research - The greatest share of research for science information will be through reading. Not only should a child read his text or workbook, but he also should be encouraged to read as much supplementary material as he can. Reliable data often needed for experimentation and discussion is only acquired through research in reading. This research can also substantiate information gleaned from other sources. It is important that the authenticity and currentness of the sources of material be reliable. Remember newspapers and magazines can also be sources of information. There are times that through research a child will develop a deep interest in a particular subject. Because of this, a hobby might be acquired or the child might be inspired to adopting an avocation or perhaps his life's vocation in this field.
3. Construction - Models are an excellent example of construction activities, and can serve a valuable purpose. Very careful advanced study should be done in preparation. A model can be made either larger or smaller, or even of the same size as its realistic counterpart. Many different topics can be used, including animals and planets. Relief maps, machines of different types, and puppets are just a few examples of the types of models that an elementary student can make. Children will develop a sense of achievement once they have made a model of something that actually works. A tutor can be helpful to assist a child who is having problems in constructing a model of some type, and perhaps secure materials for the project. The feeling of success this child hopefully will achieve could help to bring about a change in his self-perception, and could be a turning point in his educational pattern. Many slow learning children can become extremely capable with the use of their hands, and this could give some the opportunity to reveal their mechanical skills.
4. Field Trip - The field trip plays an important role for elementary children, and is a form of activity that children anticipate and enjoy. There are many types of field trips, ranging from the study of nature trails to a visit to the local dairy or telephone company. Volunteer's assistance is almost a necessity for the teacher on these outings. The tutor can work with the child both before and after the trip, so that the experience he encounters will be more meaningful to him. Careful advance planning is necessary to make the trip a success. The children should be primed for particulars they can observe. If this is done, the academic work within the classroom will take on more interest and meaning. Many films or film strips may be used to supplement the visit.
5. Audio-visual Instruction - All of the educational multi-media previously discussed are excellent variations in the presentation of science materials. They can lend variety to the presentation of materials and thus create new interest for the children. If interest is not there, the learning process becomes much more difficult, if not impossible. Allowing children to prepare a bulletin board on a subject they are studying not only can be a source of enjoyment and creativity, but also a learning process.

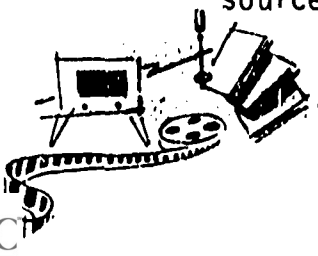

6. Community Resources - The decades of the 1960's and 1970's are the only times when we shall have living testimony, ranging from youngsters who have witnessed on television, man walking in space and on the moon, to our senior citizens, who lived in sod houses, traveled without benefit of mechanization, and produced food, clothing, and other necessities of life from raw materials, step by step to the finished product. Canned and frozen foods, ready-made garments (many of man-made fibers) and electrical gadgets to clean, heat and cool homes were unknown to them. In many parts of our country, these pioneers are being asked to record this "living history" and to serve as resource volunteers. An excellent example of this type of a volunteer program is in the Chicago Model Cities area. The program is called "Living History and Heritage" and is sponsored by the senior citizens division of the Department of Human Resources. The volunteers are all retired school teachers from the Chicago area who are going into the schools and giving firsthand accounts to the children as to what life was like before automobiles, radios, telephones, and TV. Other types of community resources could include a specialist in a particular field of study, and those who have traveled to, or come from countries that relate to a particular unit under study. The students' interest will increase and the topic will take on importance as the resource person can give firsthand information to the subject being studied. Not only are the resource volunteers giving a contribution of knowledge to the students, but they are also creating good will between community and the school.

Other types of activities in which a volunteer or tutor may assist the classroom teacher could be in role play, panel discussions, dialogues, dramatizations, buzz sessions and art work. Many of these could be considered an enrichment activity, but relate to many fields of science. These types of learning techniques could motivate a bright child into probing for more information, where otherwise he might be "turned off" as he becomes bored while "waiting" for the rest of the class.

In the handbook for tutoring elementary pupils, "How Can I Help Children Investigate Science?", as developed by the Los Angeles School Volunteer Program, the following statements are made.

"When you tutor in the field of science, you will need to understand that it is more than simply a body of knowledge. Science is also a way of thinking and working. Teaching pupils how to think is one of the important purposes of today's school science program. Science not only introduces the pupil to a field of vital importance but also to ways of learning and discovering new information and ideas.

"Children have special characteristics which need to be considered as they study science. Like the scientist who continually searches for truth, the child always wants to know. He asks questions, explores, and investigates to find answer. The tutor can play a very important role by involving the pupil in questioning, wondering, searching for answers, discovering, and developing enthusiasm.

"Learning about the world of science can be a real adventure for you and your pupil. The science program in the elementary school capitalizes on the child's natural curiosity and desire to explore the world around him."

Besides tutoring, volunteers can be useful in science as teachers' aides, and as clerical, lab, and field trip assistants. It is hopeful that volunteers will respond to the classroom teachers' needs and desires, whether it is tutoring or in some other volunteer capacity.

HOW CAN THE STUDY OF SCIENCE IMPROVE BASIC SKILLS?

When your pupil investigates science problems, he will need to use basic skills from other subject areas, such as reading, oral and written language, and mathematics. The tutor should help the child understand the relationship between science and these other fields of study. Often, the strong motivation and interest that the study of science stimulates will help pupils to improve their skills in other subject areas.

Help the Pupil to Use Oral and Written English in Science

One of the important purposes of tutoring is to help young people develop communication or language skills. Purposes include development of a useful and descriptive vocabulary, correct use of words to express ideas, writing about observations and findings, learning to spell certain words, and reading about related work done by other persons. The tutor should use precise and descriptive words in discussing a science activity as it is being performed, and he should encourage the pupil to describe what he has accomplished. The tutor may want to record the pupil's story and use it to teach his pupil to read and spell certain words which he now understands and uses with confidence. Help the child to phrase questions that can be answered by further experimentation and keep a written record of the results. Afterward, the pupil may be ready to read about similar experiments as described in textbooks or library books.

Help the Pupil to Use Mathematics in Science

Many explorations in science lend themselves to teaching mathematical ideas. Things need to be counted, numbers need to be compared, and quantities need to be measured. For instance, how many paper clips will the child's magnet pick up? Do two magnets attract more paper clips when used together or separately? How could you use paper clips to devise a measuring system to determine the strength of magnets? From how far away will the magnet attract a paper clip? Help the child to use the skills of mathematics to express relationships, develop simple bar and line graphs, and predict what will happen in different situations, based on information which has been gathered.

Encourage the Pupil to Investigate Science Problems at Home

The tutor should plan activities that will help the pupil to develop skills needed for investigation. Between periods of instruction the child should be able to continue the science activities at home in his free time. He can find related examples of the events which he has observed, repeat experiments to determine whether he obtains the same results, and repeats experiments using different materials. He may continue making measurements and testing in other situations, write a paragraph about his science study, or read a book from the library. These activities should be planned to sustain progress during tutoring sessions.

Following are safety practices and some activities, experiments and games that could assist and make the subject of science more meaningful. Although play should not be the only activity, it is important that not all work should be distasteful. There is a distinct difference between play and entertainment. These types of activities should definitely not be overlooked for motivation and learning. Play is considered the true language of children, and teachers and tutors should capitalize on this language.

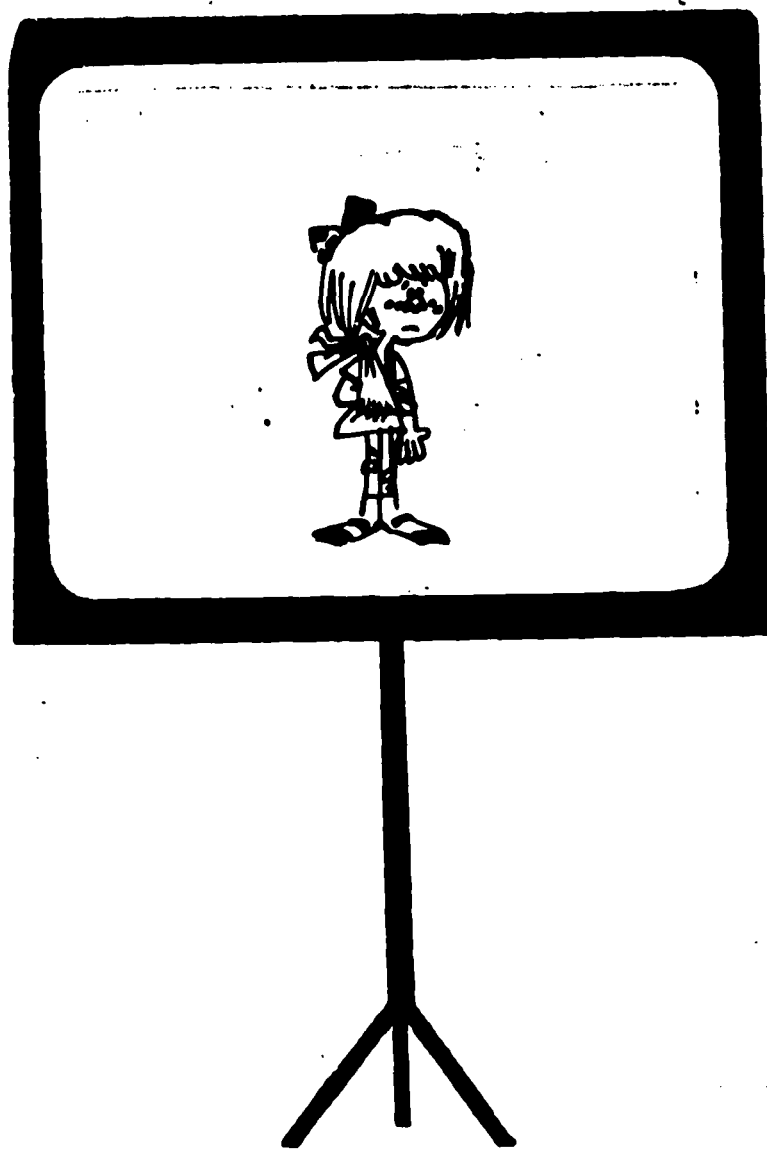

POT LUCK: An exhibit in a school science fair, entered by a 2nd grader, consisted of a red flower pot, scrubbed clean and filled with rich-looking soil. Attached to it was a painfully printed explanation: "Some seeds don't grow."



Taken from November, VIP Newsletter, St. Paul Public Schools, St. Paul, Minnesota

WHAT ARE SOME SUGGESTED SAFETY PRACTICES?¹

In performing experiments and demonstrations involving science materials, the tutor and pupil must recognize the importance of safety precautions in the handling of materials and equipment. Accidents can be prevented when the tutor and pupil follow directions and observe precautions. The following safety practices are presented as a guide for science tutors:

General Information

The tutor should:

1. Be aware of any safety hazard that develops in a room, such as defective electric outlets and connections.
2. Try out an experiment before it is performed by the pupil.
3. Perform demonstrations far enough away from the pupil so that he will not be injured in case of accident.
4. Supervise the pupil carefully when he is using sharp-edged instruments.
5. Caution the child not to attempt any experiments involving the use of matches, open flame, or electricity when he is alone.
6. Discuss location of fire-fighting apparatus at home and school.

Using Electricity

The tutor should:

1. Use only dry cells or school approved transformers when conducting experiments involving electric current.
2. Use only insulated wire in experiments involving electrical "set-ups". The child should be closely supervised when removing insulation from wire.
3. Make the pupil aware of the hazard involved in "short circuiting" dry cell or storage batteries.
4. Caution the child not to touch electrical equipment immediately after it has been used. Most electrical devices are hot after use.
5. Examine all electrical "set-ups" before they are used by children.

Using Heat

The tutor should:

1. Demonstrate experiments involving boiling water. The child should remain a minimum of three feet away from experiments requiring boiling water.
2. Never permit the child to handle or carry containers with boiling water.

¹ "How Can I Help Children Investigate Science?" A Handbook for Tutoring Elementary Pupils, Los Angeles City Schools, SCHOOL VOLUNTEER PROGRAM, 450 N. Grand Avenue-Room G-372, Los Angeles, California 90012, p. 12-14.

Using Heat

3. Use only electric hot plates furnished by the school. When these are not available, it is permissible to use an electric hot plate which is stamped with an Underwriter's laboratory approval. Such hot plates, if not self-insulated, should be placed on a fire-resistive surface (such as wood of at least one-half inch thickness).
4. Perform all experiments requiring the use of an open flame with candles or canned heat. The use of propane, butane, or Prest-O-Lite is prohibited.
5. Never perform any experiments involving the heating of alcohol, hydrocarbons, strong acids, or strong bases.
6. Never heat a completely stoppered container.

Using Chemicals

The tutor should:

1. Never perform demonstrations involving explosive materials, strong acids, or strong bases.
2. Never mix chemicals to "see what happens".
3. Never use dry ice.
4. Caution the child about using chemicals at home.

Caring for Animals

The tutor should:

1. Be thoroughly familiar with the proper care of animals used for study.
2. Teach the child proper methods of handling pets and other animals.
3. Caution the child not to disturb animals while they are feeding.
4. Notify the principal, nurse, or parent immediately if a pupil is bitten by an animal; so the child's doctor and health department may be notified.
5. Caution the child against bringing poisonous insects or other living things into the classroom.

Using Glass

The tutor should:

1. See to it that the raw edges of glass plates are bound with adhesive, masking, or cellophane tape.
2. Make certain that glass bowls and magnifying lenses are not left in strong sunlight.
3. Caution the child not to cut nor improperly manipulate glass tubing. The pupil may use glass tubing only when he has received precautionary instructions from the tutor.

Using Glass

4. Caution the child to use water, soap, or glycerine as a lubricant before forcing glass tubing into rubber stoppers. Be sure that tubing always is directed away from the palm of the hand which holds the stopper or rubber tubing.
5. Direct the child always to hold glass tubing as close as possible to the part where it is entering the rubber stopper. A cloth wrapped around the hand or tubing at the point of contact with the hand will help avoid injury if the glass breaks.
6. Use pyrex glass containers at all times.

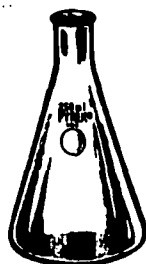

RESOURCES

Contact the nearest local or state source of the following:

American Cancer Society - literature

American Heart Association - literature, models and charts available

American Red Cross - first aid materials

City Greenhouse

Conservation Commission

Councils on Alcohol and Drug Problems

Dairy Council - materials on health and nutrition

Department of Education

Environmental and Ecology Organizations

Florist Association

Food Industry Council

Health Department

Isaac Walton League - nature and wild-life materials

Medical and Pharmaceutical Associations

Museums

Science Center

Telephone Company

Tuberculosis and Respiratory Disease Association - literature

Weather Bureau

Zoos



ACTIVITIES AND GAMES

ACTIVITIES

Experiment with Air

Place a small cloth in the bottom of a large glass. Turn the glass upside down and push it straight down into a container of water. Remove the glass from the water and the cloth from the glass. The cloth will be dry, showing that air takes up space and will not allow water into the glass.

Drinking Straw with Water

Place water in the straw and hold finger over the top. The water will not run out as the air keeps it from doing so. Take your finger from the top of the straw and the water will run as the air goes into the top of the straw. Air will push in all directions.

Making a Siphon

Pinch the ends of a tube so that no air can get in the tube. Place one end in a pan of water, then the other in an empty pan, making sure the empty pan is on a lower level. Water should run from the one pan to another. If this experiment does not work, either air was still in the tube or the empty container was not lower than the other.

Making a Weather Vane

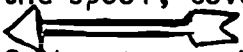
Materials needed: a spool, scotch tape, a drinking straw and construction paper, and a hat pin. Place the drinking straw in the spool, covering the end of the spool with scotch tape - cut an arrow () from the construction paper and pin it to the top of the straw. When finished the weather vane will point in the direction the wind is blowing.

Magnets

Place a paper clip on top of a piece of glass. Put the magnet under the glass. By tilting the glass and dragging the magnet from the underside, you can make the paper clip "walk" up the glass.

Water

Drop different articles such as coins, hairpins, bits of paper, or a pebble in a container of water. Which articles sink and which float? Those articles heavier than water will sink to the bottom, while those that float are lighter.

Sound

Place a watch on a table, and stand twelve inches from table. Next lay your head on the table, still 12" from the watch. Which sounds louder? This proves that sound travels better through wood than air.

Making a Telephone

Make holes in the bottom of two empty tin cans. Put a long string through the cans and tie knots in the end of the string to hold them in the can. Rub wax on the string. Each person takes a can and moves away from each other until the string is taut. One person talks in the end of the can and the other places it to his ear. The sound waves travel along the string from the one can to the other.

Experiments with an Overhead Projector

1. Place different objects on the projector such as an ash tray, jewelry, lead glass, water in a glass container, and see the different designs and patterns made from the light. Add color acetates for different effects.
(The Grade Teacher - December 1971)
2. Use the overhead projector for class to identify different plants and flowers. These can be made with transparencies. Additional parts of the flower, for instance, could be done with overlays, to identify the many parts of the plant or flower. This could also be done with many other things when you wish to identify the different parts. Once these transparencies are completed, they can be used over and over again.

Dish Garden

Materials needed: a square or oblong cake pan, a pie plate, or a foam meat tray, cotton batting, various size rocks or stones, grass seed. Children can collect the rocks, but must keep in mind the size of the dish they are using. Wash the stones. Cover the bottom of the dish with the cotton. Some of the larger stones could also be covered to make hills. Make sure the cotton is thick enough to hold moisture. Thoroughly moisten the cotton with lukewarm water. Sprinkle the grass seed over the top of the cotton and then cover with a very thin layer of cotton fibers. Leave just enough to retain moisture, but thin enough for grass seed to come through. Covering the dish with clear thin plastic helps to retain the moisture, if it must be left unattended for a few days. Grass should start to germinate in three days, and should be grown in ten.

Where Do I Belong

Label different boxes such as animals, plants, insects, elements, etc. Put a slot in the top of the boxes. Paste pictures or write words on cards that would fit into the different categories. As a child has free time, they can place the cards in the correct box.

Touch

Object Hunt - Take children on a walk, to a playground, or to a park. Give each a sack to collect objects that will fit in the sack. After they return to the classroom, they then categorize the objects as to long, short, hard, soft, smooth, rough, sharp, dull, etc. This also can be done with articles collected around the classroom, or brought from home, and then be classified as to the substance of which they are made. This is an example for the awareness of the sense of touch.

Sound



Records or Tapes - Have children listen to records or tapes made from different sounds and have them attempt to simulate and identify the sounds. They could be categorized as city and country noises, loud and soft, pleasant or unpleasant, etc.

Musical Glasses - Place water tumblers on a table and by adjusting the water level in the glasses, a musical scale can be made. The children then can either make up or play simple tunes by tapping the glasses with a metal object such as a spoon.

Sound

Science Sound Log - Make a chart of different descriptive words. Help children collect pictures that depict that sound to them. Have them paste the picture next to the word, then write how the sound "sounds" to them and their conclusion as to where it would be found.

Example -

Science Sound Log			
Word	Picture	Impression	Conclusion
Cry		Unhappy	Home
Whistle		Shrill	Kitchen

Science Box

In a heavy cardboard box, place measuring devices, scissors, small tools, foil, jars, switches, batteries, bulbs, and any other equipment that could be helpful for individual activities or experiments. As a child finishes with homework and is looking for something to do, this can keep him busy in creating his own experiment.

Movie Machine

Materials needed: wooden crate or grocery carton, two equal lengths of a broomstick or a dowel rod, and plain shelf paper. Place the box on its side and cut an oblong hole in the bottom. Next cut holes in the top just on the outer edge of the "picture" hole. Take the shelf paper and draw or paste the pictures for the movie on this. Next roll the "movie" around the rod which has been placed in the hole at the top of the box. Attach the paper to the rod with thumbtacks or scotch tape, pull across and attach to the other rod. The movie is produced by rolling it from one rod to the other.

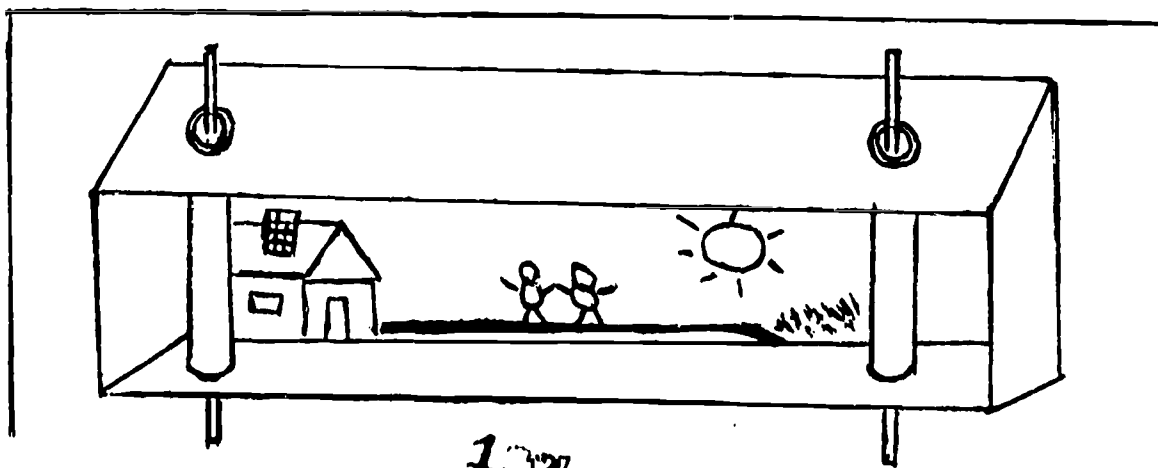

Making Dew

Materials: tin cup, salt, and ice. **Directions:** Fill the cup with ice and water and add the salt to the water gradually. Drops of water will form on the outside of the cup. Cold air cannot hold as much water vapor as hot air can, therefore when dew is formed on grass, it is because the ground is cooled during the night and the water vapor condenses on the grass, plants, and other objects.

Evaporation

Materials: 2 water tumblers with equal amount of water.

Directions: Place one glass where it is exposed to a breeze or in front of an electric fan. Place the other glass in a cupboard or away from any air movement. Observe the two tumblers from time to time. The water will evaporate faster from the tumbler exposed to the moving air.

Model of Foucault Pendulum

Materials: swivel chair, wastebasket, string, stick, and a metal weight.

Method: Place the wastebasket on the swivel chair and suspend the weight which has been attached to the string from the stick placed across the top of the wastebasket. Make sure the weight hangs freely. Start the weight swinging in a north-south direction and slowly rotate the chair. The pendulum will continue to swing in a north-south direction. The students can compare the rotating chair to the earth. This experiment helps children to understand how the earth rotates on its axis.

Cardboard Greenhouse

Materials: cardboard box, a polyethylene dry cleaning bag.

Method: Cut out the sides of the box and drape the dry cleaning bag over the top to control the humidity. Place small plants and seedlings in containers in the bottom of the box. One-third of one side of the box should not be draped to keep mold from forming. Let the box get as much indoor sunlight as possible. The plants will thrive and will not need to be watered frequently.

GAMES

Magnet Game

Materials: Coins, wire, pencils, eraser, rocks, string, etc., almost any type of articles, making sure that some of the articles are attracted to magnets. Have at least 40 to 50 small items.

Directions: Each child playing picks out one article from the table at a time. One child is chosen to be "it". This person has a magnet and approaches one of the other children and asks "Do I attract you". The child asked must then answer yes or no, depending on whether he thinks the magnet will attract the article he has chosen, and then the article is tested with the magnet. If he is right, then he gets the magnet and moves to another child, but if he is incorrect, the person who was "it" will continue. After a child has had a turn with the magnet, he then chooses another article from the table.

Picture Dominoes

Materials: 3" x 5" cards so that each player will have 10 cards (as many as six can play the game). Paste or draw pictures with scientific symbols on the end of the cards. Most of the cards should have different symbols on

the cards. Cards would look like this:

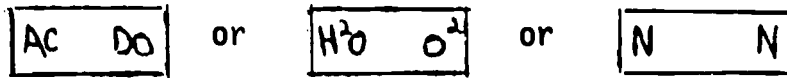

Directions: Each player receives an equal number of cards. One player should be designated as the dealer. After the cards have been dealt, the first person to the left of the dealer with a double card

starts by placing this one card on the table. Each player takes his turn of matching a symbol. If a player cannot match a symbol with one side of a card, then he must pass. When a double card is placed it must be placed vertically. The object is to see who can use up all their cards first. The cards could be made with many different things such as plants, animals, flowers, etc. Also the child should identify the symbol as he plays it.

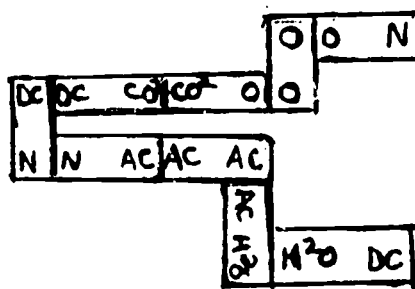

Identifying Sounds

Materials: Tape recorder - tapes - record everyday sounds. Children could help to record sounds, such as starting a car, bouncing a ball, clock alarm, etc.

Directions: Seat children in a circle with the tape recorder in the center. The first child to identify a sound gets to move next to the tutor and each child then moves up one chair and the one who is by the tutor moves to the end. This also can be done with teams, and giving points to the team as they correctly identify the sound. Set a time limit, and the team with the most points at the end of the time limit wins.

Adaptation: For older children this can be done with each person writing down what he thinks the sound is. The one with the most correct wins. This could be done in teams with each team preparing a tape for the other team to identify, making sure each team has an identical number of sounds. The older the children the more difficult the sounds should be.

Zoo Game

Materials: A 24" x 36" piece of oak tag. Draw a maze of 3" X 5" squares. In each of the squares place a picture of a flower, plant, element, etc. Before pasting the picture in the square, run a piece of yarn from start to finish so the child will know exactly the direction to go. Markers of construction paper (small), a pair of dice, or a spinner.

Directions: The child rolls the dice or spins the spinner. The one with the highest number goes first. The first child takes a turn moving the number of spaces indicated. He must then identify the picture. If he cannot, he moves back a square. The second player takes his turn, etc. The first child to reach the finish wins.

Shadow Fun

Materials: Paper and pencils for each child, filmstrip projector, large sheet, large pasteboard box, variety of two and three dimensional objects of various sizes and shapes (tin cans, pencils, dowels, blocks, cubes, etc.)

Directions: To make shadow box, cut a large circular hole in one end of a large pasteboard box. Stretch the sheet across the hole and fasten it down. Cut off the top and back end of the box. Focus the filmstrip projector light on the sheet screen. Place an object on the bottom of the box. The first player selects one of the objects and holds it in a position to cast a shadow on the screen. Holding objects in different ways will cast different shadows. Divide up in teams. One team holds the object as one of the members of the other teams attempts to identify the object. The team with the highest score wins. Besides identifying the shapes, objects should be identified as to whether they are flat or three dimensional.

Leaf Bingo

Materials: Several 3 X 3 cardboard squares with a leaf mounted on the card. Several larger cards 9 X 9 mounted with nine leaves (3 rows of 3). The leaves should be laminated to the cards to last longer.

Directions: Children take turns drawing the small cards and placing them on their larger card, if it matches. If it does not match any, they place the card face down in another pile. The object is to get three cards down, across, or diagonally, or if stated before the game starts, fill the complete card. The child who does this first wins. Other categories of science may be used.

Crossword Puzzle

Answer to puzzle on page

C
O T
M H
PULLEY
A R
S MAGNET
S O E
MICROSCOPE
E T
T BATTERY
SCALE U
R B
E

SPIRIT MASTERS

Spirit masters, for duplicate copies, may be made of materials on the following pages.

SENSE BINGO

SEE	SMELL	HEAR	FEEL	TASTE

Directions: As you hear the name of an object or subject, write it under the sense that defines it the closest. When a line is filled either up or down, across or horizontally, call out Bingo. Some subjects could fit into more than one place, so put it in the one that you believe is strongest.

*Des Moines Area Community College
2006 Ankeny Boulevard
Ankeny, Iowa 50021*

PLANTS FOR EATING

ROOT	STEM	LEAF	FRUIT	SEED

Directions: Classify the following foods under the proper description. The person who completes the list first with the most correct wins.

- | | | | |
|-------------|---------|-----------|-------|
| Spinach | Celery | Carrot | Lemon |
| Apple | Orange | Radish | Beet |
| Potato | Cherry | Asparagus | |
| Lettuce | Cabbage | Beans | |
| Grape | Corn | Banana | |
| Cauliflower | Peas | Peach | |

Des Moines Area Community College
 2006 Ankeny Boulevard
 Ankeny, Iowa 50021

SCIENCE CROSSWORD PUZZLE

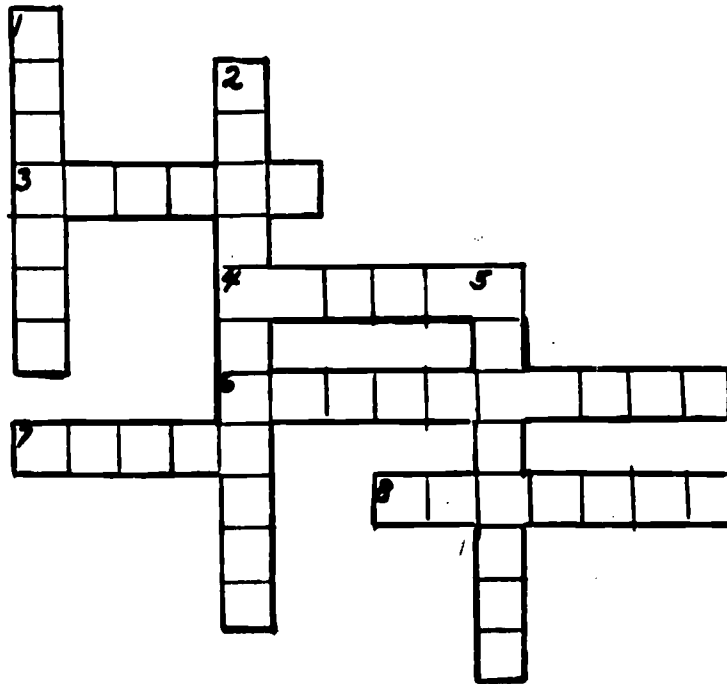

Down

1.

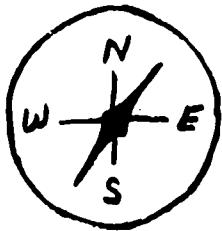

2.

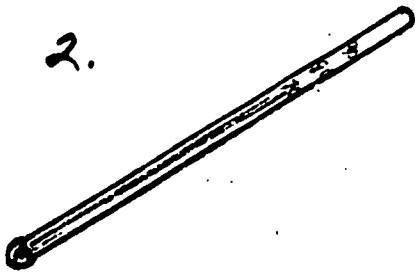

5.



Across

3.



2.

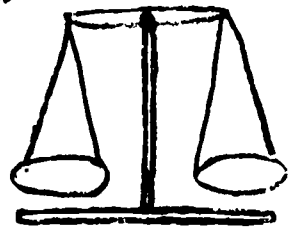

8.



4.



6.



INERTIA

- Marble
(that is larger
than hole in
bottle)

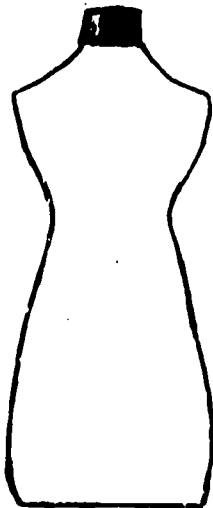

Plastic detergent
bottle filled with
water to make it
sturdier



1 1/2" X 1 1/2" square
of index card

Directions: Place card on top of bottle. Place marble on card. Using middle finger or ring finger, flick card from bottle. Marble will remain. It is sometimes easier to flick at "point" of card than at side.

When I shoot the card away the marble stays. This is because of a word called inertia. Because of inertia, objects want to stay where they are and if the action is speedy enough, there is not time to overcome inertia.

Did you ever see a man on TV pull the tablecloth off and have the dishes stay there? If he is fast enough there is not time to overcome the inertia of the dishes and they stay. I wouldn't suggest you trying that though, since it is rather difficult.

INERTIA II

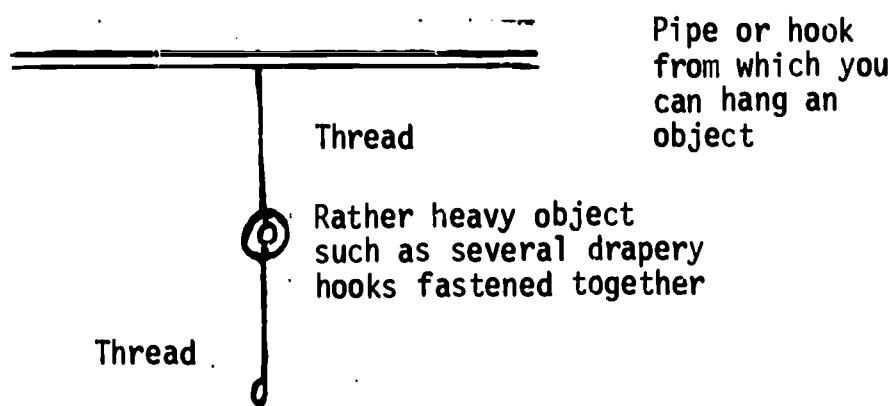

Directions: Suspend drapery hooks or other small, heavy object by thread with another thread hanging below. Ask students where thread will break, below or above weights when pulled at bottom. Pull slowly - thread will break above weight or pull quickly and thread will break below weight. Repeat with either fast or slow pull. It is interesting to do whichever the fewer students expect.

This is another experiment about inertia. We said objects want to stay as they are because of inertia. The weight would just as soon stay where it is so if you pull the thread quickly, there is not enough time to overcome inertia and the thread breaks below the weight. If you pull the thread slowly, there is time to overcome inertia so the weight is an added force pulling on the top thread, since the top thread has more force on it, it breaks.

Just as objects that are not moving want to stay motionless, objects that are moving want to keep moving in the same direction. Did you ever slide along the car seat when it went around a curve? This is because your body wants to keep going along in the same direction it was going when the auto turned.

SECOND LAW OF MOTION



Directions: Take a spool of thread and rewind several turns so end of thread is near center of spool and about 10 inches extending out. Place on table as shown so free end comes out from under spool. Ask students which way spool will move when thread is pulled in direction indicated. Then try it.

Spool will move in direction of pull. Newton's law states that the motion is in the same direction of the force. When you shove a box you expect it to go in the direction in which it was shoved. People often do not expect this to be true in the thread experiment.

The reason many people expect the spool to move the opposite way is that they have tried to pick up a spool of thread from under a table and it unwinds. This is because they are pulling up on it and the force of gravity is pulling down, causing the unwinding. In this case you have the force of gravity causing motion in another direction.

CONSERVATION OF MOMENTUM

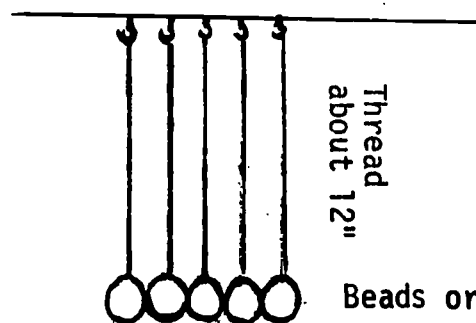

Board or dowel rod with 5 cup hooks spaced at distance equal to the diameter of balls

Directions: Attempt to have all balls hanging at same distance from support. Hold against wall or table edge so balls will not bounce around. Take one ball off to side and release, one ball will go off other side. Repeat for 2, 3, 4, 5 balls and same number will always go off other side.

The principle used here is called the conservation of momentum. This can be stated that you get as much momentum out of an action as you put into it. Momentum depends on how heavy something is and how fast it is moving. Since all the balls are the same size, the weight times the speed on the one side equals the weight times the speed on the other.

The amount of momentum an object has is important. For example, a slowly moving boat has a lot of momentum because it is so heavy. A little tiny bullet has so much momentum when it is fired because it goes so fast. You wouldn't want to be in front of either. If you dropped an apple on your hand it wouldn't hurt much but if someone dropped one from on top of the school and it hit you it would hurt. It would weigh the same but it would be moving faster so it would have a lot more momentum.

ACTION AND REACTION

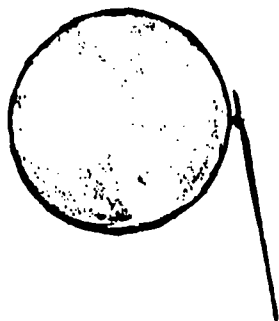

Balloon

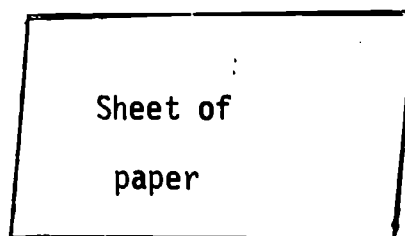

Sheet of
paper

Directions: Inflate balloon, holding closed. Let the air out. The air will go one direction, the balloon the other. Place the paper on a smooth floor. Step off. The paper goes backward as you step forward.

A law of motion says "for every action there is an equal and opposite reaction". The air going one way caused the balloon to go the other. The same is true of the paper.

Rockets go into space as gases go toward the ground. If you step off a boat or skate board it goes the opposite way. Lawn sprinklers turn because of this principle.

RESONANCE

Use conservation of momentum apparatus
removing ball 2, 4, 5.

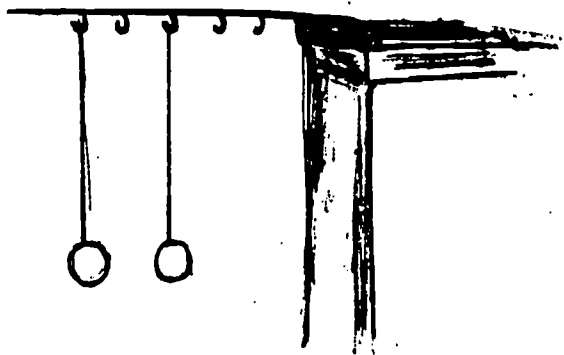

Hold over table edge

Directions: Begin one ball moving in and out like a pendulum. After a brief time the other ball will begin moving and will soon be moving as much as the first.

Because of resonance we can hear the vibration of a guitar string. When two things vibrate with the same frequency they reinforce the action. The two pendulums have the same frequency because the strings are the same length. When one begins vibrating the other picks it up because it has the same frequency. If they had different lengths this would not be true. You can hear the guitar string sound because the case and air in the large case begin vibrating and reinforce the sound.

Did you see the commercial on TV where the man sings a high note and breaks a glass? This happens because the vibration frequency of the glass is the same as the note the man hit. The glass begins vibrating and breaks.

REFRACTION

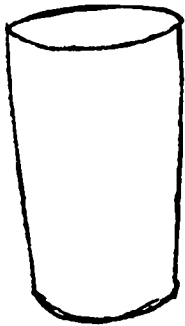

Empty
glass

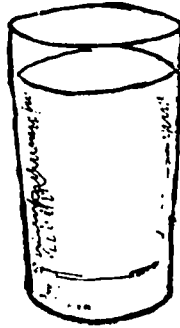

Glass
of
water

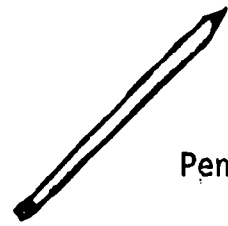

Pencil

Two pennies



Directions: Part I - Place penny at same position in both glasses. It will appear to be in a different position in the glass with water. Part II - Place the pencil in the glass of water at an angle. It appears to bend when viewed from the top.

The penny is at the same spot but appears to be higher and nearer the center in the glass with water. This is because our eyes are used to looking at things in air and we expect them to be where we see them in air. Light does not travel as fast in water as in air which causes this illusion. The pencil viewed from above appears to bend although it does not for the same reason.

If you ever go fishing and think you see a fish, it is not where you think it is. It is really deeper and closer to you than it appears.

STATIC ELECTRICITY

Small amount of
sawdust

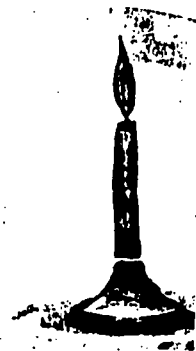

Old
candle

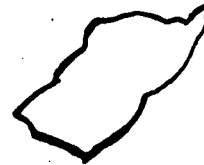

Piece of
wool or
fur
(not man-
made)

Directions: Rub bottom of candle vigorously with wool or fur. Stick into sawdust and remove. Sawdust will stick to candle but begin "shooting" off.

The sawdust at first stuck to the candle but then began shooting off. This is because rubbing the candle gave it an electrical charge - we could say it gave it some extra electrons. As the sawdust remained on the candle it also got some extra electrons. When a piece of sawdust got the same kind of charge as the candle it didn't want to be near the candle and "shot" off. There is a rule that says, "like charges repel and unlike charges attract".

There are many examples of electrical charges being built up. Did you ever walk across the room and touch a door knob and get "shocked"? This is because you became charged by walking across the wool rug and when you touched the knob the electrons left quickly and caused a little spark. Lightning will happen when a charged cloud near the earth suddenly loses its charge.

HOW TO MAKE A FIRE EXTINGUISHER

Equipment: A glass milk bottle and a one-hole cork or rubber stopper to fit, one eye dropper with the squeeze bulb removed, baking soda, vinegar, string, and a small bottle that will fit inside the milk bottle such as a pill bottle or a perfume bottle.

Procedure: Fill a milk bottle about half full of water and add 4 tablespoons of baking soda. Stir the mixture. Place the eye dropper through the one-hole cork with the tip pointing out (be careful not to cut yourself by trying to force the dropper through too small a hole in the cork). Fill the small bottle with vinegar, tie a string around it, and hang it above the water by placing the cork in position in the milk bottle.

To operate the extinguisher, turn the milk bottle over and keep it inverted until flames have been extinguished.
Note: This extinguisher will only be effective for very small fires.

Discussion: When the milk bottle is turned over the vinegar mixes with the baking soda and a chemical reaction occurs.
The reaction is:

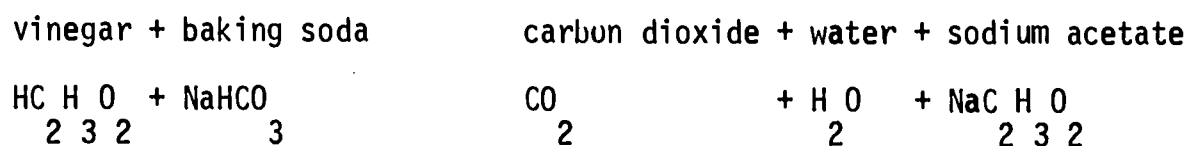

The carbon dioxide is a gas and it pushes the water in the bottle out the eye dropper.

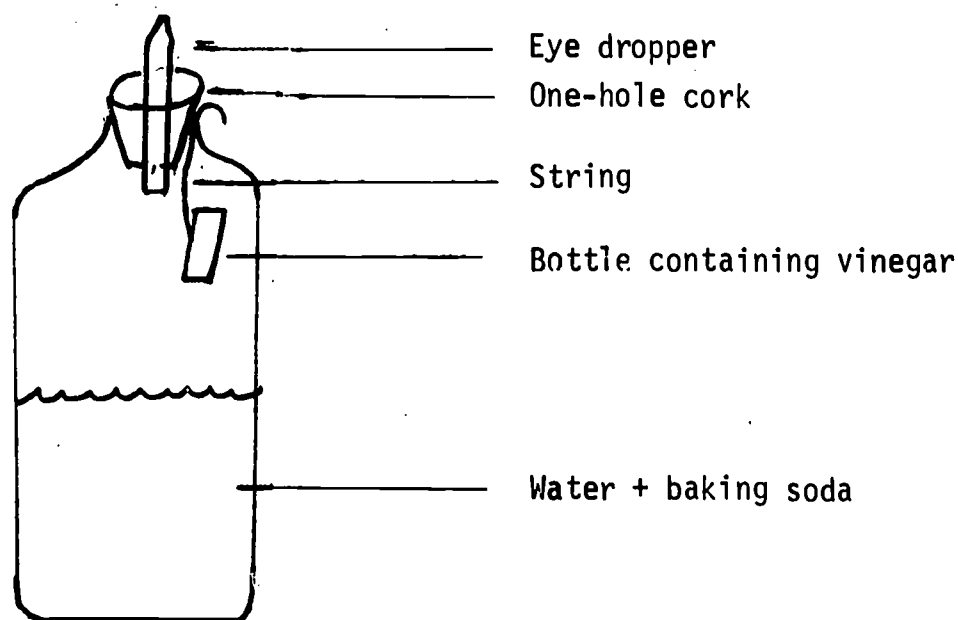

INTEREST INVENTORY

After school I like to _____

My favorite television programs are _____

My favorite game is _____

The subject I like best in school is _____

My favorite science is _____

My hobby is _____

How do you like the following science topics: Check in blanks how you feel about the activity or subject.

	DON'T LIKE	LIKE A LITTLE	LIKE A LOT
Animals	_____	_____	_____
Astronomy	_____	_____	_____
Weather	_____	_____	_____
Gardens	_____	_____	_____
Experiments	_____	_____	_____
Transportation	_____	_____	_____
Fish	_____	_____	_____
Insects	_____	_____	_____
Cooking	_____	_____	_____
Chemistry	_____	_____	_____
Photography	_____	_____	_____
Electricity	_____	_____	_____
Inventions	_____	_____	_____
Engines	_____	_____	_____
Rocks	_____	_____	_____
Pollution	_____	_____	_____
Sound	_____	_____	_____
Magnets	_____	_____	_____
Light	_____	_____	_____
Space	_____	_____	_____

SCIENCE GLOSSARY

acid - chemical compound which will dissolve in water, and has a sour taste. When it is dissolved in water it will separate into two or more electrically charged parts.

algae - single-celled plant containing chlorophyll.

alternating current - electrical current that flows back and forth.

amoeba - shapeless, one-celled protozoan.

amphibian - animal that develops lungs and lives on land as an adult, but will live and breathe underwater.

anemometer - instrument that is used to measure the speed of the movement of air.

aneroid barometer - instrument used to measure the pressure of air. The air pressure squeezes a metal box, which in turn moves the pointer.

annelid - invertebrate animal that has a body that appears to be divided by small rings. Example: earthworm.

arthropod - invertebrate animal with articulate, or outer skeleton, body and limbs. Example: crustaceans and insects.

asteroid - small heavenly body, much like a planet, that orbits the sun between Jupiter and Mars.

astronaut - traveler in space. The word means "star sailor".

astronomer - person who makes observations of the heavenly bodies.

astronomy - science of study of heavenly bodies.

atmosphere - gaseous mass, enveloping a heavenly body, such as a planet.

atom - bit of matter; the smallest amount of an element.

attract - to draw together.

axis - an imaginary line which a body rotates around. Imaginary line running through the earth from the North to the South Pole.

axle - shaft on which a wheel revolves.

bacteria - living one-celled things that do not contain chlorophyll. They grow on materials from which they derive their food.

barometer - instrument which measures air pressure.

battery - group of two or more cells connected together to create an electrical current.

boiling point - temperature when a liquid starts to boil.

botanist - person who studies plants.

carbohydrates - chemical compounds containing hydrogen, oxygen, and carbon, with twice as much hydrogen as oxygen; a main classification of food.

carbon - element of which coal is made. It is also found in graphite and diamonds. This is one of the most important elements in chemicals found in living things.

carbon dioxide - CO_2 - a compound made up of carbon and oxygen that forms a gas in the air.

carnivore - animal that eats other animals.

cell - small living part of a plant or animal. A basic unit of life.

chemical change - changes which happen when molecules are broken, or combined to form different molecules.

chemical equation - formulas and symbols placed together to show how atoms and molecules react to one another.

chemical formula - chemical symbols which are written together showing the atoms in a molecule.

chemist - person who studies the changes in matter, and works with chemicals and chemical changes.

chlorophyll - chemical compound which gives green color to plants.

chordate - animal with a spinal cord.

circuit - path an electric current travels.

classification - method of dividing things into groups under similar characteristics.

closed circuit - where no gaps or openings occur in an electric current.

coelenterate - invertebrate animal that is hollow inside and generally has tentacles or arms. Example: coral.

combustion - quick burning or oxidation.

comet - celestial body traveling through space composed of a cluster of gases, dust, rock and ice.

compass - device used to determine directions by means of a magnetic needle.

compound - a substance that is made up of more than one type of atom. The atoms are bonded together into molecules.

condense - to change a gas or vapor into liquid.

conduction - movement of heat from molecule to molecule through a substance; also the movement of electricity through a substance.

conductor - material that heat or electricity will easily travel along.

constellation - cluster of stars that appear to form a picture.

contract - to decrease in volume when molecules move close together. To use less space.

cylinder - metal tube containing an engine in a piston.

density - quantity of matter found in a certain volume of material.

dew - moisture condensed on objects when the air cools.

diameter - distance through a circle, from one side to the other.

direct current - when electric current flows only in one direction.

dissolve - to mix completely throughout a material, usually a liquid.

echinoderm - invertebrate animal with a spiny skin. Example: starfish.

echo - sound reflected off an object.

eclipse - passing of one body in space into the shadow of another body.

electric cell - structure used to produce electricity by the action of chemicals; contains electrodes and an electrolyte.

electric charge - basic unit of electricity; amount of electricity contained in an object.

electric current - flow of electrons.

electric resistance - force acting against the electricity flow.

electrolyte - material which conducts electricity when dissolved in water.

electromagnet - iron core found in a coil of wire which acts as a magnet while electricity is flowing along the wire.

electron - subatomic particle with a negative charge, usually found orbiting the nucleus of an atom.

element - material with only one kind of atom.

energy - anything other than substance, necessary for something to move or change.

environment - everything affecting living plants and animals; the total surrounding.

equator - imaginary circle which surrounds the earth at a half way point, between the north and south pole.

erosion - process of wearing away the materials of the earth's surface.

estivation - hibernation during the summer months.

evaporate - changing of a liquid into a gas or vapor.

expand - to increase in volume as matter moves farther apart; to use more space.

extinct - something with no descendants, and itself is no longer living.

Fahrenheit scale - thermometer with freezing at 32° and boiling at 212° .

fertilizer - material that contains minerals needed by plants for continued growth.

fluorescent mineral - mineral which will glow under ultraviolet light, but not under ordinary light.

focus - point where light comes together when reflected from a curved mirror.

fog - condensed water vapor found near the ground that forms a cloud.

footcandle - measurement for the brightness of light which is based on the amount of light given by a candle from a one foot distance.

force - to pull or push.

fossil - any type of preservation of a plant or animal that lived in the past.

friction - force found when two objects are rubbed together; resistance to rubbing.

fulcrum - point on which the arm of a lever rests.

galaxy - large star cluster like the Milky Way, that contains billions of stars

gas - state of matter with no shape or volume, either liquid or solid, that takes the shape of its container.

gear - wheel with teeth in it.

Geiger counter - instrument used to detect radioactive materials.

generator - machine that changes mechanical energy, or water or steam power into electricity.

geology - study of the earth and rocks from which the earth is made.

glacier - huge mass of ice moving on land.

globe - model of the earth or any other body.

gravimeter - instrument for measuring the differences in the effect of gravity.

gravity - force pulling things to the center of the earth.

heat - energy relating to the movement of molecules.

herbivore - animal that will eat only plants.

hibernate - to spend an expanded period of time in a state resembling sleep.

humidity - amount of water vapor found in air.

humus - decaying plant and animal materials found in soil.

hurricane - huge storm made up of circular winds of great speed and rain.

hybrid - plant that is produced by flowers that have been pollinated by a different kind of flower.

hydrometer - instrument used in measuring the density of liquid.

hygrometer - instrument used in measuring humidity.

incandescent - giving light when heated.

insulator - material that does not conduct heat or electricity well.

invertebrate - animal with no backbone.

irrigation - process of bringing water into dry places.

kinetic energy - energy of motion.

laser - instrument that is used to produce concentrated and almost perfectly parallel rays of light.

latitude lines - lines counted in degrees, that are drawn parallel to the equator on a globe.

lens - piece of transparent material that will refract light, and changes the direction of light when it travels through it.

lever - simple machine that is made up of an arm and a fulcrum.

lichens - small greenish-gray plant that grows on rocks and gives off acids that soften the rock minerals.

lightning - electrons moving between two differently charged objects, giving off a flash of light.

light-year - unit used in measuring great distances; distance that light travels in one year at 186,000 miles per second, approximately 6 trillion miles.

lines of force - lines around a magnet that show the magnetic field.

lipids - main class of food containing fats and oils. Also, chemical compounds that contain carbon, hydrogen, and oxygen.

liquid - matter that is neither gas nor solid, which flows and will take on the shape of its container.

longitude lines - lines that are counted in degrees, and are drawn on a globe from the north pole to the south pole.

lunar eclipse - when the earth passes between the sun and the moon and either part or all of the moon is left in the earth's shadow.

magnetometer - instrument used in studying magnetism.

mammal - animal with a constant body temperature, covered with hair, and its female produces milk for its young.

mantle - middle layer of earth underneath the crust.

mass - total amount of matter in an object.

mercury - element which at room temperature is a very heavy liquid.

metamorphic rock - rock that is changed by heat and pressure.

metamorphosis - changing in form.

meteor - piece of matter that moves into the earth's air from space.

microscope - high powered instrument that makes very small objects appear larger.

mildew - fungus that grows on plants and other materials that are damp.

mineral - natural substance, element or compound in the earth.

mixture - when one or more things are added together.

molecule - minute bit of matter; the smallest amount of a compound that contains all the properties of that compound.

mollusk - invertebrate animal with a hard shell and a soft body. Example: clam.

molting - shedding of an outer skeleton or skin.

negative charge - charge of an electron; a minus charge.

neutral - no electric charge given off.

neutron - subatomic particle that has no charge.

nuclear energy - energy created from nuclear reactions.

nuclear fission - reaction in which an atom is split and releases a great amount of energy.

nuclear fusion - reaction in which two or more atoms join and produce a different atom that releases much energy.

nuclear reaction - changing one kind of atom to another kind of atom.

nucleus - center of an atom made up of protons and neutrons tightly packed together; central part in the cytoplasm of a cell.

omnivore - animal that will eat both plants and animals.

opaque - when no light is allowed to pass through.

orbit - when one object moves around a larger object.

organ - tissues working together.

oxygen - gas found in the air which is necessary for life; most abundant element found on earth.

periscope - instrument used to see around and over objects, that is made of prisms or mirrors.

photosynthesis - process in plants where water, carbon dioxide and sunlight combine, forming sugar and oxygen.

pitch - highness or lowness of sound. The up and down motion of a spacecraft or rocket.

planet - large body in space moving around the sun.

planetarium - building with a dome-shaped ceiling on which images of the stars are projected.

pole - ends of the earth's axis, also the ends of a magnet.

pollen - grains of powder-like cells needed in fertilization that are produced by the stamens of a flower.

polluted - something containing harmful wastes.

poriferan - invertebrate animal whose body is full of holes. Example: a sponge.

porous - to allow liquids to pass through.

positive charge - charge of a proton; a plus charge.

prism - type of glass that will separate white light into its colors.

protein - main classification of food. Chemical compounds containing hydrogen, oxygen and nitrogen.

proton - subatomic particle with a positive charge.

protozoan - one-celled animal-like living thing.

pulley - lifting tool devised from a grooved wheel and an axle machine.

radiation - movement of heat rays away from a warm object; atom giving off protons, neutrons, electrons or energy.

rain - drops of water that fall, that have been condensed from water vapor in the air.

rain gauge - instrument used in measuring the amount of rainfall.

reflect - something bouncing off a surface.

refraction - changing the direction of light by passing it from one material to another.

relative humidity - amount of water vapor in the air in comparison to amount of water vapor the air can hold.

reptile - animal with scales that breathes through lungs and has a changeable body temperature.

resistance - force withholding something as it passes over or through material.

revolve - to move around another body.

rotate - to turn around about an axis.

sap - in a plant, the food dissolved in water.

satellite - an object in space traveling around a larger object.

satellite tracking - use of instruments to follow a satellite in orbit.

scale - instrument used in measuring weight.

scales - flat, thin plates that cover a plant part or on the skin of an animal.

sediment - material settling out of water.

seismograph - instrument used in recording vibrations within and on the earth.

smog - air that contains harmful wastes trapped by moisture.

solar cell - object containing materials which will produce electricity by receiving light.

solar eclipse - when the moon passes between the sun and the earth so that part or all of the earth is in the shadow of the moon.

solar system - sun and all other heavenly bodies, such as planets and meteors, that move around the sun.

solid - matter that has its own shape, that is neither gas nor liquid.

spectrum - band of colors that is produced when white light is separated.

sperm - cell from a living thing, that can join an egg from another living thing; when joined they will produce a new living thing.

sphere - ball shaped object.

stamens - part of the flower that produces pollen.

star - object found in space that makes its own light; ball of incandescent gas that glows by nuclear reactions.

static electricity - electric charges that are non-moving.

subsonic - when vibrations are too slow to hear.

supersonic - speed traveling faster than the speed of sound.

system - group of parts working together as a unit.

telescope - instrument that makes distant objects appear closer.

temperature - measurement of the warmth and coldness of an object.

theory - best information given with the information available.

thrust - to push against the force of gravity. This term usually is used in relationship to the push of rocket motors.

tissue - similar cells grouped together.

tornado - large storm with whirling winds and funnel shaped clouds.

translucent - article allowing some but not all light to pass through.

transparent - article which allows most of the light to pass through.

troposphere - layer of the atmosphere found closest to the earth.

ultrasonic - vibrations moving so fast they cannot be heard.

variable star - star changing in brightness and size from time to time.

vertebrate - animal with a backbone.

vibrate - moving back and forth several times.

volcano - mountain formed from lava.

volume - measurement of the amount of space.

watt - measurement of the amount of work done per second by flowing electricity; this unit measures the brightness of a light.

weather satellite - satellite with instruments aboard sending weather information back to earth.

weight - heaviness of matter, measured on a scale and caused by gravity.

wheel - round object that revolves on an axle.

windlass - wheel and axle machine that is used as a lifting tool.

yaw - measurement of a rocket as it moves from right to left.

yeast - fungus used in making most types of bread.

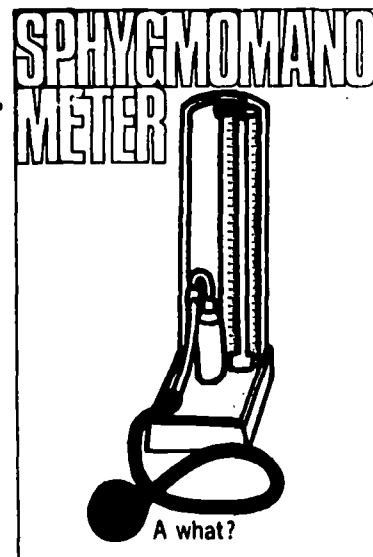



CHAPTER SIX

VISUAL, AUDIO AND TACTILE MATERIALS FOR HANDICAPPED CHILDREN

TIPS ON WORKING WITH HANDICAPPED

Handicapped is a term that designates many different disabilities. It is difficult to completely report all phases; we have chosen to describe techniques and ideas for working with the -

1. Physically Handicapped
 - A. Orthopedically Handicapped
 - B. Aurally Handicapped
 - C. Visually Handicapped
2. Learning Disabilities or Perceptually Handicapped
3. Educable Retarded
4. Bi-Lingual Student
5. Emotionally and Socially Handicapped
6. Gifted and Creative

The handicaps discussed in this chapter are ones that could be found in the regular classroom. Children with extreme difficulties undoubtedly would be placed in special schools, and therefore material covering these particular cases have not been included.

Many games and activities mentioned in the Science and Math chapters are applicable or adaptable for handicapped children. A glossary of terms is included and games and activities with emphasis on use of visual, audio and tactile materials.

PHYSICALLY HANDICAPPED

ORTHEPEDICALLY HANDICAPPED¹

It is said, "Not as a rule, but very often we find that the patients most severely involved physically are often the least seriously involved mentally." Severe physical handicaps make a person's true mental capacity extremely difficult to evaluate.

"The orthopedically handicapped child is a very precious individual, and potentially can make a valuable contribution to their community. They are special because they have physical handicaps to which they must adjust their lives; special because they have experienced unusual problems resulting from their physical handicaps, and special because they need and deserve extra aid in learning to be useful, happy citizens of our world. They are worthy of our best efforts to motivate them to their best potentialities." ²

Some crippled children show evidence of being rejected by their parents. Often evidences of emotional insecurity, such as thumb sucking, will be noticeable. These children can be over dependent and fail to help themselves as much as they actually are capable of doing. Because children probably have

¹ and ² Handbook for Counselors, Camp Sunnyside, Des Moines, Iowa

been restricted at home, they could become boisterous at school. A few children go through periods of mental depression; this is especially true of adolescents. However, in the case of adolescents, this should be weighed in relation to similar situations with normal adolescents. Those children in whom the handicap is of recent origin seem to be more prone to depression than those with physical defects over a longer period of time. It is not unusual if a feeling of inferiority has been built up over a period of years. Keeping this in mind, it will be easier to understand why some children might refuse to enter into some activities.

The volunteer will need to meet conflicts as they arise. You, along with every other person the child contacts, will add to his growth. Hopefully you will be in a position to contribute much to the youngster's success in living.

Anyone desirous of becoming a tutor of the orthopedically handicapped child is offered a real challenge. It is important for the volunteer to remember that although the child is physically crippled, his mind can be strong and alert. Always keep in mind that they are children first; and crippled children second. The following commandments should be remembered as tutoring is done. These can apply not only for the handicapped but for all children.

- Be tolerant - try to place yourself in the child's situation, and think back to when you were a child. Cultivate a child's point of view.
- Be unselfish - place the child's interests before your own. Do all in your power to make the time spent with you rewarding to the child.
- Be cheerful! Cheerfulness is contagious. If you are cheerful, undoubtedly the child also will be happy.
- Be sympathetic with the child's enthusiasm.
- Set a good example for the child at all times.
- Be punctual and thorough in every detail.
- Do not threaten or promise anything which you cannot reasonably and fairly bring to a conclusion.
- Be loyal to your program; avoid gossip.
- Be a model of good moral standards, ideals and character.

It is important that you assure the child with whom you are working that you are interested in him. Be casual and informal, and above all don't ask embarrassing questions. Develop a trust with your tutee.

Show interest, sympathy, and understanding toward the child. However, if there is more than one child involved, be careful to show no favoritism. Manifest your sense of humor, and above all have faith in what the child can accomplish.

If behavioral problems arise, first consult with the teacher, as it is the teacher's responsibility to discipline. Try to understand why the situation arose, rather than what transpired. Attempt to create a sense of responsibility

in the child. Never hit the child even in play; the meaning of this could be misconstrued. If this were observed by other children they may not realize that it had been done in fun.

Employ a positive approach when working with your tutee. Use the word do rather than don't. Prohibiting something attempts to repress, rather than encourage activities. A direct command is likely to arouse antagonism, whereas a tactful hint for something you want done quite possibly could arouse enthusiastic participation. Always try to convey the impression you believe the child is doing the right thing. If the child does fail, you might feel disappointed, but do not become discouraged.

Express pleasure and approval with the child. This will show how highly you regard his efforts. This could further draw out positive and constructive responses. Rapport is developed by wise use of commendation. Help the child to develop a sense of self-appreciation. Self-estimates are largely based on what you think others are thinking of you. Commendation must be characterized by genuineness and sincerity.

The following Tips on Dealing with the Orthopedically Handicapped were adapted from "Progress", December-January 1956. These were written by A. H. Carlson, Ph.D., Superintendent, Crippled Childrens School, Jamestown, North Dakota, and is valuable information for the volunteer tutor to know to be able to adjust to any situation that may arise.

1. Offer help when it looks as though it might be needed but do not insist on it if the individual refuses aid.
2. Don't "hover". Handicapped individuals do not wish to be treated as babies; they want to be like you and me.
3. When a handicapped person falls, take it easy. Wait for him to give you a cue. If he can get up by himself, he may prefer doing that. If he needs a lift, he will tell you which is the best and easiest way to get him back on his feet.
4. Crutches and wheel chairs are necessary accessories. Don't take them away from the handicapped person unless he indicates he would like to have them out of the way. Nothing is more irritating than to have your crutches grabbed quickly as soon as you hit the chair, leaving you stranded. Pushing wheel chairs is a necessary skill to be learned. If you are working with a student who is confined to a wheel chair, it probably will be necessary for you to learn this skill.
5. Vehicles are difficult even for the young and agile. The handicapped often need help here. Again let them tell you how to help. Those who do not need to be carried up the steps usually have methods of their own for making them. Do not pull an arm or push from behind unless such assistance has been asked for. Precarious balance can be lost entirely with such tactics. Lifting of the handicapped child requires certain skill as well as strength. Women should consider each lifting act carefully, and get help from one another whenever possible.
6. Keep your perspective. Remember an arm is an arm and a leg is a leg, and one handicapped limb is not the whole person.

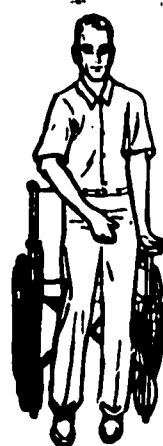

7. Relax. No matter what you do, if you are friendly and kind, the handicapped person is going to like you.
8. Have fun. Talk about the same things you would with any other person. A physical handicap does not necessarily limit your interests or dampen your sense of humor.
9. Let common sense and consideration be your guide, and you will never err seriously. The disabled are just like you, only with a physical difference, that does not have to make them feel or think differently.
10. Be yourself. Don't be sticky sweet. Omit the pious note.
11. When in doubt ask: "May I help you?" "How can I help?"

Because the orthopedically handicapped child has senses of sight and hearing, media devices can be particularly helpful and effective, in both visual and audio presentations. These children also enjoy games and activities as much as the normal child.

AURALLY HANDICAPPED¹

"Most of us take hearing for granted. We can't imagine not being able to hear. Think of the first few minutes of a day. The alarm clock wakes us up. Rain is falling on the roof. Down the hallway somebody is taking a shower. From the kitchen comes the clatter of dishes.

"We seldom think about these sounds. But they tell us a great deal. They keep us in touch with what's going on. When we don't hear, it's like being in another world".²

We who have normal hearing take these sounds for granted and do not stop to realize what our world would be like without them. If these sounds were shut out, then perhaps we could better understand the feelings of children with hearing handicaps.

Hearing problems can be caused by many factors. It could be as simple as having wax in the outer ear, or as serious as a birth deformity. You, as a tutor, do not necessarily need this information, however, it is helpful for you to know if it is a temporary or a permanent loss. The more you can understand about the child with whom you are working, the more successful you might be.

If a child is having problems with a hearing aid, the best procedure would be to have the child check with the classroom teacher, or with his parents.

The two classifications for the aurally handicapped child are hard of hearing and deaf. The hard of hearing child has a hearing loss ranging from 20 to 60 decibels. The deaf child has a hearing loss anywhere from 60 to 100 decibels.

¹ Resource materials, Hearing Consultation Services, Polk County Board of Education, Des Moines, Iowa

² The Child is Hard of Hearing - pamphlet, U.S. Department of HEW, Office of Child Development - Childrens Bureau

The incidence of the hard of hearing child is much greater than that of the deaf child. A child can participate in the regular classroom if the loss is no greater than 40 decibels, but he will need to be seated where he can hear effectively. With a loss of 40-60 decibels a child can still participate effectively in the regular classroom as long as he uses a hearing aid.

The volunteer will most likely encounter the hard of hearing child rather than the deaf child, as the deaf child is generally educated in special classes, in which lip reading and sign language, or both, will be used.

The speech handicapped child is often found in conjunction with the aurally handicapped. Since the child is not able to hear, he does not realize that he is speaking improperly.

The young, hard of hearing child is interested in learning facts. They have a love of animals, flowers, birds and anything in the world of nature. Primary science becomes an important study because of the natural curiosity of the child. Inadvertently this helps the deaf child, because in the science study units, you also will be building the student's language comprehension and language skills.

The following general considerations have been adapted to assist the volunteer tutor.

Attempt to accept the hard of hearing child positively - no matter how inadequate his speech, his comprehension, or his vocabulary.

Don't overprotect the hard of hearing child. He should not be treated any differently from any other child of his age or intelligence. This helps him to feel more comfortable and that he belongs.

Remember that two children with almost identical hearing losses may function very differently and hence cannot be lumped into one general category. They should be motivated, taught, and challenged according to their own ability as individuals. Intelligence, social maturity and family background of hard of hearing children vary considerably. Any one or a combination of the above reasons could be even more significant than the child's hearing loss in determining his ability to function and learn.

Discover and encourage the hard of hearing child's special capabilities and interests just as you would a normal child. Don't assume, because he is hard of hearing, that he can't be gifted in science or art or poetry. It is of great psychological benefit to these youngsters to know that they can excel in something.

Help the children around the child to understand his handicap. Other children can be much less cruel when they understand another's problem.

¹ Adapted from article, A Guide for the Classroom Teacher, Phyllis Gildston, Ph.D. - Volta Bureau, Headquarters, Alexander Graham Bell Association for the Deaf, 1537 35th Street N.W., Washington, D.C.

Don't expect the hard of hearing child to understand all of the time, no matter how bright he may be or how hard he tries. You can be a buddy to him in the classroom, by furnishing directions that he was unable to catch from the teacher. You can also cue him in should he miss out on some of the class discussions or need notes to copy over at home. Since you will not be with the child every day, encourage him also to have a buddy from his classmates.

Try to use as many visual aids as possible to increase the number of sensory associations he can store, in order to facilitate his learning. Never rely solely on auditory cues.

The hard of hearing child has special vocabulary limits. Many words that the normal hearing child uses in the course of everyday conversation may be new words to the hard of hearing child. The normal hearing child has heard multiple repetitions of many, many words without attending particularly to their meaning or to the speaker who uses them. The hard of hearing child must learn by attending directly to the speaker and concentrating on the communication with all his resources.

Use some of the slang that is popular with the hard of hearing child's peers. This could be the link that connects him to the group. Don't be a fuddy duddy in your speech.

Don't speak with your back to the child at any time.

Don't mumble and gallop in speaking. However, don't overexaggerate your speech patterns. Articulate clearly and with moderate speed. If he reads lips, he has been taught to lip read normally articulated words.

Don't stand, in talking with a hard of hearing child, so that your face is in a shadow. Similarly, don't force a hard of hearing child to assume a position which forces him to try to lip read in an intense glare.

The hard of hearing child will undoubtedly take poor notes. It is extremely difficult for him to write and listen, as most of us can, while has to keep his eyes peeled to the speaker's lips in order to get the gist of what is being said. As a volunteer you can assist him in taking notes during lectures.

Stand fairly still when talking with the child. It is much easier for him to lip read, than if he also has to follow your other movements.

When reading orally to the child, keep your book down so that he may see your lips. Good eye contact is important.

Don't repeat the same question over and over again in its original form, when the child seems not to understand. Rephrase the question. You may be using words that look and sound alike to him but in reality are quite different.

Whenever new vocabulary words are used, write them on the board or a piece of paper. Don't expect him to understand new words with only aural clues and explanations.

Don't spring a topic "cold" on the child. Give him some advance notice as to what you will be doing the next time that you see him.

Don't hesitate to repeat for the hard of hearing child what another child has said. Not all children speak clearly, and sometimes they are hard to lip read.

Don't expect the child to lip read as well from a distance. Try to keep him in good visual range.

Try to learn something about the extent and nature of the child's hearing loss in order to understand his communication handicap. Many children face similar problems; however, each hard of hearing child's particular hearing disability makes his comprehension problem different.

If a child is wearing a hearing aid in only one ear, seat yourself so that he may have the best reception; the further he is from the source, the more difficult it is for him to understand.

Speak in a natural tone of voice. Only with certain types of losses does raising the voice help.

Encourage the child to be unashamed if he does not understand and to state his confusion or apprehension immediately.

The hard of hearing child does not always hear the sounds we hear (particularly sounds like s, f, th). Many sounds they do hear come through in a distorted manner. Because of this many children have a speech impediment. Compliment the child when he manages to use correctly the sounds that he has trouble with. Often he cannot hear himself so is dependent upon you to let him know when he does do it correctly.

Give the child as much opportunity to speak as possible. However, don't allow him to either shout or mumble. With your help he can be taught to modulate his voice.

Sources where additional material for the Aurally Handicapped may be obtained are:

The Speech and Hearing Service in your State Department of Health, or in your State Crippled Childrens' Agency

The State Vocational Rehabilitation Service

Hearing and Speech Centers (consult your State Agencies for the location nearest you)

The Veterans Administration, Washington, D.C.

American Academy of Ophthalmology and Otolaryngology
15 Second Street, S.W.
Rochester, Minnesota 55901

American Hearing Society
919 18th Street, N.W.
Washington, D.C. 20006

American Speech and Hearing Association
1001 Connecticut Avenue, N.W.
Washington, D.C. 20006

Alexander Graham Bell Association for the Deaf
1537 35th Street, N.W.
Washington, D.C. 20007

Hearing Aid Industry Conference
437 Merchandise Mart
Chicago, Illinois 60654

National Association of the Deaf
2025 I Street, N.W. Suite 311
Washington, D.C. 20006

Office of Education
U.S. Department of Health, Education, and Welfare
Washington, D.C. 20202

VISUALLY HANDICAPPED¹

"The definition of blindness is a complicated matter. Educationally, it usually means someone who uses braille and/or cane travel. Most blind persons do have some sight, which may or may not be useful in a given situation. For example, the child might be able to perceive most objects and read 3" letters, but not be able to read any regular print. One of the most difficult problems facing an individual with partial sight is determining when this sight is reliable, and when alternative techniques (usable by the totally blind) would be more efficient." This quotation taken from material prepared by Mrs. Winifred Beardsley, a consultant to the Des Moines Public Schools, can give some insight to the tutor in the work that is being undertaken.

Many blind children today are being placed in the regular classroom, once they have learned the use of braille. The role of the tutor with the blind child can be extremely helpful, as there will be times when the child will need assistance to keep up with the class.

It is the responsibility of the classroom teacher to make the child feel comfortable in the classroom. The teacher undoubtedly has explained to the other members of the class the child's disability in simple terms, and hopefully the blind child has been taught to do the same. If the subject is spoken about openly and truthfully, with the blind child present, it will help the rest of the class to understand and accept the disability, without feeling that this is something fearful and shameful that is not discussed. Although you are working primarily with the blind child, there will be times and circumstances when you will have contact with the classroom children. Once the children in the classroom have satisfied their natural curiosity, they will accept the blind child as a matter of course. Children generally tend to accept a disability more easily than adults.

The volunteer tutor can play an important role in working with the blind. Do not be alarmed if at first you feel awkward with the child, because as you work with the child your feelings will become more natural and relaxed.

¹ Information in this section furnished by the Des Moines Public Schools

The following suggestions can be helpful to the tutor. These are not rigid or all-inclusive, but can be adaptable for individual situations.

Attitudes

Help the child improve his general self-confidence. In doing this he will more readily enter into class discussion and participation. With your guidance, he can learn to contribute to the group in worthwhile ways. Also you can assist the child in learning to determine if he does or does not need help. He should learn to accept or refuse help pleasantly. Insist that the child never "use" his disability to escape work or responsibility.

It is important that you remember that blindness is merely a physical problem rather than a tragedy. A blind person sometimes does things differently, but then, no two people are alike. With proper training the blind person can lead a normal life. One of your responsibilities is to convey this to others with whom you associate.

Bulletin Boards

The tutor can assist the classroom teacher by seeing that braille labels are used in a display. As the child examines this, through touch, the display is adequately described to him. If it is a display on an extra curricular subject, you might prefer to encourage him to ask a friend about it, or if he wishes, to ignore it.

Conversation

1. Use the word "blind" naturally as you would any other characteristic. Do not dwell on it unduly. Use the words "look" and "see" in the usual way, although the blind person may examine the item tactually rather than visually.

2. Avoid the use of expressions such as "he did it blindly", which encourages the stereotype that blind people are helpless or ignorant. Criticize or commend the blind child as you would any other child. Avoid statements like the following: "We really forget that you are blind, since you are getting along so well". Although you mean well by such a statement, and is usually accepted as the way you intended, this is really a veiled barb. Its implication is that blind people usually do not get along well. The child knows that he is blind, and if he should develop a great desire to have everyone forget that he is blind, he is likely to reject such necessary aids as braille and cane travel.

3. Continue to use gestures and facial expressions as you normally do, but try to supplement them verbally so that the blind person is not excluded. Encourage the child in the use of his own facial expressions by using statements like the following, "My, you look scared John! I see you're really in the spirit of this ghost story".

Field Trips

The tutor can accompany the child on the field trip. Try to encourage other adults who are in attendance, such as mothers, tour guides, etc., not to be over solicitous. See that the blind student, if possible, gets to examine things by touch.

Orientation to Environment

It is desirable to show a new student around the room, preferably before the rest of the class arrives.

Keep the blind child informed when the location of familiar objects have been changed.

In pointing out objects, tap it as you indicate it, especially if the child is quite close to it. Also, give a verbal description. If the child is very slow in finding something, you may need to take his hand and show him, but he should become more and more able to find things with very little direction and help.

Address the blind child by name so that he is sure when he is being addressed.

Encourage classmates to mention their own names in speaking to him. If a visitor enters the room, see that the child at least is informed who it is, so that he will have the basic information that the others have gained by looking at the visitor.

Movies, plays, assemblies, etc.

Narrate quietly to the child as needed, so that he is aware of what is happening.

Arithmetic

The following suggestions will be helpful in working with the child in arithmetic -

Concrete objects or raised pictures

Lessons and books transcribed in braille

For clock study, the blind student will have a clock with raised markings.

If a clock is shown to the class, someone might state the locations of each hand before a student is asked to give the time shown.

When the blackboard is used, give the information to the child or supply the same material to him in braille.

If a multiple-choice type exercise is presented on the board, the item should be read aloud before children are asked to choose the answer.

Science Experiments

Have the blind child examine things tactually. Usually he can do all or most of the activities.

When a certain part of an activity is impossible for the child, such as reading a print dial, then make sure that he gets to take care of another facet of the work, such as making the computations needed in the reading of the dial.

When a demonstration is given before the class, the tutor can give a running description of what is happening to the child.

Tactile techniques, such as topographical maps, are useful methods. This can give the child the proportionate perspective of mountains, valleys, rivers, oceans, etc.

Research and Reference Work

Books in braille should be used when possible. When this is impossible, the volunteer then can become a reader to the child, or read the material into a tape so that the student can use it later either at school or in his home.

Younger children usually have not learned cane travel, and the volunteer can give assistance outside of familiar areas. It is most helpful if the blind person takes the arm of the sighted person. If possible this should be a gentle grip just above the elbow; however, a very small child may take the wrist of a tall adult.

If an individual is wondering about the blind child, you might make some casual comment in reference to blindness in the regular flow of conversation. You will be doing a grave disservice to the blind child, however, if you exploit him by showing him off. Attempt to promote natural attitudes, and help others to avoid such comments as, "How sad!" or, "How marvelous!"

Promote safety measures for the blind child. Be particularly cognizant of sharp or dangerous objects. Be sure that the child you are tutoring is aware of these objects, and that he knows the nature and location of them. Once he is aware of the safety hazard, then apply the same safety rules that are for the others, keeping in mind the child's age, skill and dependability. The volunteer could be helpful in teaching such a skill, such as the use of the pocket knife.

Finally, it is important to emphasize that the volunteer's role is not one of teaching. This is the responsibility of the classroom teacher, and the tutor is there to supplement the instruction given, and to reinforce and assist the child in the most practical way, whether in or out of the classroom.

LEARNING DISABILITIES

The perceptually handicapped child may function on different levels because his memory span can show great variability. Because of this, it is very difficult to test this type of child accurately and thus know what his true capabilities are. The teacher should know the specific characteristics of the child's learning patterns and thus be able to diagnose to the volunteer tutor the best ways that he can assist. The child with learning disabilities will have a variable memory span, so it is important to constantly review previously taught material before introducing further new material. The role the volunteer can assume is in redrilling of the previously taught material.

Conservation and science are natural curriculum tie-ins. Children love animals and by using one animal at a time, you will be able to hold the child's attention. With imagination the animal can not only be used for science but also for reading, spelling, and math. A subject becomes fascinating with a live image rather than a flat printed page.

The manuscript (printing) method of writing, where two or three lines are put together, should not be used with the perceptually handicapped as he will only experience failure in understanding. The cursive (written) method only requires the changing of the direction of a straight line and the pencil does

not need to be raised from the paper. If a tutor has worked previously with young children and is accustomed to using manuscript writing, it is important that he remembers and changes his methods of writing to cursive.

Because a child with learning disabilities is unable to refrain from reacting to any type stimuli, it is important to select carefully the tutorial setting. You should take the child to the quietest place available. It could be a very quiet, small room with nothing to distract the child's attention, such as pictures on the wall. Once a quiet non-stimulating spot has been selected the following steps should then be followed.

Talk with both the child's mother and teacher to find out what the child habitually can do well. From this point you start reinforcing. The teacher should keep you advised of current classroom failure. Starting at this point, it will be necessary to work backward to find where the child knows the material, and will give him a genuine positive experience. At this point then you start with positive reinforcement.

Carefully observe in several different situations the approximate extent of the child's attention span, and then plan your sessions accordingly. If his attention span seems to be only three minutes long, it is better to plan five three-minute activities than one fifteen-minute activity.

If necessary, use only one word or problem on a piece of paper so that visually hyperactive child will not be distracted. Sometimes these children are unable to distinguish figures from a background.

Assess how secure the child is by watching his responses in a given situation. If he displays any outward signs of tension, then there is something about the situation that is too disturbing for him to handle. As each new situation is presented, you will need to evaluate the result.

In working in mathematics, the following ideas and suggestions can be helpful.

Color cuing is very appropriate. Using the same color repeatedly to indicate the same concept, can be extremely helpful.

In using counters, sticks, or beads on a string, use the same color until the child repeatedly has a successful experience. Once this happens change one, and then another, until the child can handle them randomly. With a visually hyperactive child, give him only one stick or bead at a time. Do not give the child a choice until you are sure he can make that choice. It is better to underestimate the child than to expose him to another failure situation.

In working with these children, variety is not the spice of life! It is wise to have the same thing in the same order happen to the child each time. These children like and want to know what will happen and be able to predict it. Be sure and include experiences that you can share, and experience success together rather than for the child alone. They sometimes feel that if they experience a success alone that it is not believable or real. Continue to share experiences until you feel the child is ready to experience success on his own. This could be an extremely slow process so do not become discouraged.

Each tutor will go through much trial and error in his activities. This is to be expected. The fact that you are a stranger, when first working with the child, will probably mean that he will undoubtedly use every effort to control himself.

His behavior later may be quite different, once he has gotten to know you, and has tested the limits of the situation.

Any type of reinforcement that can be given by the tutor is important. When the child verbalizes, you can then help him understand what he is saying. Once he begins to understand and hear himself verbalize the reasons why he says he can't do something, then he may begin to try. Try to search more for the "how" and "why" than the "what" of an occurrence. The more you can analyze with the child what he has done, the better.

A valuable service you as a tutor can do for this type child is to help him develop a little more feeling of self-respect. Always build in a little time with the child when he is free to talk about anything on his mind. Don't probe, but give him casual opportunities to talk. Try to let him know that you understand and share his feelings.

Finally, one of the greatest services for a teacher that you a tutor can do is to actually find the level at which the child can have a continuing successful experience.

Information in this section has been adapted from a speech delivered by Dr. William Cruikshank, Director, Institute for Study of Mental Retardation, University of Michigan.

EDUCABLE RETARDED

The retarded child can learn, it just takes longer. As long as a volunteer keeps this in mind, he will succeed. Repetition is an important factor to remember in working with retarded children as well as children with perceptual handicaps.

The retarded child has special traits. Their learning experiences need to be altered to meet their specific needs. Because of the short attention spans of these children, and the unpredictability of their moods, it is extremely difficult, and not too wise to highly structure your sessions with the child. Don't set time limits for certain accomplishments, but rather move with the mood and the needs of the child being tutored. The important thing in working with the retarded child is not how quickly a subject can be presented, but how well he retains the material that has been presented. Gear the activities to each child's individual needs and abilities.

Films can be valuable in teaching the retarded child. A film with a story line involves them emotionally, holds their attention, and teaches desirable behavior. With repeated showings, fairly complex ideas can be taught.

BI-LINGUAL STUDENT

Tutoring Bi-lingual students primarily is in learning the English language. It is felt however that some attention to this should be mentioned, as science and mathematics is dependent upon language and can be incorporated in the tutoring sessions.

The following information has been adapted from the booklet, English as a Second Language, published by the Los Angeles City Schools, Division of Instructional Planning and Services.

One of the best ways for helping children learn the English language is involving them in the handling of materials. This could include the manipulating of puppets, arranging or using cutouts, and exploring textures, shapes, or colors. Other activities could include participation in dramatic presentations, and other activities where the tutee takes an active part. Bulletin boards and language masters are a use of media that can be most helpful.

The tutor of bi-lingual students has two roles. He can assist the classroom teacher with the preparation of materials for the pupil to use or aid in regular class activities. The tutor also can work with the child under either the direct or indirect supervision of the teacher. Lessons previously presented by the teacher are reinforced and enriched, thus giving assurance that the pupil has fully assimilated the instruction.

The following tips for tutors have been adapted from the above mentioned booklet:

1. Learn what can be expected from the boys and girls you work with in so far as their physical, mental, social, and emotional maturity is concerned. Remember that no one child will fit into any one level and that each pupil's maturity must be evaluated through first-hand observations.
2. Learn about your pupils' backgrounds. Boys and girls are not all the same, even though they may all be seated together learning English. Spanish-speaking boys and girls represent a wide socio-cultural range, as do pupils whose first language happens to be English.
3. Use gestures, pantomime, and a variety of facial expressions to aid the pupils in getting meaning from language.
4. Use the pupils' first language when you find they do not understand the instruction from clues that you provide through context, gestures, or props.
5. Be sure to allow "equal time" for each pupil. The timid one needs as much help, or possibly more, than the more aggressive pupil.
6. Speak to the boys and girls in a normal tone at normal speed. Let them do more talking than you do, for they need the practice.
7. Correct the pupil's pronunciation up to, but not beyond, his ability to profit from such correction. For example, if a child seems unable to pronounce the word yellow any differently than jello, even after several attempts at correction, let the matter pass, with a smile, for another time.

It is wise for the tutor to prepare his own kit of learning aids that may be used when working with the child. This could include items such as puppets, games, and cutouts. Games provide natural opportunities for children to both hear and speak English.



The volunteer should remember that pupils must have a good model to hear and to imitate. You are presenting yourself as such a model to the children and must be careful to speak distinctly and correctly. In doing this you are helping the student in his learning of the English language as well as the other subject material you are presenting.

Evaluation both by the tutor and a self-evaluation by the child can be most helpful. There are copies of both types that may be found on pages 176 and 177 to be reproduced by spirit master.

EMOTIONALLY AND SOCIALLY HANDICAPPED CHILD

The difference between the emotionally disturbed and the socially maladjusted child is that the emotionally disturbed child is maladjusted in relationship to himself; where the socially handicapped child is maladjusted in his relationship to others. These children very possibly could be found in other categories of handicapped children. For example, a child could be both aurally handicapped and emotionally handicapped. Many times these children will appear outwardly normal but their behavior obviously is abnormal.

Different characteristics of the emotionally disturbed child could be one or more of the following:

1. Hostility
2. Aggressiveness
3. Defiant behavior patterns
4. Overly passive
5. Accident prone
6. Frequently sick or complain of aches and pains, or fatigue

These children may suffer from deep-seated fears and frustrations caused by internal tension and conflict, guilt or anxieties. Though this child could be psychotic or neurotic, he does not necessarily behave antisocially.

The socially maladjusted child rarely is socially acceptable. They care nothing of others, and find it difficult to empathize with people. They often do not possess a set of values that is acceptable in our society. Since they have a restricted conscience they are limited in their feelings of guilt, or the ability to feel sorry. For these reasons, they do not have the same check on impulse and actions as the well-adjusted.

If at all possible it is preferable to keep these children in the regular classroom for the following reasons:

1. Many schools cannot afford to establish special classes.
2. The association with emotionally and socially well-adjusted children is important.
3. If they were educated elsewhere, an atypical setting could make their rehabilitation more difficult.

In working with these children, the volunteer should know as much as possible about mental health, and should develop a real empathy toward children with problems. If possible, maintain a close relationship that is both sympathetic and supportive to the parents. It is extremely important that every opportunity be used to help the child improve his self-concept. If problems arise for the tutor with this type of handicapped child, immediately inform the teacher, who in turn will assess the situation to decide if professional help is needed.

GIFTED AND CREATIVE CHILDREN

Gifted and creative children are not categorized as handicapped children, unless there is an absence of educational opportunities available to them. A new report to Congress from the U.S. Office of Education documents a "widespread neglect of gifted and talented children" which has become a "universal, increasing problem". This neglect results in a tragic waste of human and national resources. In a comprehensive study, required by the Elementary and Secondary Education Amendments of 1969, it was concluded that special programs for gifted children "can and do produce significant and measurable outcomes", but these programs have reached very few students in the past 50 years, especially among the disadvantaged and minority groups. The major obstacle to programs for the gifted include a lack of funds and a shortage of trained teachers. The report further states, "Contrary to widespread belief, these students cannot ordinarily excel without assistance". Unless there is someone to assist in motivating them, they become bored, dissatisfied and "perform far below their intellectual potential". The volunteer can offer a most valuable role in enrichment and expansion of subjects, to extend the classroom teachers' teaching.

Education USA, published by National School Public Relations Association, in previewing an article from Today's Education, states that, "Creative children are handicapped by their creativeness and are often diagnosed as having learning disabilities. Because creative children prefer to learn by questioning and experimenting rather than from an authority, gifted children may fail to learn altogether in the average school and be relegated to a circle of 'hopeless children' in the rear of the room." Resourceful and well-trained volunteers can challenge the creativity of these children.

ENRICHMENT

*The more you give, the more you get.
The more you laugh, the less you fret.
The more you do unselfishly,
The more you live abundantly.
The more of everything you share,
The more you'll always have to spare.
For only what you give away
Enriches you from day to day.*

Hazel Cox

Tactile Mystery Box

This game can be played by a small group or a whole class. The purpose is to identify an object by touching and then asking questions about the objects nature and use.

Materials needed: A shoe box with circular holes cut through each end. The openings must be large enough so that the child's hand can be placed inside the box. Different materials such as paper clips, thumb tacks, wet sponge, a piece of cloth, a piece of chalk, pencil, marbles, sandpaper.

Directions: The child who is chosen as "it" leaves the room. The rest of the children then select the object to be placed into the box. The child then returns to the room and sits before the class with the box on his lap, and places his hands in the holes, feeling the object. He then tells the group how the object feels, and can ask them questions that they can answer "yes" or "no" to, to help him identify the object. At the end of a specified time the child must try to identify what is in the box. He then chooses the next person to leave the room. This could also be played with competing teams and keeping score. The children also could bring items to be used in the box.

What is it?

Materials: Paper bag and different types of material such as silk, satin, corduroy, wool, cotton, rubber, leather, cardboard, paper napkins.

Directions: The teacher places material in the bag. The group is divided up into two teams. A member of one team feels the item in the bag and then gives a description to his teammates. If the material is not identified after five tries, the opposing team gets one guess. Whichever team identifies the material receives one point. The object is to see which team receives the most points.

Sandpaper Numbers

Cut large numbers from sandpaper and reinforce with cardboard, oak-tag or styrofoam, binding the edges together with a good plastic tape. Also make the arithmetic symbols so that the children may work problems with these. Games could be devised, with each child having his own set of numbers that he has made. The teacher can arrange a problem with the numbers for each child and see which child "finds" his answer first. This would need to be done with a very small group of children. The children are not allowed to feel his problem until the teacher arranges each child's problem. This also could be done in teams with more children involved, each child taking a turn.

Tracing numbers in a sand box is another fun way to learn simple number problems. This could be very helpful to a child who is hard of hearing or deaf. Have the children write the numbers three times while he is looking at the word on the blackboard. Then have the child write the number on paper or the blackboard. Also have the child tap out the number before he draws it in the sand.

Another similar method would be for each child to have his own personal box with his name on the side of the box. Instead of filling these with sand, salt could be used. This could become an activity with each child making his own. He could then have this for his own use, by taking it home.

GAMES AND ACTIVITIES

Sound - What's in the Box?

This game can be played with as few or as many children as desired. If played with a number of children, they should be divided into teams.

Materials: Any type of a carton with a lid. Each child should have his own carton. Different types of objects to place in the cartons. Each child needs masking tape to seal the box.

Directions: The children exchange boxes. They then take turns making first observation, then inferences, and finally attempting to identify the object.

The comments could go something like this:

Observations: object rolls freely
sounds dull
small object

Inferences: object is round
could be glass or wood

Object: a marble

Children could bring objects from home. This is excellent drill in developing acute listening habits, particularly helpful for the blind. It also is a good exercise when studying the five senses in science, as an example of the sense of sound.

Sight

Make a large chart for a bulletin board as follows:

SEE	SMELL	HEAR	TASTE	FEEL

The children add pictures to the chart in the most appropriate spot. For variety this could be done during different seasons of the year, using pictures that depict the current season.

GLOSSARY OF TERMS COMMONLY USED WITH HANDICAPPED

Anomaly	Irregularity
Anterior	Situated in front
Arthritis	Inflamation of a joint
Ataxia	Loss of muscular coordination. Persons often stagger when they walk.
Athetoid	Muscles are normal but make involuntary, purposeless movements. Lacks ability to direct his lips, tongue, extremities or trunk in a desired motion.
Atrophy	Wasting of body tissues
Bilateral	Pertaining to two sides
Brachial Palsy	Paralysis of the muscles of the upper extremity due to a nerve injury. There may be some loss of function in the muscles controlled by the nerves that are injured. There may be shortening of the affected arm but little limitation in use.
Cerebral Palsy	A neuro-muscular disability caused by injury to the motor centers of the brain. Most cases are caused by damage to the brain, either during or before birth, or by incomplete development of the brain cells. There is a possibility that, after birth, accidents involving the brain, sleeping sickness, or meningitis may also damage the brain and result in cerebral palsy. There are five general types of cerebral palsy: Spastic, Athetoid, Ataxia, Tremor, and Rigidity.
Club Foot	One of the most common congenital irregularities. The foot is rotated inward and the Achilles tendon is always shortened with the heel drawn up. With early treatment, there is an excellent chance that the deformity will be completely corrected.
Congenital	Existing at birth
Contracture	A shortening or drawing together
Diabetes	Disease involving the inability of the body to regulate sugar metabolism. This is an often inherited disease, which is less common in children than among adults. It is more difficult to control in children, part of the reason being that the child does not always recognize the importance of the disease, and will not adhere to his dietary restrictions. Any signs of excessive perspiration, dizziness, agitation, headache and unconsciousness should be reported immediately so that

the child can have his urine checked and medical attention. Such signs might indicate too much or too little insulin.

Digits	Fingers or toes
Embryonic	Pertaining to the fetus, or unborn offspring
Etiology	Cause of disease
Eversion	Turning outward
Fracture	Break
Fusion	Coherence of adjacent parts
Hemiplegia	Paralysis of an arm and leg on the same side
Hemophilia	Usually an inherited blood disorder involving a tendency to bleed excessively. Minor cuts and scratches may bleed sufficiently to require a transfusion. Injuries to joints and soft tissues may cause a hemorrhage into these areas with severe pain and swelling. If this happens, the patient should be placed at rest, immobilized and ice packs applied to the involved area until medical treatment is available.
Idiopathic	Self-originated - no known cause
Inversion	Turning inward or reversal of normal relation
Lateral	Pertaining to a side
Lesion	Any hurt, wound, or local degeneration
Mobilize	To render a fixed part movable
Multiple Sclerosis	This is probably the most common of the degenerative diseases of the nervous system. It affects chiefly young adults and may occur in the form of attacks or as a slowly progressive disease. Common symptoms are spastic weakness of arms and legs, blindness, double vision, staggering, tremors, incontinence of urine and pain. The manifestations of the disease are the result of peculiar lesions scattered throughout the brain and spinal cord. In many cases the symptoms are progressive and permanent. The weakness is spastic in origin; that is, that the muscles are out of control rather than partially disconnected from the nervous system. Certain groups of muscles have become relatively more powerful than their opponents, because of the over-active reflexes.
Muscular Dystrophy	This is a chronic, non-contagious, progressive disease manifested by weakness and wasting of the voluntary muscles with eventual involvement of the entire muscle system. The cause is unknown. The symptoms are: constant falling, difficulty in ascending stairs, a peculiar side-to-side waddling gait, great difficulty in rising from a lying or sitting position to a standing position. Young boys,

particularly, are prone to tightness of the muscles and tendons. These children are rather difficult to pick up. When attempting to lift a child with muscular dystrophy under the arms, these children often slip through the hands of the person lifting them. Caution should be taken along these lines.

Orthopedics	Science of straightening deformities
Ossification	Growth of bone
Osteogenesis Imperfecta	A congenital disease marked by fragility of bone
Osteomyelitis	An infection of the bone
Over Correction	Placing in an exaggeration of the correct position
Paraplegia	Paralysis of both lower extremities
Pathological	Relating to material change in the body as a result of disease or injury
Physiological	Pertaining to the functions of the body organs
Physiotherapy	The use of natural forces, such as light, heat, air, water and exercise in the treatment
Poliomyelitis	(Polio) Infantile paralysis is known to be caused by a virus that has an affinity for certain nerve cells of the brain and spinal cord. Polio can be considered as a disease of the spinal and central nervous system, rather than primarily a disease of the muscle. Muscles controlled by nerve cells that have been killed by the virus, will be in a paralyzed state. If the nerve cells are not too badly injured, they often recover and re-establish the pathway from brain to muscle.
Posterior	Situated behind or at the rear
Pott's Disease	Tuberculosis of the vertebral column
Quadriplegia	Paralysis of four limbs and trunk - also used for palsy for four limbs, head and trunk
Rigidity	Muscles are stiff, but not tense. If pushed over, the person's muscles would not contract in a protective manner.
Rheumatic Fever	An illness with inflammation of the joints, blood vessels and especially the heart. It follows a sore throat due to a specific streptococcal bacteria. It starts as a disease of childhood but may occur in adult life. Tonsillitis, pallor, fatigue, nose bleeds, abdominal

pain and joint pain, alone or in combination, are common. Usually one or more of the body's larger joints become swollen, red, and painful. Extreme nervousness and speech trouble, alone or with the other symptoms, may occur primarily in girls.

Sclerosis	Hardening
Scoliosis	Curvature of the spine
Spastic	Characterized by spasms. When muscles are moved they contract and prevent the intended movement. This causes stiffness in the muscle. Movements are stiff and jerky and uncertain.
Spina Bifida	A congenital defect in the development of the spine. The defect may occur in any part of the spine, but more frequently it is found in the lumbar-sacral region. A gap may occur in the posterior vertebral wall through which there is a protrusion of the spinal membranes or cord or both. All motor and sensory neurons below the level of the defect are involved and there may be complete or partial paralysis of the lower extremities and loss of sensation. Loss of bowel and bladder control may also occur. With the loss of sensation, these individuals cannot differentiate between temperature, and do not feel friction of braces, chafing, and other skin irritants. Care should be stressed in avoiding too hot water, or other sources of heat.
Static	Fixed
Still's Disease	Chronic arthritis of childhood
Symptomatic	Pertaining to symptoms
Traction	The act of drawing or pulling
Trauma	Wound or injury
Tumor	A swelling or growth (abnormal) not due to inflammation
Unilateral	Pertaining to one side

FOR BI-LINGUAL STUDENTS

NAME _____

AGE _____

GRADE _____

PUPIL CHECK LIST

ITEM	Little Improvement	Fair Improvement	Good Improvement	Excellent Improvement
Listens with interest				
Listens with accuracy				
Understands directions				
Understands concepts				
Understands multi-media materials				
Recalls subject material accurately				
Repeats vocabulary words accurately				
Spontaneously uses language in relation to subject				

Adapted from
English as a Second Language
Los Angeles City Schools

FOR BI-LINGUAL STUDENTS

TUTOR SELF EVALUATION

ITEM	FREQUENCY		
	Occasionally	Frequently	Always
Do I			
<u>Prepare carefully?</u>			
<u>Demonstrate enthusiasm?</u>			
<u>Provide for individual differences?</u>			
<u>Use a variety of materials?</u>			
<u>Invent new activities and games?</u>			
<u>Read professional reports?</u>			
Do boys and girls with whom I work			
<u>Attend class regularly?</u>			
<u>Show enthusiasm?</u>			
<u>Participate willingly?</u>			
<u>Continue to understand more English?</u>			
<u>Continue to use more English?</u>			

THE TUTOR'S ROLE

STAFF-VOLUNTEER RELATIONSHIPS

Tutoring is essentially an individual experience; an interrelationship of two individuals, the tutor and the student, working closely together, under the supervision of the teacher. In this relationship there is no one method, no easy answer. The teacher utilizes his professional training to diagnose the problem of the student and to prescribe the correct procedure to be followed by the volunteer. The volunteer will find the most successful methods as they are developed while working with the student. It is important to maintain a close relationship with the teacher, so that you are following the prescription and working with the curriculum, as designated by the school. The curriculum is as varied, from school to school, as the individuality of each student.

The purpose of tutoring is -

- to improve the educational achievement of the student
- to enhance the student's picture of himself and to increase his life experience
- to widen the horizons of the student through the enrichment of a contact with another concerned, helpful, friendly person.



Tutoring is not teaching, but simply provides the assistance and support which a concerned parent can and often does provide. Experienced educators agree that those not trained for teaching often can change a student's value of himself and his attitude through effective and correct tutoring. The new style of elementary instruction that now is designated as "open classrooms" or "informal education" and the concept of team teaching has created a further role for the volunteer, in reinforcing individualized instruction. The joy of learning may be amplified through a volunteer's gift of pleasure in creating, and can relieve the teacher of the tremendous load of each day's tasks.

In the San Francisco Education Auxiliary handbook for teachers, it is stated, "Working with a volunteer is a dialogue: it means two people interacting. It means two people working together toward a common goal. It means mutual respect, give and take, cooperation, mutual learning. Only through this kind of experience can the teacher and volunteer function as an effective team for better education."

In Chapter IV on Mathematics Tutoring, suggestions are made as to how to build and reinforce a child's self-image, and ideas for building and maintaining his interest. For additional understanding of the child and how to build a relationship, see "Guidelines for the Volunteer Tutor", compiled by Project MOTIVATE, Des Moines Area Community College.

To create better understanding between volunteers and staff in the schools, guidelines should cooperatively be established as to the role of each. The following are suggestions to be considered in developing these, and upon completion and approval by administrative and teaching staff, volunteer coordinators, and administrative and service volunteers, the statements should be printed, to be used for teachers and volunteers' orientation and distribution to all.

HOW TO CREATE BETTER UNDERSTANDING BETWEEN SCHOOL VOLUNTEERS AND SCHOOL STAFF¹

- Keep lines of communication open so that problems can be talked about before resentments build up.
- Be certain placement is mutually satisfactory to volunteer and staff.
- Have informal get-togethers to discuss mutual concerns.
- Explain that criticism of staff or volunteer by either will not improve education.
- Talk to each volunteer separately to learn about their feelings and problems and build a continuing communication.
- Be certain that volunteers understand school staff responsibilities.
- Hold joint staff and volunteer meetings often enough to give them a chance to get to know each other's point of view; encourage and facilitate talking about problems they are experiencing, in working together.
- Keep an open mind.
- Utilize volunteer's job description for both staff and volunteer orientation, so that duties may be understood by all.
- Combine recruitment of volunteer with honest orientation that staff needs their help; if they are recruited under false pretenses, they may resent having a job turned over to them for which they believe staff is "getting paid - I'm not".
- Reiterate constantly the role of the staff and the role of volunteer in your school, in initial orientation and in training sessions.
- Have both volunteers and staff mutually draw up procedures for joint functions.
- Have school staff prepare information concerning their role in the volunteer program, and their valuation of the volunteer as their service relates to the student.
- Try to have more school staff at volunteer training sessions; they usually don't attend because time isn't budgeted for this. Utilize as many as possible as trainers.
- Have school staff explore ways they can use volunteer assistance; help them see that the volunteer can be of substantial help in supplying supplemental and supportive services.
- Conduct orientation programs for school staff on "How To Work With Volunteers", indicating for example, that volunteers generally can't be expected to keep the same hours (8:00 AM!!) as staff, etc.
- Have school staff cooperate in giving recognition to volunteers, thereby showing a real interest in the job being performed by the volunteers.
- Get them acquainted on a social basis. The friendly chat and cup of coffee can work wonders. Make the staff aware of the fact that volunteers are people too.
- Permit volunteers to know and help all of the staff.
- Provide staff and volunteers opportunity to cooperatively bring about desirable changes, within school policies.

¹ Adapted from materials from Los Angeles, California, SCHOOL VOLUNTEER PROGRAM

Create situations for mutual responsibilities.

Orientation of staff is as important as orientation of the volunteer about the entire program. Each new staff member must be educated about utilization of volunteers immediately. If job descriptions are carefully outlined, the paid staff will know the volunteer isn't there to take over. Clerical staff needs as much preparation as professional staff -- indeed, perhaps more as experience indicates that too often the treatment given volunteers by clerical staff is far from good.

Develop positive attitude in all team members.

HOW TO CONVINCING THE STAFF THE VOLUNTEER IS NOT A THREAT

Explain to the staff that the volunteers' services are to augment staff services, and NOT to replace them. It can be helpful to point out those school needs which are not being met by staff, and talk in terms of the assistance a volunteer might give the staff in meeting these needs.

Help staff analyze their attitude toward having an adult "outsider" in their class.

Make the staff see how much more they can do if freed of some of the menial and time-consuming tasks which are appropriate for volunteers to do.

Assure school staff that administration is willing to listen and act upon their complaints about volunteers.

Explain that in most cases a volunteer is a threat only if he is not properly oriented or does not understand his role and the role of the staff member.

This is a problem of personal relationship.

Meet with staff and share with them the "why and wherefores" of the volunteer program.

Meet periodically with school staff and interpret the work volunteers are doing.

Help staff to recognize volunteers' strengths and improve the weaknesses.

Help school staff understand the role of citizens who support public schools and the importance of this community support.

Build the ego of the school staff so they are self-assured enough not to be threatened.

Explain that leading is accomplished through generating cooperation.

Let the volunteer's services to the student convince the staff of their worth.

Be sure school staff knows something about volunteering and volunteers. It would be wonderful if each staff person had to do some volunteer work in another agency, just to experience the way a volunteer feels.

If the staff member is not convinced that volunteers can help, before they are introduced into the program, he will need to have the experience of working with and through a volunteer before becoming convinced. Talking with colleagues may help the staff to "try", but only working with volunteers will truly convince staff that help from a volunteer is a way to help him do what needs to be done.

Have staff assist in defining the rights and privileges of volunteers.

By conviction and enthusiasm of school principals for the volunteer program, and by using staff to supervise and direct volunteers.

Outline job descriptions specifically as to who does what, how, when and why.

Involve school staff cooperatively in planning.

HOW TO KEEP THE SCHOOL VOLUNTEERS FROM ASSUMING STAFF RESPONSIBILITIES

- Watch for early indications of this happening, and transfer the volunteer's activity to something which will continue to give responsibility and satisfaction, but not allow take-over.
- Be definite on limits of volunteer's job and the school staff duties.
- Clearly define the chain of command, and stress the necessity of observing it, during orientation and placement.
- Make the differentiation early and FIRMLY.
- Provide careful and specific orientation and training as to regulations and procedures of school and provide for joint meetings of volunteers and staff.
- By keeping communication open.
- Establish an initial meeting for both volunteers and school staff, wherein each would have the opportunity to discuss expectations, limitations, and roles to be assumed.
- Formulate clear, definite job descriptions for volunteers, IN WRITING, and reviewed and revised as needed from time to time.

HOW TO CONVINCe STAFF THAT THERE MAY BE TIMES WHEN THE VOLUNTEER SHOULD ASSUME FULL RESPONSIBILITY FOR A JOB

- Assure school staff that volunteer has experience and knowledge of the job, particularly if volunteer has more experience or expertise than the staff, in a particular area.
- The staff person in charge must be secure enough to relinquish his authority to a volunteer in certain situations without feeling threatened. Many schools involve volunteers in various projects in which they have a special talent or interest. This supplements the classroom offerings of the teacher, and enriches program for the children.
- Give the school staff proper training in the utilization of volunteers.
- Explain the volunteer's qualifications.
- Show school staff examples of situations which are appropriate for the volunteers to handle alone.
- Use areas of competence as a basis for letting volunteers take responsibility.
- If a volunteer is to be used to his full potential, he MUST be allowed to take responsibility when appropriate. Sometimes they must make mistakes in order to learn.
- Assure school staff that this will release them for more important activities.
- Have "brain-storming" sessions with school staff as to what creative, new things the volunteers could be doing.
- School staff members should never forget that ideally, school work is a partnership between staff and volunteers -- that the volunteers are the experts in some areas and the staff, experts in others.

If a volunteer understands and accepts the following Prescription, as developed by the Cleveland Public Schools, many problems will be avoided and good relationship will develop and be maintained between volunteers and staff in school programs.

PRESCRIPTION FOR TUTORING

THREE R'S FOR THE VOLUNTEER

In accepting the assignment as a VOLUNTEER tutor, you have indicated your desire to support the instructional efforts of the elementary school by providing a useful, auxiliary service.

The following three "R's" will support and guide you throughout your experience as a VOLUNTEER.

- RESPONSIBILITY

The effective VOLUNTEER

- is regular in attendance.
- is appreciative of the efforts of the school to educate all children.
- is cooperative with administrative and teaching personnel.
- is aware of the importance of planning each tutoring session.
- is sincerely concerned about the pupil who is being tutored.
- is able to generate enthusiasm about each child and his potential.

- RAPPORT

The understanding VOLUNTEER

- recognizes the child's need to improve his self-image.
- supports the child by offering genuine friendship.
- provides a relaxed, friendly atmosphere for tutoring sessions.
- provides many opportunities for the child to be successful.

- REWARDS

The successful VOLUNTEER

- shares with the child the warm personal satisfactions which result from successful human relationships.
- provides the teacher with the satisfaction of knowing that the child's needs are being met.
- receives the sincere gratitude of the entire school community.

Follow the three "R's" and become an effective, understanding, successful VOLUNTEER.

DIVISION OF RESPONSIBILITY OF SCHOOL VOLUNTEER PROGRAM (SVP) PERSONNEL

The VOLUNTEERS shall:

- Understand motivation and attitudes for service.
- Attend orientation and training sessions.
- Volunteer a minimum of (time) a week for the school.
- Arrange for a substitute with the approval of the school coordinator.
- Have materials and ideas ready and activities planned.
- Complete evaluation reports and records.
- Maintain communication with the teachers and school chairman, and provide information as needed by the SVP coordinator.
- Respect confidentiality of educational principles and processes of the school, and of students' abilities and progress.
- Be willing to receive constructive criticism.
- Take required health tests.
- Be dependable, flexible, and willing to be a team partner.
- Be willing to be reassigned, when placement is not mutually acceptable or when a particular child has achieved the prescribed goal.

The SCHOOL VOLUNTEER CHAIRMAN shall:

- Establish volunteers' service schedules with the principal or other school representative.
- Interview volunteers and recommend placement.
- Arrange for substitutes when needed.
- Learn school procedures, policies and location of materials.
- Work as liaison person between volunteers and school administrators.
- Work as liaison person between volunteers and the SVP coordinator.
- Assist in on-going and formal recognition for volunteers.

The TEACHERS shall:

- Define the need for the volunteer and understand their role.
- Request a service or resource volunteer.
- Plan for tasks to be performed by volunteer and provide instructions, rules, procedures, and materials.
- Identify children to be tutored.
- Designate if student is assigned to volunteer for social adjustment and/or reinforcement of academic skills.
- Develop a schedule for communication with the volunteer to discuss the child and helpful techniques.
- Identify areas in which child needs help and provide prescription for assistance.
- Approve of volunteer assignment.
- Attend orientation and training on how to work with volunteers.
- Be responsible for the instruction, discipline and safety of students, and for content and techniques of instruction.
- Evaluate results of assignments with the volunteer.

The PRINCIPAL shall:

- Identify tutorial stations in school and provide other needed space for volunteers and their materials.
- Explain and interpret the purpose of the volunteer program to staff and community.

Secure parental permission for child to participate in program if it is deemed necessary.
Approve volunteer's placement.
Notify the SVP coordinator and the school chairman if volunteer should prove unsatisfactory.
See that some kind of recognition is planned for administrative, service and resource volunteers.

The SVP COORDINATOR shall:

Give initial interview and placement.
Develop the basic orientation program for the volunteers.
Provide staff service to the SVP Advisory Board and committees.
Work with the SVP Advisory Board and school chairmen in the overall direction of the program.
Consult with principals or other designated staff before and during the time volunteers go into service in each school.
Contact the school periodically to ascertain whether everything is progressing satisfactorily.
Aid the school chairman in planning periodic meetings of all volunteers in each school. These meetings shall provide further training for volunteers and/or informational exchanges.
Keep a file indicating names, addresses, phone numbers and other records and pertinent data about the volunteers.
Reassign volunteers when necessary.
Distribute a periodic newsletter for all volunteers.
Supervise and coordinate the research and evaluation of the program.
Plan and develop criteria for recognition for volunteers.

JOB DESCRIPTIONS

To enable each team member to function within their own division of responsibility, it is important to prepare a job description for each category of service needed. In reality, volunteers are unpaid members of the staff, and as such, should have the same rights and responsibilities of paid staff, and be expected to fulfill the duties for which they have expressed a commitment and willingness to perform.

Each phase of the volunteer program is dependent upon a job description, whether you are recruiting, interviewing, referring, orienting, recognizing, or evaluating. The content of the job description should include -

type of work
purpose
place of work
hours required
duties
duration of job
qualifications, such as education, training, experience, age, health, dress, when applicable
orientation and training required
responsible to whom
other special requirements

A volunteer can not satisfactorily be recruited unless specifications have been developed detailing his responsibilities. How can you ask someone to help you if you have not identified why, where, when and how you need them? The job description is used at the time of the interview to answer these questions, and the resulting answers determines an assignment suited to the need. Upon placement, this completed job description and application should go into their "employment" file, just as any other personnel in the school. This written outline of duties gives the volunteer a sense of security and emphasizes the need for their help. It is the mirror of the school volunteer program and separates responsibilities of paid staff, supervisory volunteers and service volunteers, so there is no overlap or misunderstandings. Each person has an assignment and with a line of reportability and accountability, and communication is outlined. Standards for the job are established, and volunteers are shown that the program expects them to meet these standards. Training should be outlined to relate to the purpose of the task, and duties required, and the supervisor performs according to these requirements. It is especially helpful to a new supervisor or chairman to understand their role and know what is expected of each volunteer. The volunteer's performance may be evaluated according to the job description, and promotion and recognition planned according to how the performance measures up to the requirements.

Suggested job descriptions are given on the following pages, and variations should be made according to school policies, and the size and structure of the system.

**YOU
CAN
HELP
WORK
FREE**

SAMPLE JOB DESCRIPTION

Job Title: Director, Supervisor or Coordinator, School Volunteer Program

Job Objective: To organize, develop and direct a program of voluntary citizen participation, within and/or outside of the schools, to strengthen the school program and to enrich a student's educational experience.

Accountability: Responsible to administration of school board and to the School Volunteer Program advisory committee, whose policies and programs establish the purpose and operation of the School Volunteer Program.

Function: Assist the advisory committee with organization and administration of School Volunteer Program activities in a community-wide effort to recruit, interview, inform, recognize and refer volunteers to those schools requesting volunteers.

Interpret teachers' requests for volunteers.

Maintain working knowledge of each school's programs, their volunteer requirements and the way volunteers serve in the schools.

Provide consultation and resources to schools in establishing and strengthening their volunteer program.

Interpret need for citizen participation through development of resources and materials to promote volunteerism.

Assume administrative duties as follows:

Provide advisory committee with factual information and ideas which might be of assistance in their deliberations and policy decisions.

Work with all committee chairmen to develop plans and procedures for their functions; be available to all committees, supplying information and assistance as needed.

Perform direct administrative tasks at the request of the chairman of the advisory committee.

Prepare budget for submission to advisory committee and administer finances.

Prepare other staff to work with volunteers.

Prepare periodic and annual reports, cooperatively with advisory committee.

Supervise paid and volunteer personnel.

Devise and revise forms necessary for service operation.

Provide communication and understanding between volunteers and staff.

Create and maintain materials and supplies for volunteer's use.

Provide over-all coordination of program in cooperation with advisory committee, as follows:

Survey teachers to establish and interpret their need for volunteer assistance.

Plan techniques and develop resources to recruit volunteers.

Develop job description for each volunteer assignment.

Interview volunteers and make appropriate job assignments.

Develop orientation program and in-service training for volunteers and teachers.

Provide manual of School Volunteer Program.

Prepare promotion materials for program and plan for material distribution.

Maintain complete records of all volunteer activities and tabulate for useful evaluation purposes.

Supervise and coordinate the research and evaluation of the program.
Provide continuing supervision, motivation and counseling to volunteers,
and handle grievances correctly.
Provide volunteers with adequate facilities and materials for their work,
complete guidelines for job and fringe benefits when possible.
Provide on-going and special recognition for volunteers' services.
Seek resources for new helpful ideas to improve the program.
Meet and consult with other professionals in the field of volunteer services
to discuss problems, concerns and matters of mutual interest; be willing
to seek and accept job training. Represent School Volunteer Program in
community meetings and activities.

Qualifications:

- a. Training and experience - College degree or its equivalent in experience,
with focus on the understanding of human behavior and the social services.
Training in personnel administration and general knowledge of standard office
procedures desirable. Previous experience in working with public. Previous
experience as a volunteer in service and administrative areas.
- b. Knowledge, ability and skills - Be familiar with the community and its
resources. Have understanding and compassion for the needs of children.
Ability to effectively communicate with other professionals, the public,
and volunteers. Ability to plan work ahead, to handle discipline of
volunteers, to explain "why" of jobs, to get loyalty, to get teamwork,
to work under pressure, to accept criticism, to get work done, to maintain
quality, to make decisions, to organize time, to motivate volunteers, to
encourage creative ideas, to work with superiors, to delegate effectively.
- c. Other - good health, availability to travel if requirement of job, automobile,
suitable age, etc.

Terms of Employment: Salary, vacation, sick leave, fringe benefits, termination
of employment and other personnel policies usually are determined by policies of
personnel department.

Evaluation of Performance: Criteria should be developed by personnel department
to effectively evaluate the employee's performance.

*Project MOTIVATE
Des Moines Area Community College
Ankeny, Iowa*

SAMPLE JOB DESCRIPTION

Job Title: Staff Representative

Job Objective: To act as liaison between professional staff (principal, teachers, librarians, nurse, etc.) of the school and the volunteer coordinator and volunteers in the school, to develop and maintain an understanding of the goals, philosophy and mechanics of the program. It is desirable that staff representative attend a basic orientation to secure this knowledge.

Accountability: Responsible to school principal.

Function: Acquaint professional staff with the volunteer program:

- 1) Goals, philosophy, and policies
- 2) Type of training given to volunteers
- 3) Services available from volunteers
- 4) How to request volunteer help
- 5) Tips and techniques to effectively utilize services and supervise volunteers
- 6) How to evaluate service
- 7) Need for their support
- 8) How to appreciate volunteer and provide recognition.

Introduce volunteers to staff.

Assist in securing names of pupils recommended for assistance by volunteer.

Secure names of teachers interested in non-clerical classroom assistance.

Assign and schedule volunteers (may be responsibility of school volunteer chairman).

Determine place where volunteer and student will work.

Provide materials for volunteers:

- 1) General supplies: pencils, paper, notebook, etc.
- 2) Appropriate reading, math, or science books, games, etc.
- 3) Multi media materials and equipment.

Designate space for Volunteer Materials Center.

Orient volunteers to school by acquainting them with:

- 1) Physical arrangement of school
- 2) Location of Volunteer Materials Center
- 3) School regulations (fire drill, liability, etc.)

Notify volunteer chairman of:

- 1) Changes in school schedule
- 2) School holidays

Arrange periodic conferences between volunteers and teachers as needed.

Act as consultant to volunteer group by conducting periodic in-service meetings to:

- 1) Discuss concerns
- 2) Acquaint volunteers with new materials available for their use
- 3) Explain professional jargon
- 4) Discuss additional ideas and/or techniques for meeting needs of students.

Duration of Job: One year, minimum.

Qualifications: May be principal, reading adjustment teacher, counselor, consultant or teacher who can be allocated sufficient time to serve in this capacity. Ability to relate to staff and volunteers.

SAMPLE JOB DESCRIPTION

Type of Work: School Volunteer Chairman (or Coordinator).

Purpose: To act as liaison between professional staff of school, staff representative and volunteers in the school to maintain a well coordinated School Volunteer Program (SVP).

Place of Work: In school and at home.

Hours: 2 hours, 3 times per week minimum.

Duties: Help in volunteer recruitment.
Arrange for initial meeting of volunteer and staff representative to discuss and schedule initial assignments.
Enlist support of neighborhood agencies and publications.
Keep files and records of volunteer activities in school and relay records to SVP Coordinator.
Secure volunteer's application, conduct interview, discuss job description and assign volunteer.
Process teacher request for volunteer aid.
Confer with principal and staff when necessary.
Orient volunteers to school situation.
Provide in-service training to volunteers for special areas, such as reading or math tutor, library aide, etc.
Maintain materials and supplies for volunteers.
Identify volunteers for positions of greater responsibility within total SVP.
Assist staff in effective use of volunteers.
Determine need for workshop and in-service training to increase volunteer's capacity to serve.
Plan meetings for volunteers for exchange of ideas and problem solving.
Encourage creative ideas.
Arrange for substitutes when volunteer must be absent.
Arrange for recognition of volunteer service.
Supervise volunteers.
Motivate volunteers to excellence and develop leaders.
Maintain regular communication with SVP Coordinator.

Duration of Job: One year, minimum.

Volunteer Qualifications: No educational requirements. Experience as a school volunteer desirable. Enthusiasm, understanding of needs and problems of people.

Ability to explain "why" of jobs.
Ability to make decisions.
Ability to delegate effectively.
Ability to get teamwork and loyalty.

Orientation and Training: Six hour orientation on basics of recruitment, interview, placement, supervision, recognition, record keeping and evaluation required. In-service training as designed by SVP.

Responsible to: Principal of school and SVP Coordinator.

*Project MOTIVATE
Des Moines Area Community College
Ankeny, Iowa*

SAMPLE JOB DESCRIPTION

Type of Work: Science Tutor and Assistant

Purpose: To provide a child in science classes with a sense of reinforcement, through a one-to-one relationship and additional close personal attention as an instructional aide; to improve a child's self image; and to widen horizons of child.

Place of Work: In school classroom or in a designated place, as assigned by principal or staff representative.

Hours: Minimum, once a week, for two hours, regularly and punctually.

Duration of Job: Until end of school year.

Duties: Under the direction and guidance of the teacher, the following may be performed: Provide encouragement and support as a friend by:

- 1) Helping child to develop positive self concept and self worth by complimenting him on his appearance, his thinking, and his school work.
- 2) Showing acceptance of child by listening to what he has to say, demonstrating personal concern.
- 3) Helping child develop an inquisitive, inventive and imaginative attitude of exploration and discovery in scientific concepts.
- 4) Encouraging child to continue to respond to difficult materials by being receptive rather than berating him for his mistakes, and building on his success.
- 5) Providing the child with time to think things through himself.
- 6) Assisting child in scientific excursions with special experiments, to extend their learning.

Give child activities, games or experiments made up just for him alone.
Review with child the work that teacher has given to the whole class.
Assist teacher with preparation of laboratory materials.

Volunteer Qualifications: Good health; willingness to take recommended health tests, i.e. TB.

Dependable and prompt.

Interest in children and ability to relate to them; compatible to their needs.

Respect for confidentiality.

Education - no limitations.

Flexible, friendly, patient and optimistic.

Sense of humor.

Dress - appropriate and comfortable for participation in child's activities.

Natural curiosity, creativity and resourcefulness is helpful.

Ability to give a gift of encouragement.

Orientation and Training: Two hours basic training to the school and its volunteer program. Twelve hours training in tutoring science.

Responsible to: School chairman, teacher and principal.

*Project MOTIVATE
Des Moines Area Community College
Ankeny, Iowa*

SAMPLE JOB DESCRIPTION

Type of Work: Mathematics Tutor

Purpose: To provide a child who has trouble in mathematics with a sense of reinforcement, through a one-to-one relationship and additional close personal attention as an instructional aide; to improve a child's self image; and to widen horizons in the world of numbers for a child.

Place of Work: In school classroom or in a designated place, as assigned by principal or staff representative; or in a tutoring center established in a church, community center or other facility.

Hours: Minimum, once a week, for one hour, regularly and punctually.

Duration of Job: Until end of school year, or until child has attained satisfactory level of achievement, as designated by teacher.

Duties: Under the direction and guidance of the teacher, the following may be performed: Provide encouragement and support as a friend by:

- 1) Getting acquainted and understanding child's comprehension of math.
- 2) Helping child to develop positive self concept and self worth by complimenting him on his appearance, his thinking, and his school work.
- 3) Showing acceptance of child by listening to what he has to say, demonstrating personal concern.
- 4) Helping child develop positive attitude toward learning, by giving him variations of learning tasks he is able to perform and positive emotional support.
- 5) Encouraging child to continue to respond to difficult materials by being receptive rather than berating him for his mistakes, and building on his success.
- 6) Understanding reasons why child is having difficulties in mathematics.

Give child special challenging experiences, planned just for him alone.

Review with child the work that teacher has given to the whole class.

Use concrete aids, such as sticks, squared paper, number lines, groups of same kinds of objects, games, and audio and visual aids.

Evaluate performance.

Volunteer Qualifications: Good health; agreeable to take required health tests.

Dependable and prompt.

Interest in children and ability to relate to them; compatible to their needs.

Respect for confidentiality.

Education - no limitations, but enjoyment of math.

Flexible, friendly, patient and optimistic.

Sense of humor.

Dress - appropriate and comfortable for participation in child's activities.

Orientation and Training: Two hours basic training to the school and its volunteer program. Twelve hours training in tutoring mathematics.

Responsible to: School chairman and principal.

*Project MOTIVATE
Des Moines Area Community College
Ankeny, Iowa*

SAMPLE JOB DESCRIPTION

Type of Work: Media Assistant

Purpose: To assist in the enrichment of the students' experiences and classroom activities through the use of multi media.

Place of Work: In school classroom, auditorium, office, or designated place, as assigned by principal or staff representative.

Hours: Regularly or on call, as needed.

Duration of Job: For time scheduled, as needed by teacher.

Duties: Under the direction and guidance of the teacher, librarian, or media director:

1. Assist in the preparation of media materials for use in classroom and in tutoring sessions.
2. Operate media equipment for presentations of audio and visual materials.
3. Teach other volunteers or students how to prepare materials and operate equipment.

Volunteer Qualifications: Good health; agreeable to take required health tests.

Dependable and prompt.

Education - no limitations.

Creativity.

Aptitude for mechanics of machine operation.

Dress - appropriate and comfortable

Orientation and Training: Basic training in operation of equipment and preparation of materials. In-service training to improve skills.

Responsible to: School chairman and principal.

*Project MOTIVATE
Des Moines Area Community College
Ankeny, Iowa*

-192-1193

ORIENTATION AND TRAINING

At the time of the volunteer's interview, it should be emphasized that to be an effective aide to the school staff and to children, orientation and training must be required, to allow one to serve. During the interview the following fundamentals should be presented, to emphasize the importance of their role in the school volunteer program.

ATTITUDE - Volunteers must take to their job an attitude of open-mindedness. You must be willing to be trained and welcome supervision. Accept the rules and don't criticize what you don't understand, for there may be a good reason.

DEPENDABILITY - The dependability of a volunteer is essential if he is to be of real service to the agency. If you cannot be at the agency at an appointed time, it is the volunteer's responsibility to notify the proper person.

COMMUNICATION - As a volunteer you not only serve the needs of an agency in an important way, but you also provide a vital link between the agency and the community as a friend, as a supporter and as an interpreter.

RESPONSIBILITY - As a volunteer you are assuming certain responsibilities similar to that of a professional. You have agreed to serve without pay but with the same high standard as staff works. All confidential matters must be kept confidential.

Orientation is different from training, in that it is the process of giving an intelligent and descriptive understanding of the philosophy of education, an interpretation of school policies and the components of the school in which the volunteer has agreed to serve.

Job induction is the first step of in-service training and should include introduction by the school chairman or staff liaison person of volunteer to the staff member for their specific assignment, and to other volunteers who are "on the job". Answering questions about source of guidance and supervision is important. The outline in this chapter for Orientation and Training for School Volunteers suggests components of the orientation session, in-service training and on-the-job training.

Orientation of principals includes the program's history, philosophy, goals and objectives, and then they are questioned if their librarians, teachers, and students need assistance, or special enrichment programs. The same type of session may be presented to teachers. School staff may contribute many excellent suggestions for utilization of volunteers' services. Attitudes of both staff and volunteers need to be examined to establish a harmonious relationship. If the volunteers are invited to faculty meetings, specifically in their area of interest, such as math or science, beneficial results will develop.

In Volunteer ABC's, A Handbook for Educational Volunteer Programs, published by the Office of Education, Volunteers in Education, it is stated -

"There is ready recognition of the need to train volunteers, but often little is done to 'train' staff members to understand, accept, and assist volunteers. Many of the negative or questioning attitudes and concerns of educational staff can be modified by advanced planning and thoughtful orientation which directly involves them. Also the frequent turn-over in school staff especially in inner-city areas indicates a need for continuous orientation to the benefits of volunteer service. It is important to note that such orientation should involve all staff members, both professional and non-professional, administrative, teaching and clerical. Such an orientation program might be given during 'released time' periods.

COMPONENTS OF A PROGRAM

"An orientation program that is developed with staff members can interpret the need for and worth of volunteer service. Basically, an orientation program might clarify three aspects of a volunteer program:

1. The nature and scope of volunteer services
2. The special contribution and value of volunteer services
3. The efficacy of the team concept including volunteers as well as staff.

Specific topics to be considered might include:

1. Philosophy and goals of volunteer service
2. Procedures and mechanics of a volunteer program
3. Responsibilities of staff to the volunteer program
4. Performance of specific services by volunteers
5. Effective utilization of volunteer services by staff
6. Problems of volunteer participation
7. Methods of solving the problems
8. Interpersonal relationships.

"An alternative format for staff orientation is a joint volunteer-staff orientation. Benefits other than common understanding of goals and practices can be realized through this type of joint activity. It can, for example, lead to healthy volunteer-staff relationships. Joint sessions can also reduce the time and energy expended on orientation programs. This format will also enable the volunteer to become acquainted with the staff member(s) with whom she will be working."

The Boston School Volunteer Program¹ has found that failure can be guaranteed in a program by forcing unwilling principals or teachers to accept volunteers. They recommend that if there is only one volunteer in a school, all teachers in that school should be required to take at least one hour of orientation so everyone will understand the role of the volunteer and the purpose of a school volunteer program.

¹ "Educational Manpower", Olivero and Buffie, Indiana University Press, pp. 123 & 124.

ORIENTATION AND TRAINING FOR SCHOOL VOLUNTEERS

GUIDELINES FOR SCHOOL ORIENTATION PROGRAM

- I. Welcome and Introductions
 - A. Volunteer Personnel
 - B. School Personnel
- II. Philosophy of Volunteering
- III. History, Purpose and Objectives of the Program and Its Role in the Community
- IV. Administration
 - A. Channels of Communications

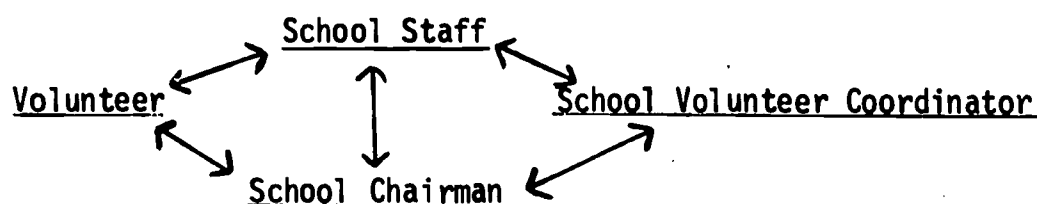

B. School Policies

1. Dress and Behavior
2. Health Exam Requirements
3. Liability (Insurance)
4. Fund Raising
5. Discipline
6. Releasing Children to Adults
7. Visitors
8. Students leaving classroom
9. Teacher leaving classroom
10. Books sent home
11. Notes and letters sent home
12. Lost and found
13. Emergency calls during school hours and use of phone
14. Use of custodial services
15. Working in child's classroom
16. Parking
17. Teachers' lounge

V. Volunteers

A. Responsibilities

1. Conviction that what you are doing is right
2. Interest in helping a child
3. Dependability
4. Loyalty
5. Willingness to learn and accept supervision

6. Confidentiality

- a. staff
- b. child
- c. school records

7. Absences (procedures to follow)
8. Checking in and out (time sheet)
9. Reading posted bulletins and newsletters
10. Acceptance of all school rules

B. Rights

1. To be treated as a co-worker
2. To have a job description, for duty to be performed
3. Suitable assignment - with consideration for personal preference, experience, and education
4. To know as much about the program and the school as possible
5. To be trained for a specific job, when training is necessary
6. Continuing training on the job
7. Sound guidance and direction
8. Opportunity to be heard
9. Recognition

VI. Additional related topics

- A. Establishing relationship with the child
- B. Understanding of the learning process
- C. Understanding of the community in which the volunteer is involved, if other than her own

VII. Tour of plant

- A. Classroom observations or demonstration
- B. Facilities and regulations of the building
 1. Sign in and out location
 2. Traffic patterns, entrances, exits
 3. Fire drill routes and locations
 4. Lavatory locations (children and adults)
 5. Supply and book rooms
 6. Location of audio visual equipment
 7. Work rooms
 8. Eating facilities
 9. Parking facilities
 10. Smoking facilities and/or teachers' lounge

GUIDELINES FOR IN-SERVICE TRAINING

- I. General characteristics of children to be served
- II. Specialized training in particular area of work, such as reading, math, science, library or in operation of audio visual equipment
- III. Policies of school in relation to program
 - A. Homework
 - B. Schedules of staff and students
 - C. Confidentiality
- IV. Classroom visitation
- V. Resources for helping child
- VI. New techniques and resources
- VII. For leadership and progressively more complex duties
- VIII. Discussion period
- IX. On-going informal consultation with staff members and other volunteers

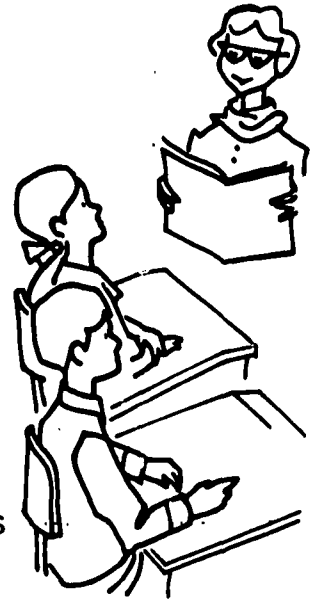

ON-THE-JOB TRAINING

Actual training in the particular area to which a volunteer is assigned. This training would be done by the staff person with whom the volunteer is placed. For classroom and tutorial situations, the teacher should discuss with the newly trained volunteer:

- I. The educational level of the class
- II. Special problems within the class
- III. Individual and family background of students to be served
- IV. Class routine and procedures
- V. Helpful techniques and materials to use in reinforcing the child's learning and attitudes
- VI. Understanding the capabilities and inabilities of the child

*Project MOTIVATE
Des Moines Area Community College
Ankeny, Iowa*

For GENERAL BIBLIOGRAPHY consult the book Your Volunteer Program by Mary T. Swanson, available from Des Moines Area Community College.

MEDIA BIBLIOGRAPHY

Application and Operation of Audio-visual Equipment in Education

Pula, Fred John
John Wiley & Sons, Inc.
New York, 1968

Audiovisual Materials: Their Nature and Use

Wittech, Arno Walter
Schuller, Charles Francis
Harper & Row
New York, 1967

A.V. Instructional Materials Manual

Brown, James W., Lewis, Richard B.
McGraw-Hill Company
New York, 1969

A.V. Instructions Media and Methods

Brown, James W., Lewis, Richard B., Harclerod, Fred F.
McGraw-Hill Company
New York, 1969

Bridges for Ideas Booklets

University of Texas

Creating with Paper

Johnson, Pauline
University of Washington Press
Seattle, 1967

Display and Exhibit Handbook

Heyett, William
Reinhold Publishing Corp.
New York, 1967

An Empty Spoon

Decker, Sunny
Harper & Row
New York, 1969

Film Making for Children

Pflaum/Standard
38 W. 5th Street
Dayton, Ohio 45402 \$3.95

Film Making in Schools

Lowndes, Douglas
Watson Guptill
London, 1968

Fundamentals of Teaching with Audiovisual Technology

Erickson, Carlton, W.H.
The Macmillan Company
New York, 1965

A History of Instructional Technology

Saettler, Paul
McGraw-Hill
New York, 1968

Instructional Design

Kemp, Jerrold E.
Belmont, California
Fearon Publishers, 1971

Manual of Audio-Visual Techniques

De Kreffer, R.E. & Cochran, Lee W.
Prentice Hall, Inc.
New Jersey, 1962

Operating Audio Visual Equipment

Eboch, Sidney C. & Cochran, George W.
Chandler Publishing Company
San Francisco, 1968

Planning and Producing Audiovisual Materials

Kemp, Jerrold E.
Chandler Publishing Company
San Francisco, 1968

Preparation of Inexpensive Teaching Materials

Morlan, John E.
Chandler Publishing Company
San Francisco, 1963

Preparing Instructional Objectives

Mager, Robert F.
Fearon, 1962
Palo Alto

The Teacher and Overhead Projection
A Treasury of Ideas, Uses and Techniques
Schultz, Morton J.
Prentice Hall, Inc., Englewood Cliffs,
New Jersey 07632

Teaching and Media
Gerlach, Vernon S., Ely, Donald P.
Prentice Hall, Inc.
Englewood Cliffs, New Jersey, 1971

Teaching with Technology
Teacher, January 1972, Page 4

Techniques for Producing Visual
Instructional Media
Minor, Ed; Frye, Harvey R.
McGraw-Hill Book Company
New York, 1970

A Treasure Chest of Audio-Visual Aids
The Kalart Company, Inc.
Plainsville, Connecticut 06062

The Use of Photography to Enhance
Learning in the Classroom
Viggiani, James C.
Special Education in Canada
November 1969

SOURCES OF FREE AND INEXPENSIVE MATHEMATICS TEACHING MATERIALS

Applications of Mathematics in the
New Spirit of St. Louis Arch
(pamphlet - 75 cents)
Harrisburg Area Community College
2988 North Second Street
Harrisburg, Pennsylvania 17110

Can I Be A Mathematician?
Pamphlet - General Motors Corp.
General Motors Building
3044 West Grand Boulevard
Detroit, Michigan 48202

Chart on Decimal Equivalents
Greenfield Tap and Die
Greenfield, Massachusetts

Decimal Equivalents of Common
Fractions - Chart
Decimal Equivalents of Fractional
Parts of a Foot - Chart
Smith-Corona Marchant, Inc.
Education & Training Dept.
410 Park Avenue
New York 22, New York

An Excursion in Numbers - Manual
The Duodecimal Soc. of America
20 Carlton Place
Staten Island
New York, New York 10304

Facts for Math Pamphlet
Automobile Manufacturers Assoc.
Educational Services
320 New Center Building
Detroit, Michigan 48202

Home-Math Games - Pamphlet
The Turnpike Press, Inc.
Box 170
Annandale, Virginia 22003

Lists of Publications
National Council of Teachers
of Math
1201 Sixteenth Street, N.W.
Washington, D.C. 20036

Math Tables - Pamphlet
Illinois Tool Works, Inc.
2501 North Keeler Avenue
Chicago, Illinois 60639

Mathematics Chart
Facit-Odhner, Inc.
895 Stanton Road
Burlingame, California

Mathematics of Space Age - brochure
Friden, Inc.
2350 Washington Avenue
San Leandro, California 94577

Mathematics in Action - pamphlet
Institute of Life Insurance
277 Park Avenue
New York, New York 10017

Mathematics Magazine
The American Mathematical Monthly
Mathematical Assoc. of America, Inc.
SUNY at Buffalo
University of Buffalo
Buffalo, New York 14214

Mathematics Serving Man - reprints with
pictures
International Business Machine Company
Department of Information
590 Madison Avenue
New York 22, New York

Mathematical Pie
Mathematical Pie, Ltd.
100 Burman Road
Shirley, Solihull
Warwickshire, England

The Measurement Pinch - reprint
Curtis Publishing Company
The Educational Bureau
Independence Square
Philadelphia 5, Pennsylvania

Men of Modern Mathematics
International Business Machine Company
520 El Camino Road
San Mateo, California 94402

New Directions in Math
Association for Childhood
Education International
3615 Wisconsin Avenue, N.W.
Washington, D.C. 20016

Precision - A Measure of Progress
(history of measurement) pamphlet
General Motors Corporation
Educational Relations Section
Department of Public Relations
Technical Center
Warren, Michigan

Request mathematic publications
Superintendent of Documents
Government Printing Office
Washington, D.C. 20402

School Science and Mathematics
P. O. Box 246
Bloomington, Indiana 47401

Should You Be A Mathematician?
Pamphlet
Career Information Service
New York Life Insurance Company
Box 51, Madison Square Station
New York, New York 10010

Story of Money - pamphlet
Chase Manhattan Bank Money Museum
Rockerfeller Center
1254 Avenue of the Americas at
50th Street
New York, New York

MATHEMATICS BIBLIOGRAPHY

All Kinds of Time
Behn, Harry
Harcourt, Brace and Co.
New York

Arithmetic Can Be Fun
Loaf, Munro
J. B. Lippincott Co.
New York

Arithmetic Problems in Grocery Buying
Tripp, Fern Supermarket
Fern Tripp Publisher

Arithmetic: References and Teaching
Aids
Jean Preston, Assistant Director,
Region VI, IMB, Room 201 Pulliam Hall
Southern Illinois University
Carbondale, Illinois 62901

The Art of Awareness
Bois, J.S.
W.C. Brown Co.
Dubuque, Iowa

Brian Wildsmith's 1, 2, 3's
Brian Wildsmith
Franklin Watts Inc.
575 Lexington Avenue
New York, New York 10022

The Complete Book of Children's Play
Hartley and Goldenson
Thomas Y. Crowell Company

A Concise History of Mathematics
Struik, D.J.
Dover Publications
New York

The Crescent Dictionary of Mathematics
Karush
The Macmillan Co.
866 Third Avenue
New York, New York 10022

Drop in Math
Catterton, G.
Wynne Public Schools
Wynne, Arkansas
(Price app. \$5.00)

Elementary School Mathematics
Banks, J. Houston
Allyn and Bacon Inc.
Boston, Massachusetts

Exploration of Space and
Practical Measurement
Dienes and Golding
Herder and Herder, Inc.
New York
(Price app. \$1.60)

Fantasia Mathematica
Fadiman, C.
Simon and Schuster
New York

Five Little Stories
Strader, W.W.
National Council of Teachers of
Mathematics
1201 16th Street, N.W.
Washington, D.C. 20036

Fun with Mathematics
Meyer, J.S.
Fawcett Publications, Inc.
Greenwich, Connecticut

Giant Golden Book of Mathematics
Exploring the World of Numbers and Space
Adler, Irving
Golden Press, Inc.
New York

Guide for the Mathematics Volunteer
Division of Mathematics
Cleveland City School District
Cleveland, Ohio

Guidelines for the Volunteer Tutor
(pages 14-17)
EPDA Volunteer Coordinators Training
Program
Des Moines Area Community College
2006 Ankeny Boulevard
Ankeny, Iowa 50021

How Big is Big?
Schnoider, Herman and Nina
William R. Scott
New York

How Can I Help Children Learn Mathematics
A Handbook for Tutors
Los Angeles City School Volunteer Program
Office of Urban Affairs
450 North Grand Avenue
Room G-372
Los Angeles, California 90012

How to Use the Overhead Projector
in Mathematics
Krusik, Stephen and Kaufman, Irwin
National Council of Teachers of
Mathematics

How to Use Your Bulletin Board
Johnson, D.A. and Olander, C.E.
National Council of Teachers
of Mathematics

Introducing Children to Math
Lawson, Ernestine M.
The Instructor Publications, Inc.
Dansville, New York 14437

Invitation to Mathematics
Exploring Mathematics on Your Own
Johnson, D.A. and Glenn, W.H.
Webster Publishing Co.

Involving Low-Achievers in Mathematics
Shoemaker, T.E.
Jefferson County School System
Lakewood, Colorado

The Key to Helpful Mathematics
Bulletin Boards
Hayes School Publishing Co. Inc.
321 Pennwood Avenue
Wilksburg, Pennsylvania 15221

Learning and Teaching Arithmetic
Banks, J. Houston
Allyn and Bacon Inc.
Boston, Massachusetts

Let's Find Out About Addition
Whitney, D.
Franklin Watts Inc.
New York

Lines and Shapes
Russell, S.
Henry Z. Walch, Inc.
New York

The Low Achiever in Mathematics
Woodby, L.G.
U.S. Government Printing Office
Washington, D.C.

L.A.M.P. (Low Achievers Motivational
Program)
Zimmerman, J.T.
Des Moines Public Schools
Des Moines, Iowa

The Laidlaw Glossary of Arithmetical
Mathematical Terms
Gundlach, Bernard H.
Laidlaw Brothers
River Forest, Illinois

Magic House of Numbers
Adler, I.
Signet Science Library
New York

Mathematics Background for the
Primary Teacher
Merton and May
John Colburn Assoc. Inc.
Wilmette, Illinois

Mathematics for the Elementary
School Teacher
Nichols and Swain
Holt, Rinehart & Winston Inc.
383 Madison Avenue
New York, New York 10017

Mathematical Diversions
Hunter and Madachy, A.H. and J.S.
D. Van Nostrand Company, Inc.
New York

The Mathematical Magpie
Fadiman, C.
Simon and Schuster
New York

Mathematical Nuts
Jones, S.I.
S.I. Jones Co.
Nashville, Tennessee

Mathematical Recreations
Kraitchik, M.
Dover Publications
New York

Mathematical Recreations and Essays
Rouse Ball, W.W.
The Macmillan Co.
New York

Mathematical Snapshots
Steinhaus, H.
Oxford University Press
New York

Mathematical Wrinkles
Jones, S.I.
S.I. Jones Co.
Nashville, Tennessee

Math Workshop Enrichment Activities
Encyclopedia Britannica Press
425 N. Michigan Avenue
Chicago, Illinois 60611

Modern Math for Modern Parents
Cwirka, C.S.
J. Weston Walch
Box 1075
Portland, Maine 04104

Numbers
Allen, Robert
Platt and Munk
New York

Numbers of Things
Oxenbury, Helen
Franklin Watts Inc.
New York

Number Patterns Exploring Mathematics
on Your Own
Glenn, W.H. and Johnson, D.A.
Webster Publishing Company

One Step, Two
Zolotow, Charlotte
Lothrop, Lee and Shepherd Co.
New York

1,2,3, A Book to See
Wondriska, William
Pantheon
New York

1,2,3,4,5
Gregor, Arthur
J.B. Lippincott Co.
New York

1,2,3 to the Zoo
Carl, Eric
World Publishing Co.
New York

Paper Folding for the Mathematics Class
Johnson, D.
National Council of Teaching Mathematics
Washington, D.C.

Personalizing Mathematics
Mobile Math Lab
Long Beach Unified School District
Long Beach, California

Plus: Handbook
Platts, Mary E.
Educational Service Inc.
Stevensville, Michigan

Polyominoes
Golomb, S.W.
Charles Scribner's Sons
New York

Probability and Chance - Exploring
Math on Your Own
Johnson, D.A.
McGraw-Hill Book Co.

101 Puzzles in Thought and Logic
Wylie, C.R., Jr.
Dover Publications, Inc.
New York

Recipes for Creative Activities
Board of Education
Prince George's County
Upper Marlboro, Maryland

Seeing Through Mathematics
C. Van Engel
Foresman and Company
Fairlawn, New Jersey

The Sesame Book of Numbers
Little, Brown, and Company
Boston, Massachusetts

Sets, Sentences, and Operations
Exploring Mathematics on Your Own
Johnson, D.A. and Glenn, W.H.
McGraw-Hill Book Co.

The Space Childs Mother Goose
Winsor, F. and M. Parry
Simon and Schuster
New York

Tachnist-0-Filmstrips -
Learning Through Seeing, Inc.
Sunland, California

Take a Number
O'Neill, Mary
Doubleday and Co.
New York

Teacher's Handbook of Answers and
Background Data for Enrichment
Mathematics Worksheets for
Elementary Schools - Grades 3-4
San Diego City Schools
San Diego, California

Teaching the New Mathematics
Crescimbeni, Joseph
Parker Publishing Co.
West Nyack, New York

Treasury of Classroom Arithmetic
Activities
Joseph Crescimbeni
Parker Publishing Company
West Nyack, New York

Tutoring Tips for Volunteers
Office of Volunteer Services
Mississippi State University
Room 102 YMCA

The Volunteer and Modern Math
South Huntington School Volunteer
Program
Silas Wood School
Huntington Station, New York

What is an Inch?
Kline, M.
Oxford University Press
New York

The Winning Touch
Educational Fun Games

The World of Measurement - Exploring
Math on Your Own
Johnson, D.A. and Glenn, W.H.
McGraw-Hill Book Co.

The World of Statistics - Exploring
Mathematics on Your Own
Johnson, D.A. and Glenn, W.H.
McGraw-Hill Book Co.

Who-What-Why-How Math Quiz
Cwirka, C.S.
J. Weston Walch
Box 1075
Portland, Maine 04104

Workbook for Teachers
Houghton Mifflin
2nd Park Street
Boston, Massachusetts 02107

Understanding Math Today
Los Angeles City School Volunteer Program
Office of Urban Affairs
450 North Grand Avenue
Room G-372
Los Angeles, California

Volunteer Handbook
San Francisco Education Auxiliary
135 Van Ness Street
San Francisco, California

GAMES AND GAME BOOKS

Amusements in Mathematics
Dudeney, H.E.
Dover Publications, Inc.
New York
(Price app. \$1.50)

Arithmetic Can Be Fun
Ed-U-Cards - Addition and Subtraction

Arithmetic Can Be Fun
Ed-U-Cards - Multiplication and Division

Arithmetic Games
Dumas, E.
Fearon Publishers, Inc.

Arithmetic Games and Activities
Wagner, Hosier, and Gilloley
Teachers Publications Corporation
23 Leroy Avenue
Darian, Connecticut 06820

Arithmetic Games for Volunteer
Tutors
Goldszer, Beatrice
School Volunteer Association of
Pittsburgh
Pittsburgh, Pennsylvania

Building Arithmetic Skills with Games
Pamphlet
Corle, Clyde G.
The Instructor
Dansville, New York

Educational Games and Activities
Wagner, Hosier, Blackman, Gilloley
Teachers Publications Corporation
23 Leroy Avenue
Darian, Connecticut 06820

Equation-Type Flash Cards
Instructional Aids, Inc.
Owatonna, Minnesota

Games and Activities for Early
Childhood Education
Wagner, Gilloley, Roth, Cosinger
Teachers Publications Corporation
23 Leroy Avenue
Darian, Connecticut 06820

Mathematical Puzzles for Beginners
and Enthusiasts
Mott-Smith G.
Dover Publications, Inc.
New York

Mathematical Puzzles of Sam Loyd
Gardner, M. (ed.)
Dover Publications Inc.
New York

Mathematics Games for all Grades
May, Lola J.
Teachers Publications Corporation

2nd Miscellany of Puzzles
Barr, S.
The Macmillan Company
New York

Skill Games for Mathematics
Corle, Clyde G.
The Instructor
Dansville, New York

Smarty Arithmetic Bingo Game
Central Bindery Company

Suggested Games and Learning Activities
Los Angeles City School Volunteer Program
Office of Urban Affairs
450 North Grand Avenue
Room G-372
Los Angeles, California 90012

Sum Fun and Adding and Subtracting
Ringo Game
Educational Fun Games

SCIENCE BIBLIOGRAPHY

Aerospace Education and Model Rocketry
An Educator's Guide for Grades Four
through Ten
Daniel F. Saltrick and Alfred M. Kubota
Estes Industries
Box 227
Penrose, Colorado 81240

All Around You
Bendick, Jeane
McGraw-Hill Book Co., Inc.
New York, 1951

All Ready for Winter
Adelson, Leone
David McKay Co., Inc.
1952

The Book of Magnets
Freeman, Mae
Four Winds Press
New York, 1968

The Clean Brook
Bartlett, Margaret P.
Thomas Y. Crowell Co.
New York, 1960

The Complete Book of Children's Play
Hartley and Goldenson
Thomas Y. Crowell Company
New York

The Curious Naturalist
datebook available in both standard
and undated versions
Massachusetts Audubon Society
Lincoln, Massachusetts 01773
\$2.50 each plus 25¢ postage

Discovering Science Series
Piltz, Blough, Roche
Charles E. Merrill Publishing Co.
1300 Alum Creek Drive
Columbus, Ohio 43216

Earthworms
Hogner, Dorothy C.
T. Y. Crowell Company

Ecology: The Circle of Life
Hungerford, Harold
Childrens Press

Educational Games and Activities
Wagner, Hosier, Blackman, Gilloley
Teachers Publications Corporation
23 Leroy Avenue
Darian, Connecticut 06820

Everyday Trees
Allen, Gertrude
Houghton Mifflin Co.
Boston, 1968

Everyday Weather and How It Works
Schneider, Herman
McGraw-Hill Book Company
330 W. 42nd Street
New York, New York 10036

Experiments in Science
Nelson, Buler
T. Y. Crowell Company

Exploring Nature with Your Child
Dorothy Edward Shuttlesworth
Greyston Press
Hawthorne Books
100 Sixth Avenue
New York, New York

First Book of Electricity
Epstein, Sam
Franklin Watts
845 Third Avenue
New York, New York 10022

Fun With Science
Freeman, Mae B.
Random House, Inc.
201 E. 50th
New York, New York 10022

Games & Activities for Early Childhood
Wagner, Gilloley, Roth, Cosinger
Teachers Publications Corporation

The Good Rain
Goudey, Alice
Aladdin Books
New York, 1950

Hear Your Heart
Showers, Paul
Thomas Y. Crowell Co.
New York, 1968

High Sounds, Low Sounds
Branley Franklyn
Thomas Y. Crowell Co.
New York, 1967

How A Seed Grows
Jordan, Helene
T. Y. Crowell Company

How and Why Series
Wonder Books - New York
Division of Grosset and Dunlap Inc.

1. Beginning Science
Jerome J. Notkin and
Sidney Gulkin
2. Chemistry - Martin L. Keen
3. Electricity - Jerome Notkin and
Sidney Gulkin
4. Light and Color
Harold Highland
5. Magnets and Magnetism
Martin L. Keen
6. Science Experiments
Martin L. Keen
7. Time - Gene Liberty

How Does It Work?
Richard M. Koff
Doubleday & Company, Inc.
501 Franklin Avenue
Garden City, New York 11530

How to Make a Cloud
Jeanne Bendick
Stepping Stone Book
Parents Magazine Press

How You Talk
Showers, Paul
Thomas Y. Crowell Co.
New York, 1967

I Like Winter
Lenski, Lois
Oxford University Press
New York, 1950

It's Nesting Time
Gans, Roma
Thomas Y. Crowell Co.
New York, 1964

Learning About Science Through Games
Goodrich, W.
Stackpole Books
Cameron & Kelker Streets
Harrisburg, Pennsylvania 17105

Let's Find Out
Schneider, Herman
Addison-Wesley Publishing Co., Inc.
Reading, Massachusetts 01867

Let's Find Out About Magnets
Knight, David C.
F. Watts, Inc.
New York, 1967

Let's Go Outdoors
Huntington, Harriet E.
Doubleday & Co., Inc.
Garden City, New York, 1939

The Listening Walk
Showers, Paul
T. Y. Crowell Company

Look at Your Eyes
Showers, Paul
Thomas Y. Crowell Co.
New York, 1962

Magnets and How to Use Them
Pine, Tillie S.
McGraw-Hill Book Co., Inc.
New York, 1958

Noise Pollution & Air Pollution
Lavaroni & O'Donnell
Addison Wesley

North, South, East and West
Branley, Franklyn
Thomas Y. Crowell Co.
New York, 1966

Now It's Fall
Lenski, Lois
Oxford University Press
1948

Once There Was a Tree
Busch, Phyllis S.
World Publishing Co.
Cleveland, 1968

Plants
Waller, Leslie
Grosset and Dunlap, 1967

Prove It!
Wylar, Gerald A.
Harcourt Brace Jovanovich

Readers Digest Science Reader
Blue Book
F. M. Branley
Readers Digest Services Inc.

Readers Digest Science Reader
Green Book
F. M. Branley
Readers Digest Services Inc.

Readers Digest Science Reader
Orange Book
F. M. Branley
Readers Digest Services Inc.

Readers Digest Science Reader
Red Book
F. M. Branley
Readers Digest Services Inc.

Recipes for Creative Activities
Board of Education
Prince George's County
Upper Marlboro, Maryland

Rusty Rings A Bell
Brandley, Franklyn
T. Y. Crowell Company

700 Science Experiments for Everyone
Compiled by UNESCO
Doubleday & Company, Inc.

Science Games and Activities
Wagner, Dueda, Finsand, Mork
Teachers Publications Corporation

Science in the Elementary School
What Research Says to the Teachers Series
Craig, G.S.
National Education Association

Science in Your Own Backyard
Cooper, Elizabeth
Harcourt Brace Jovanovich

Seeds by Wind and Water
Jordan, Helene
Thomas Y. Crowell Co.
New York, 1962

Simple Machines and How They Work
Sharp, Elizabeth
Random House
201 E. 50th Street
New York, New York 10022

Simple Machines and How We Use Them
Pine, Tillie S.
McGraw-Hill Book Co., Inc.
New York

Snow is Falling
Branley, Franklyn
Thomas Y. Crowell Co.
New York, 1963

Sound--An Experiment Book
Baer, Marion
Holiday House Inc.
18 E. 56th Street
New York, New York 10022

A Sourcebook for the Biological Sciences
Morholt, Evelyn
Harcourt Brace Jovanovich

A Sourcebook for Elementary Science
Hone, Elizabeth
Harcourt Brace Jovanovich

Sparrows Don't Drop Candy Wrappers
(Ecology)
Margaret Gabel
Dodd Mead

Spring Is Here
Lenski, Lois
Oxford University Press
New York, 1945

Stepping into Science (Activities)
Podendorf, Illa
Childrens Press

The Sun, Our Nearest Star
Branley, Franklyn
Thomas Y. Crowell Co.
New York, 1961

A Tree is a Plant
Bulla, Clyde Robert
Thomas Y. Crowell
New York, 1960

The True Book of Air Around Us
Friskey, Margaret
Childrens Press
Chicago, 1953

True Book of Animals of the Sea and Shore
Podendorf, Illa
Childrens Press
Chicago, 1956

True Book of Birds We Know
Friskey, Margaret
Childrens Press
Chicago, 1954

True Book of Conservation
Gates, Richard
Childrens Press
Chicago

The True Book of Health
Haynes, Olive
Childrens Press
Chicago, 1954

True Book of Insects
Podendorf, Illa
Childrens Press
Chicago, 1954

True Book of Pets
Podendorf, Illa
Childrens Press
Chicago, 1954

True Book of Reptiles
Ballard, Lois
Childrens Press
Chicago, 1957

The True Book of Science Experiments
Podendorf, Illa
Childrens Press

The True Book of Sounds We Hear
Podendorf, Illa
Childrens Press

True Book of Space
Podendorf, Illa
Childrens Press
Chicago, 1959

True Book of Trees
Podendorf, Illa
Childrens Press
Chicago, 1954

The True Book of Weather Experiments
Podendorf, Illa
Childrens Press
Chicago, 1961

Your Skin and Mine
Showers, Paul
Thomas Y. Crowell Co.
New York, 1965

True Book of Weeds and Wildflowers
Podendorf, Illa
Childrens Press
Chicago, 1955

Water Pollution
Lavaroni, O'Donnell, & Lindberg
Addison Wesley

SCIENCE FILMS:

What Is a Fish?
Darby, Gene
Benefio Press
Chicago, 1958

A variety of films for both
elementary and secondary level,
available on loan free from
Northwestern Bell Telephone Company

What is Electricity?
Corcoran, Eileen, and Pavka, John R.
Frank E. Richards Publishing Co.
324 First Street
Box 370
Liverpool, New York 13088

What's Inside of Me?
Nim, H.S.
Wm. Morrow and Company

What Makes A Shadow
Clyde R. Bulla
T.Y. Crowell Company

What Makes Day and Night
Branley, Franklyn
Thomas Y. Crowell Co.
New York, 1961

Your Body and How It Works
Lauber, Patricia
Random House
New York, 1962

FREE AND INEXPENSIVE SCIENCE MATERIALS

Chemistry at Work
Pamphlet
Goodyear Tire and Rubber Co.
Akron, Ohio

How the Telephone Works
Pamphlet
American Telephone and Telegraph Co.
195 Broadway
New York, New York

National Referral Center for Science
and Technology
Pamphlet
Library of Congress
Washington, D.C. 20540

"School Science and Mathematics"
School Science and Mathematics
P. O. Box 246
Bloomington, Indiana 47401

"Ten Men and the Telephone"
Bell Telephone Laboratories
463 West Street
New York, New York 10014

HANDICAPPED BIBLIOGRAPHY

Adapting Materials for Educating
Blind Children with Sighted Children
University of the State of New York,
Albany

State University of New York, State
Education Department, Bureau for
Handicapped Children, Washington
Avenue, Albany, New York 12203

Alpha Chi Omega Toy Book
Alpha Chi Omega Fraternity
Indianapolis, Indiana

Arithmetic Curriculum for the
Mentally Handicapped
Sisters of St. Francis of Assisi
Cardinal Stritch College

Arithmetic Guidelines for Special Education
Alaska State Department of Education

Arithmetic: References and
Teaching Aids
(Bibliography of materials for
teaching math to handicapped)
Jean Preston - Assistant Director
Region VI, IMC
Room 201 Pulliam Hall
Southern Illinois University
Carbondale, Illinois 62901

Arithmetic Skills for Living and Learning
Guide for Teachers of Children with
Retarded Mental Athletic Store
Neuber, M.A.
State College of Pennsylvania

Aspects of Arithmetic Learning
in Mental Retardates
Metzger, Rolland
Dixon State School, Illinois

At Work and Play, Television in the
Lives of the Deaf and the Hard of
Hearing
Cross, B.G.
Alexander Graham Bell Assn. for Deaf,
Washington, D.C.

Audio-Visual Education for the Retarded
Cotter, Katharine C.
Elementary School Journal
May 1963

Audio-Visual Material on Mental
Retardation
National Association for Retarded
Children, 420 Lexington Avenue,
New York, New York

Audio Visual Materials
Robinault, Isabel P., Comp.
United Cerebral Palsy Assoc.
New York, New York

Audio Visual Techniques in Teaching
Foreign Languages
Huebener, Theodore
New York - University Press

Captioned Films for the Deaf
Gough, John A.
The Council for Exceptional Children
Washington, D.C.

Creative Ideas for Teaching
Exceptional Children
Wedemeyer, Avaril; Cejka, Joyce
Love Publishing Company
Denver, Colorado 80222

A Curriculum in Arithmetic for the
Educable Mentally Retarded
McEwan, Christine and others
Maine State Department of Education

Development and Evaluation of Auto-
Instructional Programs in Arithmetic
for the Educable Mentally Handicapped
Higgins, Conwell; Rusch, Reuben R.
Albany Public Schools
New York

Education for the Slow Learners
Johnson, G. Orville
Prentice Hall, Inc.
Englewood Cliffs, New Jersey

Educational Aids for Visually
Handicapped
American Printing House for the Blind
Louisville, Kentucky
Office of Education (DHEW), Washington, D.C.
Bureau of Education for the Handicapped

The Educational Media Complex; Symposium
on Research and Utilization of Educational
Media for Teaching the Deaf
(3rd, Lincoln, Nebraska, April 10-12, 1967)
Nebraska University Teachers College, Lincoln,
Department of Educational Administration
Office of Education (DHEW), Washington, D.C.,
Captioned Films for the Deaf

Enrichment--Classroom Challenge
Gibbons, Hazel L.
Ohio State Department of Education
Columbus, Ohio

An Evaluation of High School Mathematics
Programmed Texts When Used With Deaf
Students
Bornstein, Harry
Gallaudet College, Washington, D.C.
Office of Education (DHEW), Washington, D.C.

The Exceptional Child
Barbe, Walter B.
The Center for Applied Research
in Education
Washington, D.C.

Exceptional Children in the Schools
Dunn, Lloyd N.
Holt, Rinehart & Winston, Inc.
New York

A Feasibility Study to Investigate the
Instrumentation, Establishment, and
Operation of a Learning Laboratory
for Hard-of-Hearing Children
Stapp, Robert E.
Nebraska University, Lincoln,
Extension Division
Office of Education (DHEW), Washington, D.C.

Fun Phonic Jungles Coloring Books
Book 1 - sounds "r", "l", "s"
Book 2 - sounds "th", "sh", "f", "k"
Word Making Productions, Inc.

Following from:

Fallett Educational Corp.
1010 West Washington Blvd.
Chicago, Illinois 60607

1. The Silly Listening Book
(Environmental sounds)
2. An Ear is to Hear
(Discrimination of environmental
sounds)
3. Bendemolena
(Introduces vocal play and makes
transition from listening to
environmental sounds to listening
to speech sounds)
4. The Hungry Thing
(Auditory discrimination of rhyming
words)
5. Ding-dong, Bing-bong
(Auditory discrimination of similar
sounding word pairs.)

Games and Other Activities for
Developing Language Skills
Gotkin, Lassar G.
New York University, New York,
Institute for Developmental Studies

Guidelines for the Tutor in Teaching
English as a Second Language
Los Angeles City Schools
Division of Instructional Planning and
Services
Instructional Planning Branch
Publication N.E.C.-339 1970

Handbook for Counselors
Camp Sunnyside
401 N.E. 66th Avenue
Des Moines, Iowa

Introduction to Exceptional Children
Baker, Harry J.
The Macmillan Company

Listening Ears
and
Listening Ears Card Set
Stanwix House, Inc.
3020 Charters
Pittsburgh, Pennsylvania 15204

The Media-Curriculum Specialist in Special Education: Resources Notebook. Report of the Media-Curriculum Institute-Burke, D.A. (East Lansing, Michigan, June 16-20, 1969)
Michigan State University, East Lansing
Michigan State Department of Education, Lansing

The Mentally Retarded Child and Educational Films
Abraham, Willard
Coronet Films, 65 East South Water Street, Chicago, Illinois 60601

A Multi-Media Approach in the Classroom for the Deaf
Schmitt, Robert J.
New Mexico Foundation, Inc.
American Annals of the Deaf, Volume 3, 1966

National Center on Educational Media and Materials for the Handicapped: Policies and Procedures
Office of Education (DHEW), Washington, D.C.
Bureau of Education for the Handicapped

A New Outlook for Education of Handicapped Children
By Edwin W. Martin
taken from magazine
American Education, April 1970, p. 7-10
United States Department of Health, Education, and Welfare
Office of Education
Washington, D.C.

Picture-Sound Association in Deaf Children
Doehring, Donald G.
Canadian Department of National Health and Welfare

Playing Cards as Instructional Aids
Vergason, Glenn A. and others

Programed Instruction and the Academically Gifted: The Effects of Creativity and Teacher Behavior on Programed Instruction with Younger Learners
Gotkin, Lassar G.; Massa, Nicholas
Columbia University, New York, New York, Institute for Educational Technology
Carnegie Corporation of New York, New York
New York State Education Department, Albany

Rhymes for Fingers and Flannel Boards
Webster Division
McGraw-Hill Book Co.
Manchester Road
Manchester, Missouri 63011

Science Curriculum for the Mentally Handicapped
Sisters of St. Francis of Assisi
Cardinal Stritch College

Science for the Blind
Science for the Blind, Bala Cynwyd, Pennsylvania

A Selected Bibliography on Teaching Machines and Programed Instruction
Lazar, Alfred L.; Gelhart, Robert P.
Colorado State College, Greeley, Rocky Mountain SEIMC

Self Teaching in the Development of Speechreading in Deaf Children
Neyhus, Arthur I.
Institute for Language Disorders
Evanston, Illinois

Suggested Basic Materials for Slow Learning Children
Allen, Amy A.; Cross, Jacque L.
Ohio Department of Education
Columbus

Snoopy Snake and Other Stories
(31 entertaining sound oriented
stories of 25 consonant sound)
Word Making Productions, Inc.
60 West 400 South
Salt Lake City, Utah 84101

Some Suggested Sources of Equipment
and Teacher Aids for Partially
Seeing Children
National Society for the Prevention
of Blindness, New York, New York

Speech Handicapped School Children
Johnson, Wendell
Harper & Row
New York

Symposium on Research and Utilization of
Educational Media for Teaching the Deaf:
Individualizing Instruction for the Deaf
Student.
Midwest Regional Media Center for the Deaf,
Lincoln, Nebraska; Nebraska University, Lincoln,
Teachers College, Office of Education (DHEW),
Washington, D.C., Captioned Films for the Deaf
Branch

Systems Approach in Deaf Education,
Symposium on Research and Utilization
of Educational Media for Teaching the
Deaf (Lincoln, Nebraska, April 4-6, 1966)
Stepp, Robert E.
Nebraska Univ., Lincoln, Teachers Coll.

Teaching Aids and Toys for
Handicapped Children
Dorward, Barbara
National Education Association
1201 16th Street, N.W.
Washington, D.C. 20036

Teaching Aids for Blind and Visually
Limited Children
Dorward, Barbara; Barraga, Natalie
American Foundation for the Blind
15 West 16th Street
New York, New York 10011

Teaching Arithmetic to Deaf Children
Education Series, Book Two
O'Neill, Veronica
The Volta Bureau

Teaching Arithmetic to Mentally
Retarded Children
Thomas, J.K.
T.S. Denison & Company

Teaching Arithmetic to Slow Learners
and Retarded
Feingold, Abraham
The John Day Company

Toys and Games for Educationally
Handicapped Children
Buist, Charlotte A.; Schulman, Jerome L.
Charles C. Thomas, Publisher, 301-327
East Lawrence Avenue, Springfield,
Illinois 62703

Treating Reading Difficulties
The Role of the Principal, Teacher,
Specialist, and Administrator
U.S. Department of Health, Education,
and Welfare
Office of Education

The Use of Overhead Projection in
Classrooms for the Mentally Retarded
Meyen, Edward L. and others
Iowa University, Iowa City;
Special Education Curriculum
Development Center, Iowa City
Iowa State Department of Public
Instruction, Des Moines;
Office of Education (DHEW),
Washington, D.C.

A source to write for information
regarding special educational facilities
and programs for children with handicaps:

Closer Look
Box 1492
Washington, D.C. 20013

TAPES

Auditory - Familiar Sounds
50 familiar sounds used in
conjunction with 50 flash
cards - teaches sound skills
and identification

Auditory Training
Gross and instrumental sounds,
teach matching and discrimination

Both of above order from:

Developmental Learning Materials
3505 N. Ashland Avenue
Chicago, Illinois 60657

Creativity and Bulletin #28
Torrance, E. Paul
National Education Assoc.
Dept. of Classroom Teachers and
American Educational Research Assoc.
Washington, D.C.

Gifted Children in the Classroom
Torrance, E. Paul
The Macmillan Company
New York

Guidelines for Motivating Illiterates
and Promoting Literacy
Literacy Council of Montgomery County
Maryland, Inc.

Individual Differences in the Classroom
Thomas, Murray and Shirley
David McKay Company, Inc.
New York

New Approaches to the Education
of the Gifted
Woolcock, Cyril
Silver Burdett Co.
Chicago, Illinois

RECORDS

Listening with Mr. Bunny Big Ears
(Six record albums to develop
communication skills-listening,
speaking, reading)
Stanwix House, Inc.

Listening Time - Grades 1-3
Narration of 33 1/3 rpm stories and
poems - encourage listening habits
3 albums
Webster Division
McGraw-Hill Book Co.
Manchester, Road
Manchester, Missouri 63011

Sounds Around Us
Scott Foresman Co.
Chicago, Illinois

Let's Listen (The Muffin records)
Children's Music Center
5373 W. Pico Blvd.
Los Angeles, California

ADDRESSES OF PUBLISHERS

Addison-Wesley Publishing Co., Inc.
Reading,
Massachusetts 01867

Benefic Press
10300 W. Roosevelt Road
Westchester, Illinois 60153

Chandler Publishing Co.
Division of Intext Educational
Publishers
College Division
124 Spear Street
San Francisco, California 94105

Childrens Press
Division of Regensteiner Publishing
1224 W. Van Buren Street
Chicago, Illinois 60607

Thomas Y. Crowell Company
201 Park Avenue South
New York, New York 10003

Doubleday & Co., Inc.
501 Franklin
Garden City, New York 11530

Dover Publications
180 Varick Street
New York, New York 10014

Fearon Publishers
6 Davis Drive
Belmont, California 94002

Four Winds Press
Division of Scholastic Book Service
Scholastic Magazines Inc.
50 West 44th Street
New York, New York 10036

Harcourt Brace Jovanovich, Inc.
757 Third Avenue
New York, New York 10017

Harper and Row
49 East 33rd Street
New York, New York 10016

Holiday House, Inc.
18 E. 56th Street
New York, New York 10022

Houghton Mifflin Co.
2 Park Street
Boston, Massachusetts 02107

Macmillan Company
866 Third Avenue
New York, New York 10022

McGraw-Hill Book Co.
330 W. 42nd Street
New York, New York 10036

David McKay Co.
750 3rd Avenue
New York, New York 10017

Oxford University Press
200 Madison Avenue
New York, New York 10016

Prentice Hall
Englewood Cliffs,
New Jersey 07632

Random House, Inc.
201 E. 50th Street
New York, New York 10022

Readers Digest Services Inc.
Educational Division
Pleasantville, New York 10570

Van Nostrand Reinhold Co.
Division of Litton Educational
Publishers
450 W. 33rd Street
New York, New York 10001

Franklin Watts
845 Third Avenue
New York, New York 10022

John Wiley & Sons, Inc.
605 Third Avenue
New York, New York 10016

World Publishing Co.
110 E. 59th Street
New York, New York 10022

**des moines area
community college**

2006 ANKENY BLVD., ANKENY, IOWA 50021

PHONE 964-0651

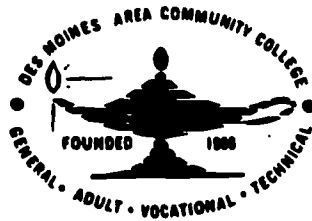

Paul Lowery, Superintendent

Board of Directors

Rolland E. Grefe, President

Harry Bloomquist

Ross C. Cramlet

Cecil R. Galvin

Walter Hatzal

Max W. Kreeger

David S. Longnecker

William C. Price

Harold F. Wellin

207